

WHAT'S NEW



SOLIDWORKS 2018



Contents

- Legal Notices 11

- 1 Welcome to SOLIDWORKS 2018 14
 - Top Enhancements 14
 - For More Information 16

- 2 User Interface 17
 - Auto-Rotate View on Sketch Edit 17
 - Folder Icons in the FeatureManager Design Tree 18
 - Logging into SOLIDWORKS 19
 - Measure Tool Enhancements 20
 - Mouse Gestures Enhancements  21
 - Rollback Bar and Freeze Bar User Interface Enhancements 22
 - Scaling of Entities on High-resolution Monitors 22
 - Show File Names and Descriptions in Design Library 23
 - Task Pane Changes 23
 - Touch-based Interactions  24
 - Custom Numeric Keypad 24
 - Magnified Selection 25
 - Touch Mode 25
 - Welcome Dialog Box  26
 - Home Tab 26
 - Recent Tab 28
 - Learn Tab 28
 - Alerts Tab 29



- 3 SOLIDWORKS Fundamentals 30
 - Adobe Illustrator Creative Cloud Files 30
 - Application Programming Interface 30
 - Default Templates for New Documents 31
 - Include or Exclude Suppressed Components in Pack and Go 32
 - Rebuild Tools 32
 - Selecting Over Geometry 33
 - Support for 3D Printing Models Containing Surface Bodies and Graphics Bodies 34



- 4 Installation 36
 - Installing SOLIDWORKS CAM 36
 - Installing SOLIDWORKS Manage Professional 36





Upgrading SOLIDWORKS PCB Services	37
5 Administration.....	38
Controlling Dismissed Messages	38
Displaying Document Open Time in Windows Explorer	39
Specifying a Template for General Tables.....	40
Synchronizing Settings and Options Across Multiple Machines.....	40
Task Scheduler Supports Additional File Formats	41
6 Assemblies.....	43
Asset Publisher and Magnetic Mates Enhancements.....	43
Changing the Transparency of an Assembly or Multibody Part.....	44
Check Entity Enhancements.....	44
Mates.....	45
Perpendicular Mates.....	45
Temporarily Hiding Faces When Selecting Mates.....	45
Misaligned Mates.....	46
Allowing Misaligned Concentric Mates.....	46
Assemblies System Option for Misaligned Mates.....	48
Document Properties - Mates.....	48
Motion Study Menu Enhancements.....	48
Pattern Enhancements.....	49
Including Material and Visual Properties in a Mirrored Part	49
Linear Pattern Enhancements.....	49
Performance Evaluation Enhancements.....	51
Assembly Open Progress Indicator.....	51
Assembly Visualization Enhancements	52
Performance Evaluation Tool Enhancements.....	52
Smart Explode Lines.....	54
Creating and Dissolving Smart Explode Lines.....	54
Smart Explode Lines PropertyManager.....	56
SpeedPak	58
Setting a Rebuild on Save Mark on SpeedPak Configurations.....	58
Updating SpeedPak Configurations Automatically.....	58
Treehouse Enhancements.....	59
Display Files in a List View.....	59
Hiding Suppressed Documents.....	60
Print Options.....	61
User Interface.....	61
7 SOLIDWORKS CAM.....	62
Documentation.....	62
Rebranding.....	62
Setting Subroutines for Parts.....	62
Setting the Toolpath Output Folder.....	63
Technology Database.....	64













User Interface Improvements.....	64
CommandManager.....	64
Display Colors.....	64
Save Operation Plan.....	64
8 CircuitWorks.....	65
Ability to Recognize SOLIDWORKS Features in CircuitWorks.....	65
Editing Hole Features in the CircuitWorks Export Wizard.....	65
Exporting SOLIDWORKS Features Using the CircuitWorks Export Wizard.....	66
Building Model as a Part in CircuitWorks.....	67
Usability Improvements.....	68
Controlling CircuitWorks User Options from an Administrator Location Using Windows User	
Permissions.....	68
Editing Reference Designators of Multiple Components.....	68
Setting Up Administrator Rights.....	69
9 SOLIDWORKS Composer.....	70
SOLIDWORKS Composer.....	70
Label Orientation and Label Position for Measurements.....	70
Padding for Measurements.....	70
Support of Favorite Context.....	70
Support of Pro/E Creo 3.0.....	71
Write Outlines.....	71
SOLIDWORKS Composer Sync.....	71
Support of Favorite Context.....	71
Support of Pro/E Creo 3.0.....	71
Write Outlines.....	71
SOLIDWORKS Composer Player.....	72
Label Orientation and Label Position for Measurements.....	72
Padding for Measurements.....	72
10 SOLIDWORKS Costing.....	73
Calculating the Cost of Custom Operations for Selected Materials.....	73
Costing Template Enhancements.....	74
Limited-Access Multibody and Assembly Templates.....	74
Machining and Sheet Metal Template Enhancements.....	75
Evaluating the Cost of Assembly Operations.....	75
Organizing and Saving Costing Data Locally.....	76
11 DimXpert.....	78
3D PMI Compare for DimXpert Annotations Is Enhanced.....	78
Automatic Generation of DimXpert Annotations for Fastener Assemblies.....	78
Customizable General Tolerances for DimXpert.....	80
Customizing the General Tolerance File.....	81
Using a Customized General Tolerance File.....	82
Inserting a General Tolerance Table.....	83





Displaying Component-level DimXpert Annotations in Assemblies	83
General Profile Tolerance	84
Inserting a General Profile Tolerance in a Note	84
Editing a Geometric Profile Tolerance	85
Patterned Datums	85
12 Detailing and Drawings	89
Annotations	89
Auto Hatching in Section Views	89
Custom Property Improvement	89
Movable Datum Target	89
New Draft Symbols	92
New Geometric Tolerance Options	92
Dimensions	93
Hole Callouts Supported in Advanced Hole Tool	93
Trailing Zeroes	94
Drawing Views	97
Applying Layers and Colors to Hatches	97
Blocks in Break Views	98
Broken-Out Section Views	99
Inserting a 3D View in a Drawing	101
Output	101
Bookmarks in PDF Output	101
Tables	101
All Uppercase Characters	101
Revision Table Driven By SOLIDWORKS PDM	102
13 eDrawings	103
3D Views	103
Decals in eDrawings Files	103
Setting Options and Passwords for eDrawings Files	104
STEP Files in eDrawings Files	104
Attaching STEP Files to eDrawings Files	104
Opening STEP Files in eDrawings	105
User Interface Enhancements	106
Zooming In and Out	107
14 SOLIDWORKS Electrical	108
Connection Point Display	108
Global Project Drawing Styles	108
Global Wire Mark Display	109
Multilevel Terminals	109
Natural Sort Option for Marks	109
Other Enhancements for SOLIDWORKS Electrical	110
Project Level Attribute Styles	110
SOLIDWORKS Electrical and SOLIDWORKS Routing Integration	111

Symbol Editor	111
Terminal Strips	111
Unused Wires	112
User Data for Manufacturer Parts	112
Wire Numbering Group	112
15 SOLIDWORKS Flow Simulation	113
Color Bar	113
Component Explorer	114
Free Surface	114
Full Template	114
Noise Prediction	114
Plot Callouts	114
Sector Periodicity	115
16 SOLIDWORKS 3D Interconnect	116
Additional File Formats Supported 	116
JT Files	116
STEP, IGES, and ACIS Files	116
Additional Information Supported for Reading from Third-Party Native CAD Files 	117
Assembly Cut Features	117
Custom Properties	117
Material Properties	118
Unconsumed Sketches and Curves	118
17 SOLIDWORKS Inspection	119
SOLIDWORKS Inspection Add-in	119
SOLIDWORKS Part and Assembly Support	119
SOLIDWORKS Inspection Standalone	121
2D File Support	121
3D File Support	122
Balloon Sequences	122
CMM Data Management Import	123
Create and Place Sub-Balloons	123
Customizable Balloon Numbering	124
Customizable Tolerance Type	124
Explode Note	125
Export to CAMS XML and Verisurf	125
Export to QualityXpert Improvements	125
ExtractionXpert	125
Full Specification	125
Ignore Basic Dimensions	126
Improved Optical Character Recognition	126
Improved User Interface	126
Merge Characteristics	126

Net-Inspect Options	127
Predefining Balloon Appearances	127
Publish Reports with Document Snapshots	127
Revision Management	128
Sampling	128
Smart Extract	128
Undo and Redo	129
18 SOLIDWORKS MBD	130
3D PDF Templates	130
3D PMI Compare Versions	132
3D Views Slideshow	133
Bill of Materials	133
Configuration-specific Properties in 3D PDF	134
Inserting Configuration-specific Properties in a Text Field	134
Inserting Configuration-specific Properties in a Table	134
Import PMI	134
Insert a Note in a 3D PDF Field	134
MBD Templates	135
19 Model Display	136
Offloaded Rendering 	136
Using Single Offloaded Rendering	136
Using Scheduled Offloaded Rendering	137
20 Parts and Features	138
Advanced Hole	138
Customizing Advanced Hole Callouts	138
Defining Hole Elements with Baseline Dimensions	140
Block Editing of Linked Custom Properties in Derived Parts	140
Cosmetic Threads Improvements	140
Creating a Bounding Box 	140
Deduplicate Tool Improvements	142
Extracting Geometry from a Corrupted Solid Body 	142
Feature Freeze Bar Works with All Folders	142
Hole Wizard Options to Match Size or Preserve Settings	143
Mesh BREP Bodies	144
Workflows for Working with Mesh BREP Bodies	146
Options for Importing Mesh Files	147
Converting Solid, Surface or Graphics Bodies to Mesh	148
Selection Filters for Mesh Bodies	149
Creating a Surface From Mesh Feature	150
Selecting Facets Using Paint Select	154
List of Features Supporting Mesh BREP Bodies	154

Enhancements to Importing Mesh Files as Graphics Bodies	157
More Control Over Custom Properties	157
Adding an @ Sign Before Quotation Marks	158
Unlinking and Relinking Properties to a Parent Part	158
21 SOLIDWORKS Manage	160
SOLIDWORKS Manage Overview	160
Project Management	160
Process Management	161
Item Management	161
Dashboards and Reports	161
22 SOLIDWORKS PCB	162
Adding Hardware to SOLIDWORKS CAD	162
Component Movement in 3D CAD	162
CST Integration	163
IPC-Compliant Footprint Wizard	163
DB Link	163
PCB Services HTTPS Support	164
Positioning Embedded Components	164
Symbol Wizard	164
Variant Collaboration	165
23 SOLIDWORKS PDM	166
Automated Drawing PDF Creation in SOLIDWORKS PDM Standard 	166
Configuring the Convert Task (For SOLIDWORKS PDM Standard only)	167
Converting a SOLIDWORKS Drawing File to PDF	167
Data Card Editor Undo 	168
Design Branching and Merging 	168
Branching Settings	169
Merging Settings	176
Detailed Warning Messages 	183
Enhanced Assignment of Explicit Folder Permission	184
Enhanced File Version Upgrade Tool	184
Upgrade Tool Behavior for Checked out Files	184
File Version Upgrade Summary	185
Monitoring the Upgrade Process	185
Notifying Users About the Upgrade Process	186
Enhanced Permission Control	186
Quality Enhancements in SOLIDWORKS PDM	186
Revision Table Integration 	187
Configuring Revision Table Integration	187
Configuring the Revision Table Node	188
Defining Variable Mapping	189

Revision Table Dialog Box.....	189
Setting Dynamic Variable Values in Copy Tree.....	190
SOLIDWORKS PDM Application Programming Interface.....	191
SOLIDWORKS PDM Support for Non-SOLIDWORKS CAD File References 	192
24 SOLIDWORKS Plastics.....	193
Clamp Force in Machine Opening Direction.....	193
Density Result at End of PACK Analysis.....	193
Exclude Area from Clamp Force Calculation.....	194
Export Deformed Geometry.....	194
Mesh Enhancements.....	194
Shrinkage Percentage in Warp Measure.....	195
Temperature Criteria for Short Shots.....	196
25 Routing.....	197
Flattening Enhancements.....	197
General Routing Enhancements.....	198
Routing Library Manager Enhancements.....	198
General Routing Library Manager Enhancements.....	198
SOLIDWORKS Electrical and Routing User Interface Integration.....	199
26 Sheet Metal.....	200
Creating Normal Cuts 	200
Tab and Slot 	201
Creating a Tab and Slot.....	202
Three Bend Corner Reliefs 	204
Corner Relief Display.....	204
Creating Suitcase Corner Reliefs.....	205
27 SOLIDWORKS Simulation.....	207
Topology Study 	207
Material Mass Plot.....	209
Topology Optimization of a Plate.....	210
Allow for Dismissal of Warning Messages 	214
Create a Results Plot from Imported Data 	214
Displacement Control for Nonlinear Contact 	215
Email Notification for Completed Analyses 	215
Factor of Safety Plot for Nonlinear Static Studies 	215
Import Simulation Study Features into Assemblies 	215
Improved Pin Connector 	216

Mesh Refinement for Stress Singularities 	217
Sensor for Simulation Mass Properties 	217
28 Sketching	218
Controlling the Tangency Direction	218
Creating Mirrored Entities in 3D Sketch	219
Enabling and Disabling Automatic Solve and Undo for Sketches	219
Fixing the Rotation of Sketch Pattern Instances	220
Instance Limit Removed for Circular Sketch Patterns	220
Mirroring Entities Using Reference Planes and Planar Faces	221
Pen, Touch, and Gesture-based Sketching 	221
Smart Dimension on the Context Toolbar	221
Controlling Dimensions with the Context Toolbar	222
29 SOLIDWORKS Toolbox	223
Descriptions and Comments No Longer Disappear	223
Hexalobular Hardware	223
Importing and Exporting Hole Wizard Data	224
Selecting PEM Inserts	225
Toolbox User Interface and Workflow	225
30 SOLIDWORKS Utilities	226
SOLIDWORKS Design Checker Misaligned Mates	226
31 SOLIDWORKS Visualize	227
3DConnexion Spacemouse Support	227
Area Light Enhancements	229
Cloud Library Enhancements	229
Decal Improvements	229
Help Menu Improvements	231
Import all SOLIDWORKS Cameras, Custom Views, and Lights	231
Interactivity Performance Improvements	233
Remove Camera Post-Processing from Backplates	235
Stereoscopic and 360° Cameras for Virtual Reality	235
Application Examples	236
360 Lens	236
Stereoscopy	237
Updated User Interface	239
32 Weldments	243
Customizing Description for Bounding Box Properties 	243
Linking a Cut List Folder to a Cut List Property 	243

Legal Notices

© 1995-2017, Dassault Systemes SolidWorks Corporation, a Dassault Systèmes SE company, 175 Wyman Street, Waltham, Mass. 02451 USA. All Rights Reserved.

The information and the software discussed in this document are subject to change without notice and are not commitments by Dassault Systemes SolidWorks Corporation (DS SolidWorks).

No material may be reproduced or transmitted in any form or by any means, electronically or manually, for any purpose without the express written permission of DS SolidWorks.

The software discussed in this document is furnished under a license and may be used or copied only in accordance with the terms of the license. All warranties given by DS SolidWorks as to the software and documentation are set forth in the license agreement, and nothing stated in, or implied by, this document or its contents shall be considered or deemed a modification or amendment of any terms, including warranties, in the license agreement.

Patent Notices

SOLIDWORKS® 3D mechanical CAD and/or Simulation software is protected by U.S. Patents 6,611,725; 6,844,877; 6,898,560; 6,906,712; 7,079,990; 7,477,262; 7,558,705; 7,571,079; 7,590,497; 7,643,027; 7,672,822; 7,688,318; 7,694,238; 7,853,940; 8,305,376; 8,581,902; 8,817,028; 8,910,078; 9,129,083; 9,153,072; 9,262,863; 9,465,894; 9,646,412 and foreign patents, (e.g., EP 1,116,190 B1 and JP 3,517,643).

eDrawings® software is protected by U.S. Patent 7,184,044; U.S. Patent 7,502,027; and Canadian Patent 2,318,706.

U.S. and foreign patents pending.

Trademarks and Product Names for SOLIDWORKS Products and Services

SOLIDWORKS, 3D ContentCentral, 3D PartStream.NET, eDrawings, and the eDrawings logo are registered trademarks and FeatureManager is a jointly owned registered trademark of DS SolidWorks.

CircuitWorks, FloXpress, PhotoView 360, and TolAnalyst are trademarks of DS SolidWorks.

FeatureWorks is a registered trademark of HCL Technologies Ltd.

SOLIDWORKS 2018, SOLIDWORKS Standard, SOLIDWORKS Professional, SOLIDWORKS Premium, SOLIDWORKS PDM Professional, SOLIDWORKS PDM Standard, SOLIDWORKS Simulation Standard, SOLIDWORKS Simulation Professional, SOLIDWORKS Simulation Premium, SOLIDWORKS Flow Simulation, eDrawings Viewer, eDrawings Professional, SOLIDWORKS Sustainability, SOLIDWORKS Plastics, SOLIDWORKS Electrical Schematic Standard, SOLIDWORKS Electrical Schematic Professional, SOLIDWORKS Electrical 3D, SOLIDWORKS Electrical Professional, CircuitWorks, SOLIDWORKS Composer, SOLIDWORKS Inspection, SOLIDWORKS MBD, SOLIDWORKS PCB powered by Altium, SOLIDWORKS PCB Connector powered by Altium, and SOLIDWORKS Visualization are product names of DS SolidWorks.

Other brand or product names are trademarks or registered trademarks of their respective holders.

COMMERCIAL COMPUTER SOFTWARE - PROPRIETARY

The Software is a “commercial item” as that term is defined at 48 C.F.R. 2.101 (OCT 1995), consisting of “commercial computer software” and “commercial software documentation” as such terms are used in 48 C.F.R. 12.212 (SEPT 1995) and is provided to the U.S. Government (a) for acquisition by or on behalf of civilian agencies, consistent with the policy set forth in 48 C.F.R. 12.212; or (b) for acquisition by or on behalf of units of the Department of Defense, consistent with the policies set forth in 48 C.F.R. 227.7202-1 (JUN 1995) and 227.7202-4 (JUN 1995)

In the event that you receive a request from any agency of the U.S. Government to provide Software with rights beyond those set forth above, you will notify DS SolidWorks of the scope of the request and DS SolidWorks will have five (5) business days to, in its sole discretion, accept or reject such request. Contractor/Manufacturer: Dassault Systemes SolidWorks Corporation, 175 Wyman Street, Waltham, Massachusetts 02451 USA.

Copyright Notices for SOLIDWORKS Standard, Premium, Professional, and Education Products

Portions of this software © 1986-2017 Siemens Product Lifecycle Management Software Inc. All rights reserved.

This work contains the following software owned by Siemens Industry Software Limited:

D-Cubed® 2D DCM © 2017. Siemens Industry Software Limited. All Rights Reserved.

D-Cubed® 3D DCM © 2017. Siemens Industry Software Limited. All Rights Reserved.

D-Cubed® PGM © 2017. Siemens Industry Software Limited. All Rights Reserved.

D-Cubed® CDM © 2017. Siemens Industry Software Limited. All Rights Reserved.

D-Cubed® AEM © 2017. Siemens Industry Software Limited. All Rights Reserved.

Portions of this software © 1998-2016 HCL Technologies Ltd.

Portions of this software incorporate PhysX™ by NVIDIA 2006-2010.

Portions of this software © 2001-2017 Luxology, LLC. All rights reserved, patents pending.

Portions of this software © 2007-2016 DriveWorks Ltd.

© 2011, Microsoft Corporation. All rights reserved.

Includes Adobe® PDF Library technology

Copyright 1984-2016 Adobe Systems Inc. and its licensors. All rights reserved. Protected by U.S. Patents 5,929,866; 5,943,063; 6,289,364; 6,563,502; 6,639,593; 6,754,382; Patents Pending.

Adobe, the Adobe logo, Acrobat, the Adobe PDF logo, Distiller and Reader are registered trademarks or trademarks of Adobe Systems Inc. in the U.S. and other countries.

For more DS SolidWorks copyright information, see **Help > About SOLIDWORKS**.

Copyright Notices for SOLIDWORKS Simulation Products

Portions of this software © 2008 Solversoft Corporation.

PCGLSS © 1992-2017 Computational Applications and System Integration, Inc. All rights reserved.

Copyright Notices for SOLIDWORKS PDM Professional Product

Outside In® Viewer Technology, © 1992-2012 Oracle

© 2011, Microsoft Corporation. All rights reserved.

Copyright Notices for eDrawings Products

Portions of this software © 2000-2014 Tech Soft 3D.

Portions of this software © 1995-1998 Jean-Loup Gailly and Mark Adler.

Portions of this software © 1998-2001 3Dconnexion.

Portions of this software © 1998-2014 Open Design Alliance. All rights reserved.

Portions of this software © 1995-2012 Spatial Corporation.

The eDrawings® for Windows® software is based in part on the work of the Independent JPEG Group.

Portions of eDrawings® for iPad® copyright © 1996-1999 Silicon Graphics Systems, Inc.

Portions of eDrawings® for iPad® copyright © 2003 – 2005 Apple Computer Inc.

Copyright Notices for SOLIDWORKS PCB Products

Portions of this software © 2017 Altium Limited.

1

Welcome to SOLIDWORKS 2018

This chapter includes the following topics:

- **Top Enhancements**
- **For More Information**

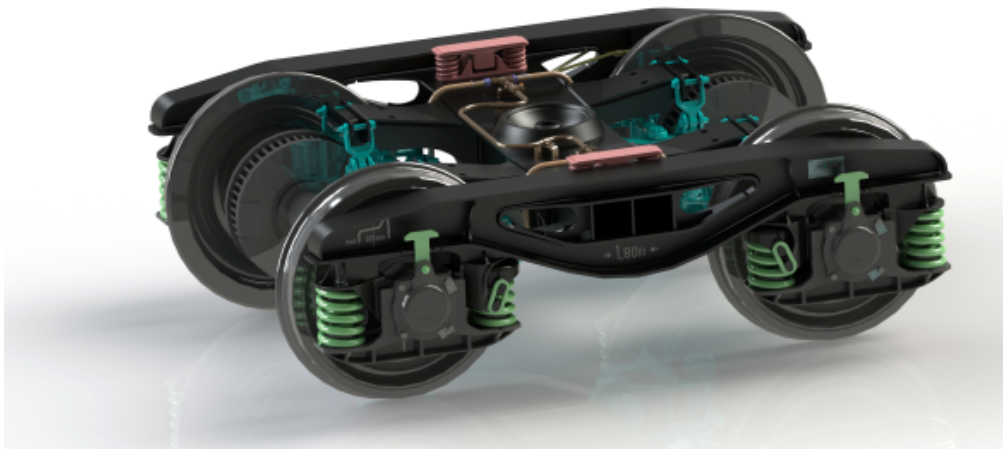

Image courtesy of S.C. ASTRA RAIL Industries S.R.L.

SOLIDWORKS® 2018 delivers many enhancements and improvements, most created in direct response to customer requests.

This release provides four new end-to-end process solutions that simplify the interactions between disciplines across product development to improve your business outcomes. Accelerate innovation and grow your business with the following new processes:

- Design to Manufacturing Process. A complete solution to bring your ideas to market.
- Distributed Data Management Process. The right data, at the right time, for the right people.
- Designer to Analyst Process. Analysis tools for every step of the design process.
- Electrical Design and Internet of Things (IOT) Process. Connect your smart devices to your customers.

Top Enhancements

The top enhancements for SOLIDWORKS 2018 provide improvements to existing products and innovative new functionality.

Throughout this guide, look for the  symbol in these areas:

- User Interface**
 - [Mouse Gestures Enhancements](#) on page 21
 - [Touch-based Interactions](#) on page 24
 - [Welcome Dialog Box](#) on page 26

- SOLIDWORKS 3D Interconnect**
 - [Additional File Formats Supported](#) on page 116
 - [Additional Information Supported for Reading from Third-Party Native CAD Files](#) on page 117
 - [STEP, IGES, and ACIS Files](#) on page 116

- Model Display**
 - [Offloaded Rendering](#) on page 136

- Parts and Features**
 - [Creating a Bounding Box](#) on page 140
 - [Extracting Geometry from a Corrupted Solid Body](#) on page 142

- Sheet Metal**
 - [Creating Normal Cuts](#) on page 200
 - [Tab and Slot](#) on page 201
 - [Three Bend Corner Reliefs](#) on page 204

- Sketching**
 - [Creating Mirrored Entities in 3D Sketch](#) on page 219
 - [Pen, Touch, and Gesture-based Sketching](#) on page 221

- SOLIDWORKS PDM**
 - [Automated Drawing PDF Creation in SOLIDWORKS PDM Standard](#) on page 166
 - [Data Card Editor Undo](#) on page 168
 - [Design Branching and Merging](#) on page 168
 - [Detailed Warning Messages](#) on page 183
 - [Revision Table Integration](#) on page 187
 - [SOLIDWORKS PDM Support for Non-SOLIDWORKS CAD File References](#) on page 192

- SOLIDWORKS Simulation**
 - [Mesh Refinement for Stress Singularities](#) on page 217
 - [Displacement Control for Nonlinear Contact](#) on page 215
 - [Email Notification for Completed Analyses](#) on page 215
 - [Factor of Safety Plot for Nonlinear Static Studies](#) on page 215
 - [Topology Study](#) on page 207
 - [Improved Pin Connector](#) on page 216
 - [Import Simulation Study Features into Assemblies](#) on page 215
 - [Sensor for Simulation Mass Properties](#) on page 217

- Weldments**
 - [Customizing Description for Bounding Box Properties](#) on page 243
 - [Linking a Cut List Folder to a Cut List Property](#) on page 243

- [More Control Over Custom Properties](#) on page 157

All features are available in SOLIDWORKS Standard, SOLIDWORKS Professional, and SOLIDWORKS Premium unless otherwise noted.

For More Information

Use the following resources to learn about SOLIDWORKS:

What's New in PDF and HTML This guide is available in PDF and HTML formats. Click:

- [Help > What's New > PDF](#)
- [Help > What's New > HTML](#)

Interactive What's New

In SOLIDWORKS, click the  symbol to display the section of this manual that describes an enhancement. The symbol appears next to new menu items and the titles of new and changed PropertyManagers.

To enable Interactive What's New, click **Help > What's New > Interactive**.

What's New Examples

What's New Examples are updated at every major release to provide examples of how to use most top enhancements in the release.

To open What's New Examples click **Help > What's New > What's New Examples**.

Sample files

To open sample files for this book, go to
`system_dir:\Users\Public\Public Documents\SOLIDWORKS\SOLIDWORKS 2018\samples\whatsnew\chapter_name\file_name.`

For example, `C:\Users\Public\Public Documents\SOLIDWORKS\SOLIDWORKS 2018\samples\whatsnew\sketching\Block.sldprt.`

Online Help

Contains complete coverage of our products, including details about the user interface, samples, and examples.

Release Notes

Provides information about late changes to our products, including changes to the *What's New* book, online help, and other documentation.

2

User Interface

This chapter includes the following topics:

- **Auto-Rotate View on Sketch Edit**
- **Folder Icons in the FeatureManager Design Tree**
- **Logging into SOLIDWORKS**
- **Measure Tool Enhancements**
- **Mouse Gestures Enhancements**
- **Rollback Bar and Freeze Bar User Interface Enhancements**
- **Scaling of Entities on High-resolution Monitors**
- **Show File Names and Descriptions in Design Library**
- **Task Pane Changes**
- **Touch-based Interactions**
- **Welcome Dialog Box**

Auto-Rotate View on Sketch Edit

The system option, **Auto-rotate view normal to sketch plane on sketch creation**, has been renamed. It is now available when you edit an existing sketch, as well as when you create a new one.

In **Options > System Options > Sketch**, the option is renamed.

New Name	Auto-rotate view normal to sketch plane on sketch creation and sketch edit
Previous Name	Auto-rotate view normal to sketch plane on sketch creation

The view rotation behavior is now consistent, regardless of how you open the sketch. If the option is selected, the following behavior occurs:

- When you open a new or existing sketch, the view rotates to be normal to the sketch plane.
- When you exit a sketch:
 - If you keep your changes, the view remains normal to the sketch plane. For example,

click  in the Confirmation Corner or **Insert > Exit Sketch**.







- If you discard your changes, the view reverts to the orientation it was before you opened the sketch. For example, click  in Confirmation Corner or **Edit > Exit Sketch without Saving Changes**.

Folder Icons in the FeatureManager Design Tree

The folder icons in the FeatureManager design tree indicate the state of items in the folders.



Assemblies

In assemblies, the icons indicate if the folder contains shown, hidden, or suppressed items, or various combinations.

Icon	Shown	Hidden	Suppressed
	X		
		X	
			X
	X	X	
		X	X
	X		X
	X	X	X

Parts

In parts, the icons indicate if the folder contains unsuppressed or suppressed items, or both.

Icon	Unsuppressed	Suppressed
	X	
		X
	X	X





Logging into SOLIDWORKS

SOLIDWORKS provides a login feature. You use the same SOLIDWORKS ID to access the Customer Portal, MySolidWorks, and the SOLIDWORKS Forums.

You can use the Login dialog box, but you can continue to start SOLIDWORKS as you currently do.

Benefits to logging in with the SOLIDWORKS ID are:

- Hyperlinks to web content within the SOLIDWORKS software will automatically log you into SOLIDWORKS websites, such as:

	MySolidWorks
	SOLIDWORKS Forum
	Customer Portal
	Get Support

- You can synchronize your system settings automatically across multiple computers while logged in. To synchronize settings, click **Tools > Options > Synchronize Settings**.

When you log in, customization and system options (excluding file locations) are synchronized by default.

You can synchronize the following settings:

- File locations listed in **Tools > Options** and Toolbox/Hole Wizard.
- Customizations including toolbar layouts, menu customizations, mouse gestures, and keyboard shortcuts.

To log into the SOLIDWORKS software:

1. In the SOLIDWORKS title bar, click the **Login** icon .
2. In **Email**, enter your SOLIDWORKS ID.
The SOLIDWORKS ID can be your email address.
3. In **Password**, enter your password.
4. Click **Log in**.

The Login icon changes color to indicate that you are logged in.



You remain logged in until you click the **Login** icon  and click **Log Out**. Closing SOLIDWORKS does not log you out.

Measure Tool Enhancements

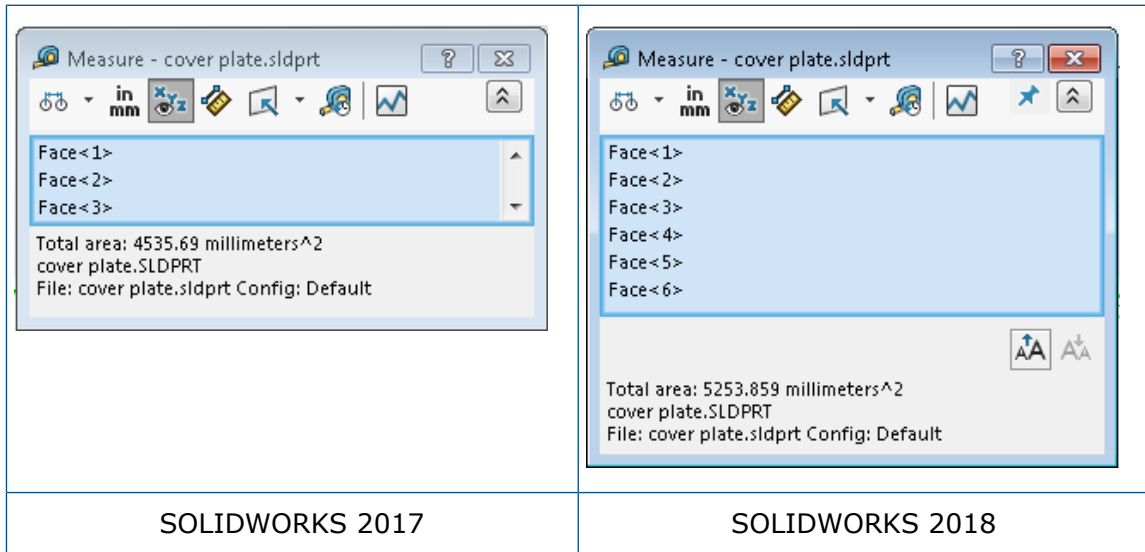

The **Measure**  tool supports the following additional features:

- Input box. The input box that lists selections now includes six items.



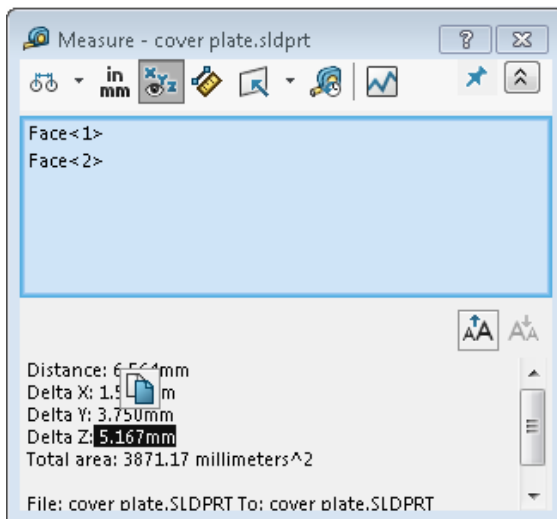

- Quick Copy. When you hover over a numeric value, the numeric value gets highlighted in the dialog box and **Copy**  is displayed. Click  to copy the value to the clipboard. You can paste the value at the required location.



- Font Size. You can adjust the font size of the text in the Measure dialog box. Click  to increase the font size. Click  to decrease the font size.

You cannot decrease the font size below the default size.

- Pin. Click  to pin the Measure dialog box to the graphics area. Click  to close the dialog box.

Click  to unpin the Measure dialog box. Press **Esc** to close the dialog box only if the dialog box is unpinned.

Mouse Gestures Enhancements











Mouse gestures are easier to customize.



You can set the number of mouse gestures to 2, 3, 4, 8, or 12 gestures. If you set the number to 2 gestures, you can orient them vertically or horizontally.

To set the number of mouse gestures, click **Tools > Customize > Mouse Gestures**. From the drop-down list, select the desired number of mouse gestures.

You can also customize the mouse gesture assignments through a visual drag-and-drop user interface. Drag tools from the list of commands to any of the mouse gestures guides. If you drag a tool to an empty position, the tool is added to the gesture guide. If you drag a tool to an occupied position, it replaces the tool on the gesture guide. If you **Ctrl** + drag a tool from one gesture guide position to another, it is copied to the second position. You can copy a tool within one gesture guide, as well as across gesture guides.

Icons are added for the following tools:

Icon	Tool
	Shortcut Bar
	Escape
	Expand/ Collapse Tree
	Collapse all Items
	Exit Sketch without Saving Changes
	Repeat Last Command
	Browse Open Documents
	Browse Recent Folders
	Browse Recent Documents
	Pack and Go

Icon	Tool
	Hide All Types
	Edit Linear Pattern
	Edit Circular Pattern

The following options have changed:

- The four columns showing mouse gesture assignments for Part, Assembly, Drawing, and Sketch are removed. They are replaced by the Mouse Gesture Guide window.
- Show only commands with mouse gestures assigned are removed.
- Print List is changed to Print Gesture Guides.

Rollback Bar and Freeze Bar User Interface Enhancements

Enhancements:

- Less precision is required to select the bars.
- The color of the bars is changed to match the current SOLIDWORKS theme.
- Scaling the bars is improved on high-resolution monitors.

Scaling of Entities on High-resolution Monitors

Entities such as 3D arrows and sketch relations scale well on high-resolution monitors. These entities scale properly according to the screen size, resolution, and display setting. Improved scaling increases the visibility of these entities and makes it easier to work on high-resolution monitors.

Enhancements include:

- The bitmap size increases based on the display scaling.
- The size of the entities in the graphics area increases proportionately according to the scaling factor.
- Scaling of selection changes based on the resolution or DPI setting of the screen.
- 3D arrows in the graphic area scale well on high-resolution monitors. You can easily grab and drag them on a touch screen using your fingers or stylus.

Show File Names and Descriptions in Design Library

You can display file names or descriptions of reusable elements (such as features, sketches, parts, or assemblies) in the lower panel of the Design Library.

To show file names and descriptions:

- Right-click in the lower panel of the Design Library, and click **Show File Name** or **Show Description**.

Previously, commands in this shortcut menu were limited to displaying **Large Icons**, **Small Icons**, or **Adding New Folders**.

Task Pane Changes

Some items from the Task Pane have been moved to the new Welcome dialog box.

The following sections have been removed from the SOLIDWORKS Resources tab in the Task Pane:

- Getting Started
- Community
- Tip of the Day

The following table summarizes the moved items, their new names (if changed), and their new locations within the Welcome dialog box.

Removed Task Pane Item	New Name (if changed)	New Location (Tab in Welcome dialog box)
New Document	New	Home
Open a Document	Open	Home
Tutorials		Learn
Online Training	MySolidWorks Training	Learn
What's New		Home
Introducing SOLIDWORKS		Learn
General Information	Get Support	Home
Customer Portal		Home
User Groups		Home

Removed Task Pane Item	New Name (if changed)	New Location (Tab in Welcome dialog box)
Discussion Forum	SOLIDWORKS Forum	Home
Technical Alerts and News	Technical Alerts	Alerts
Tip of the Day		Home

To access the items in their new location:

In the Task Pane, at the top of the SOLIDWORKS Resources tab, click **Welcome to SOLIDWORKS** .

For more information, see [Welcome Dialog Box](#) on page 26.

Touch-based Interactions

Touch-based interactions are easier and more intuitive.

Custom Numeric Keypad

Touch gestures improve the user experience. The custom numeric keypad for a touch-enabled device makes it faster and easier to input values. The keypad is proportionate to the tool to maximize the visible area.

Previously you used the default operating system keypad that covered a large portion of the screen.

You can turn on touch mode by clicking **View > Touch Mode**. When you touch the numeric input field with your finger or stylus, the custom numeric keypad appears.

The numeric keypad has the following features:

- The keypad gives you more screen space to view and proofread your work.
- You can trigger the numeric keypad for all numeric input fields with spinner controls.
- When you click the **More Options** button, it shows all the parameters associated with the field. For example, the Equation input fields have the following parameters:
 - Global Variables
 - Functions
 - File Properties
 - Units
- Tapping anywhere outside the numeric keypad dismisses the keypad and accepts the new value.

From the taskbar, you can turn on the built-in keypad to enter non-numeric values.

Magnified Selection

The **Magnified Selection** tool is available in touch devices.

If you press the screen for two seconds or more, then drag your finger, the **Magnified Selection** magnifying glass appears. If you press the screen for less than two seconds, then drag your finger, the mouse gesture guide appears.

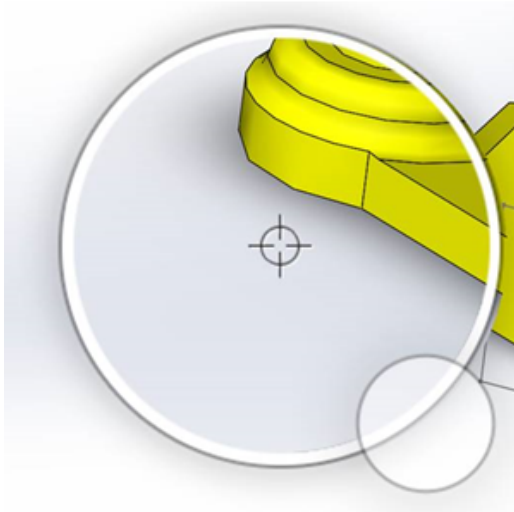





Touch Mode



Touch mode makes the user interface easier to interact with when you use a touch-enabled device. It optimizes the size of on-screen manipulators, context toolbars, breadcrumbs, and selection.

To turn on touch mode, click **View > Touch Mode** .

Touch mode is optimized for left- or right-handed users based on your Windows settings.

When you turn on touch mode, a toolbar of commonly used tools appears on the left or right side of the SOLIDWORKS window, including:

	Escape	Exits the current mode or selection.
	Shortcut (S) Key	Opens the shortcut bar.
	Multi-select	Lets you: <ul style="list-style-type: none"> • Select more than one item at a time. It is equivalent to Ctrl + select with a mouse. • Drag your finger to box select or lasso entities.
	Delete	Deletes the selected item.

	Zoom Up and Zoom Down	Changes the zoom scale for the magnifying glass.
	Lock 3D Rotate	(Sketch mode only) Locks the ability to rotate the model so you do not accidentally rotate the model while sketching.

Welcome Dialog Box

When you open the SOLIDWORKS software, the Welcome dialog box provides a convenient means to open documents, view folders, access SOLIDWORKS resources, and stay updated on SOLIDWORKS news.

You can also click **Welcome to SOLIDWORKS**  (Standard toolbar), **Help > Welcome to SOLIDWORKS**, or **Welcome to SOLIDWORKS** on the SOLIDWORKS Resources  tab in the Task Pane to open the Welcome dialog box.

The Welcome dialog box has tabs for: Home, Recent, Learn, and Alerts.

Some of the content from the Task Pane has moved to the Welcome dialog box to avoid duplication.



Home Tab

The Home tab lets you open new and existing documents, view recent documents and folders, and access SOLIDWORKS resources.

Sections in the Home tab include **New**, **Recent Documents**, **Recent Folders**, and **Resources**.

New

The **New** section includes:

	Part	Opens a new document. The document is based on a template from the Default Templates page of the System Options dialog box.
	Assembly	
	Drawing	
	Advanced	Opens the New SOLIDWORKS Document dialog box, where you can open a new document based on an alternate template.



Open

Opens the Open dialog box, where you can select an existing document to open.

Recent Documents

The **Recent Documents** section includes thumbnails of documents that you have opened recently. Click **View all** to open the Recent tab to see a longer list of recent documents.

Functionality in the **Recent Documents** section is identical to previous versions of the SOLIDWORKS software. The Welcome dialog box replaces the Recent Documents window.

Recent Folders

The **Recent Folders** section includes a list of folders from which you have opened documents recently. Click **View all** to open the Recent tab to see a longer list of recent folders.

When you hover over a folder, you can click  to keep the folder at the top of the **Recent Folders** list until you unpin it.

To access the **Recent Folders** list after you close the Welcome dialog box, click **File > Open Recent > Browse Recent Folders**.

Resources

The **Resources** section includes links to:



What's New



MySolidWorks



SOLIDWORKS Forum



Customer Portal



User Groups



Get Support

Tip of the Day

Shows a new tip each time that you open the Welcome dialog box. Click **<** or **>** to see other tips.

Recent Tab

The Recent tab lets you view a longer list of recent documents and folders.

Sections in the Recent tab include **Documents** and **Folders**.

Documents

The **Documents** section includes thumbnails of documents that you have opened recently.

You can do the following:

- Click a thumbnail to open the document.
- Drag a thumbnail and drop it in the empty graphics area, an open part, assembly, or drawing, or Windows Explorer.
- Hover over a thumbnail to see document information such as full path and last saved date, and click  to see more options and information.
- Right-click a thumbnail and click **Remove**, **Pin**, or **Clear unpinned items**.
- Click **Browse** to open the Open dialog box for the current folder.

If the Welcome dialog box is closed, you can open the Recent tab by clicking one of the following:

- **Open**  > **Browse Recent Documents**
- **File** > **Open Recent** > **Browse Recent Documents**

Folders

The **Recent Folders** section includes a list of folders from which you have opened documents recently.

You can do the following:

- Click a folder to open the folder in the Open dialog box.
- Hover over a folder and click  to keep the folder at the top of the list.
- Right-click a folder and click **Remove**, **Pin**, or **Clear unpinned items**.
- Click **Browse** to open the Open dialog box for the current folder.





If the Welcome dialog box is closed, you can open the Recent tab by clicking **File** > **Open Recent** > **Browse Recent Folders**.

Learn Tab

The Learn tab lets you access instructional resources to help you learn more about the SOLIDWORKS software.

Sections in the Learn tab include:

Introducing SOLIDWORKS	Opens the <i>Introducing SOLIDWORKS</i> book.
Tutorials	Opens the step-by-step tutorials in the software.

MySolidWorks Training	Opens the Training section at MySolidWorks.com.
Samples	Opens local folders containing sample models.
3DContentCentral	Opens 3DContentCentral.com.
 Online Tutorials	Opens the SOLIDWORKS Tutorials (videos) section at solidworks.com.
 My Training	Opens the My Training section at MySolidWorks.com.
 Certification	Opens the SOLIDWORKS Certification Program section at solidworks.com.
 Curriculum	Opens the Curriculum section at solidworks.com.

When you install the software, if you do not install the **Help Files** or **Example Files**, the **Tutorials** and **Samples** links are unavailable.

Alerts Tab

The Alerts tab keeps you updated with SOLIDWORKS news.

Sections in the Alerts tab include **Critical**, **Troubleshooting**, and **Technical Alerts**.

Critical

The **Critical** section includes important messages that used to appear in a dialog box.

The **Critical** section appears if there are critical alerts to display. If a critical alert exists, the Welcome dialog box opens to the **Critical** section automatically on startup, even if you selected **Do not show on startup** in the dialog box. Alerts are displayed until you select **Do not show this message again**.

Troubleshooting

The **Troubleshooting** section includes troubleshooting messages and recovered documents that used to be on the SOLIDWORKS Recovery tab in the Task Pane.

The **Troubleshooting** section appears if there are crash diagnostic messages or recovered documents to display. If the software has a technical problem and an associated troubleshooting message exists, the Welcome dialog box opens to the **Troubleshooting** section automatically on startup, even if you selected **Do not show on startup** in the dialog box.

Technical Alerts

The **Technical Alerts** section opens the contents of the SOLIDWORKS Support Bulletins RSS feed at solidworks.com.

3

SOLIDWORKS Fundamentals

This chapter includes the following topics:

- **Adobe Illustrator Creative Cloud Files**
- **Application Programming Interface**
- **Default Templates for New Documents**
- **Include or Exclude Suppressed Components in Pack and Go**
- **Rebuild Tools**
- **Selecting Over Geometry**
- **Support for 3D Printing Models Containing Surface Bodies and Graphics Bodies**

Adobe Illustrator Creative Cloud Files

SOLIDWORKS supports the Adobe Illustrator Creative Cloud platform. You can import Creative Cloud files using the SOLIDWORKS application.

Application Programming Interface

See *SOLIDWORKS API Help: Release Notes* for late-breaking updates.

SOLIDWORKS 2018 API includes the ability to:

- Access general tolerance table annotations and features.
- Access hidden content in tables.
- Add a distance mate between cylindrical components of an assembly.
- Add and edit pairs of concentric mates (hole sets) between the same two components, allowing for misalignment of concentric mates.
- Add rebuild and save marks to multiple configurations and remove them from all configurations.
- Add specific display dimensions by type.
- Create a spline constrained to a surface.
- Create a trimmed sheet body with a specified tolerance.
- Create advanced assembly mates and sweeps using improved API architecture.
- Create advanced holes in parts.
- Create and upgrade VB.NET and C# macros using Microsoft Visual Studio® Tools for Applications (VSTA) 2015.
- Create bidirectional twist and thin-walled sweep features.
- Create internal and external threads.

- Edit third-party native CAD components in assemblies.
- Expand and collapse indented items in BOMs.
- Get corresponding objects between drawing views and parts or assemblies.
- Get, edit, insert, or delete the below frame text of geometric tolerances.
- Get layer items by type.
- Get or set a custom property builder template for parts or weldments.
- Get or set component display state-specific properties in multiple assembly display states.
- Get or set geometric tolerance leader options, **All Over This Side** and **All Around This Side**.
- Get or set the balloon padding for existing notes in drawings.
- Get or set whether a configuration node is expanded in the ConfigurationManager.
- Get or set whether table text is all upper case.
- Get or set whether to automatically rebuild equations.
- Get or set whether to automatically repair files on opening.
- Get or set whether to display configuration names and descriptions in the ConfigurationManager.
- Get or set whether to import DimXpert annotations when inserting or mirroring parts.
- Get or set whether to lock a magnetic mate.
- Get or set whether to show a slit in the corner relief of **Flat-Pattern** features.
- Get whether a custom property is editable in a configuration.
- Handle pre- and post-notify events when converting bodies.
- Import and export Hole Wizard and Toolbox data.
- Modify control points and interior knots in sketch splines.
- Offload PhotoView 360 rendering to other networked machines.
- Optionally rebuild a model after adding configurations.
- Override default part or assembly templates when creating a **Split** feature.
- Quickly check whether an interference exists between components.
- Save and restore the current SOLIDWORKS software settings.
- Select exploded views, create a regular explode step with rotation parameters, create a radial explode step, and edit explode steps.
- Set table anchors at selected sketch points on drawing sheets.
- Set whether to expand all configurations in a specified pane of the ConfigurationManager.
- Show the preview of a configuration selected in the ConfigurationManager.

Default Templates for New Documents

The templates specified in **System Options > Default Templates** are always used when you create new documents directly from the Novice page of the New SOLIDWORKS Document dialog box or from the Welcome dialog box.

Previously, if you created multiple templates, then depending on the template names and folder locations, those templates might have been used instead of those specified in **Default Templates**. You can still use alternate templates by clicking **Advanced** in the New SOLIDWORKS Document dialog box or the Welcome dialog box.

Include or Exclude Suppressed Components in Pack and Go

This new option makes it easier for you to package a simplified copy of an assembly for analysis, rendering, or other purposes, and to exclude proprietary components that you do not want to share.

Suppressed components appear in the grid with the [Suppressed] notation. Clear **Include suppressed components** to remove these from the grid and the target Pack and Go file or folder. The suppressed components will still appear in the FeatureManager of the packaged assembly, but their corresponding files will be excluded.





You can also include or exclude any components suppressed in the active configuration, along with decals, drawings, and simulation results associated with those components.

This option is only available when you launch Pack and Go from the SOLIDWORKS **File** menu.

Rebuild Tools

The **Force Regen** and **Force Regen the Top Level Assembly** tools have been renamed to use the word **Rebuild** instead of **Regen** so that all rebuild tools use consistent terminology.

The tools include:

	Rebuild	Rebuilds changed features.
	Rebuild All Configurations	Rebuilds changed features in all configurations.
	Force Rebuild	Rebuilds all features.
	Force Rebuild All Configurations	Rebuilds all features in all configurations.
	Force Rebuild Top Level Assembly	Rebuilds all features in the top level assembly.

Forced rebuilds can take significantly more time, depending on model complexity.

The **Force Rebuild** toolbar buttons are located on the Standard toolbar. You can add the tools to the CommandManager, shortcut bars, and mouse gestures.

Keyboard shortcuts for **Ctrl + Q** and **Ctrl + Shift + Q** remain unchanged. This table shows the various keyboard shortcuts:

	Part	Assembly	Drawing	Sketch
Rebuild	Ctrl + B	Ctrl + B	Ctrl + B	Ctrl + B
Rebuild All Configurations	Ctrl + Shift + B	Ctrl + Shift + B		Ctrl + Shift + B
Force Rebuild	Ctrl + Q		Ctrl + Q	Ctrl + Q
Force Rebuild All Configurations	Ctrl + Shift + Q	Ctrl + Shift + Q		Ctrl + Shift + Q
Force Rebuild Top Level Assembly		Ctrl + Q		

Selecting Over Geometry

The **Select over Geometry** tool lets you drag a box or lasso over a model without starting the drag from a blank region of the graphics area.

Select over Geometry is helpful when you cannot start the drag from a blank region. For example, use it when the model fills the graphics area or when unwanted items would be included in the selection.

Without **Select over Geometry**, if you start the drag on top of geometry, the drag fails and the geometry under your initial click is selected:

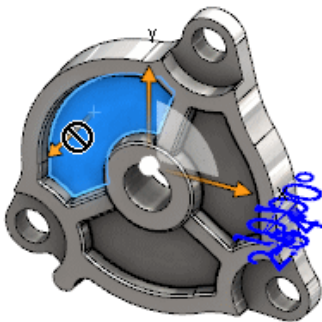

To select over geometry:

- Do one of the following:
 - Click **Select over Geometry**  (Standard toolbar).
 - Click **Tools > Select over Geometry**.
 - Press and release **T**.

Select over Geometry is also available in mouse gestures.

Select over Geometry mode is activated.

2. Drag a box or lasso around the items to select.



The geometry is selected:



When **Select over Geometry** mode is active, you can do the following:

- Drag a box or lasso to clear the current selection and select different items.
 - **Shift** + drag a box or lasso to add items to the current selection.
 - Perform an operation on the current selection (for example, add fillets to selected edges), and then drag a box or lasso to make another selection.
3. To exit **Select over Geometry** mode, do one of the following:
 - Click anywhere in the graphics area (for example, on a face or edge, or in a blank region).
 - Click **Select over Geometry**  (Standard toolbar) or **Tools** > **Select over Geometry**.

Support for 3D Printing Models Containing Surface Bodies and Graphics Bodies

SOLIDWORKS supports 3D printing of models that contain surface bodies and graphics bodies only if they form a watertight manifold volume.

Previously, 3D printing of surface and graphics bodies was not supported and you could only 3D print solid bodies. Now, you can 3D print surfaces or graphics bodies provided they form a watertight manifold volume. Bodies that do not form a watertight manifold volume are temporarily hidden and bodies that form a watertight manifold volume get 3D printed.

To 3D print a model, click **File** > **Print3D** .

4

Installation

This chapter includes the following topics:

- **Installing SOLIDWORKS CAM**
- **Installing SOLIDWORKS Manage Professional**
- **Upgrading SOLIDWORKS PCB Services**

Installing SOLIDWORKS CAM

SOLIDWORKS CAM is a manufacturing application that creates CNC programs to machine your SOLIDWORKS parts and assemblies. It supports mill, turn, and mill assembly machining. It is installed by SOLIDWORKS Installation Manager as part of the **Individual** installation.

SOLIDWORKS CAM converts the design view of parts created by the SOLIDWORKS software to a manufacturing view. It uses the part or assembly file to create machinable features and generate toolpaths. When you update the model, those changes are automatically reflected in the toolpaths.

Installing SOLIDWORKS Manage Professional

SOLIDWORKS Manage Professional provides advanced data management tools to SOLIDWORKS PDM Professional.

It offers capabilities for advanced version control, and for project, process, and item management. Interactive dashboards and reports help you track items, activities, and progress toward completing projects.

SOLIDWORKS Manage Professional has a similar architecture as SOLIDWORKS PDM Professional. It uses a client-server architecture, with a Microsoft SQL Server database to manage item and project data.

There are three services for database, file server, and web server functions, which support both thick clients and web browser clients. The three services can be hosted on the same server or separate servers. Users with SOLIDWORKS Manage Professional Editor licenses can use a SOLIDWORKS Manage Add-in to access Manage data directly from within SOLIDWORKS.

You can use the SOLIDWORKS Installation Manager to install the SOLIDWORKS Manage Professional server and client.

For instructions on installing SOLIDWORKS Manage Professional, see the *SOLIDWORKS PDM/SOLIDWORKS Manage Installation Guide*.

Upgrading SOLIDWORKS PCB Services

When you are upgrading SOLIDWORKS PCB Services to 2018, the SOLIDWORKS Installation Manager upgrades the Firebird database from release 2.0 to 3.0, and automatically migrates your data. Before upgrading, you should make a manual backup of the database.

5

Administration

This chapter includes the following topics:

- **Controlling Dismissed Messages**
- **Displaying Document Open Time in Windows Explorer**
- **Specifying a Template for General Tables**
- **Synchronizing Settings and Options Across Multiple Machines**
- **Task Scheduler Supports Additional File Formats**

Controlling Dismissed Messages

The Settings Administrator Tool lets you manage common dismissed messages by users.

When you run the Settings Administrator Tool, you can block users from dismissing messages by applying controls for **Messages/Errors/Warnings**. You can ensure that some error messages and warnings always display or never display. These settings are saved in the *.sldSettings file.

The Settings Administrator Tool was introduced in the previous release. Administrators can use the tool to set system options when deploying the SOLIDWORKS software. It is available when you install an **Administrative Image** and is stored in the following default location: C:\SolidWorksAdmin\SOLIDWORKS<version>\64bit\SOLIDWORKS\Program Files 64\SOLIDWORKS\sldSettingsAdmin.exe.

To enable control of dismissed messages:

1. Launch the Settings Administrator Tool and in the System Options tab, click **Messages/Errors/Warnings**.
2. Check **Apply** and optionally check **Lock**  for the messages you want to manage.

3. Set the message to **Show** or **Don't Show**.

If you select **Show**, the message is removed from a user's dismissed message list, and displays to the user at the appropriate time. If you select **Don't Show**, the message is automatically added to a user's dismissed messages list, and does not display when the user is working on a model.

This table describes the behavior in the software:

Apply	Lock	Show	Don't Show	Behavior
X		X		Force the message to show.
X			X	Dismisses the message and adds the message to the dismissed message list.
X	X	X		Forces the message to show and disables the option to Don't show again in the message box.
X	X		X	Dismisses the message and bars user from enabling it in Tools > Options > Messages/Errors/Warnings .

4. When you choose **Don't Show**, you must also select a response to the silenced prompt. The response to a message might be **OK**, **Yes**, **No**, or a short text string.

Users can override locked settings if you supply them with a password. When users hover over a lock icon in **Messages/Errors/Warnings**, a dialog box prompts for a password. With this password, users can unlock a message, and remove or add a message from their dismissed messages list.

Displaying Document Open Time in Windows Explorer

The file property, **Last Open Time**, appears in a tooltip when you hover the pointer over a SOLIDWORKS part, assembly or drawing document in Windows Explorer.

Last Open Time displays the time it took for the SOLIDWORKS software to open the file, the last time it was opened. This file property is helpful for managing your time when you have large data sets that are time consuming to open.

The time displays in minutes and seconds, and is available for models which are opened directly from disk saved in SOLIDWORKS 2018. For assemblies opened in Lightweight mode, the tooltip displays **Last LW Open Time**.

Last Open Time does not update in reference files when they are saved while open in memory, but does update when the reference files are saved while open in their own window.

You can also add a column in the Details view of Windows Explorer to display **SW Open Time**, and you can identify files saved in earlier versions of the SOLIDWORKS software by adding a column for **SW Last Save with**.

If you are running Windows 10, Windows Explorer has been renamed to File Explorer. These instructions also apply to File Explorer.

To add columns for SW Open Time and SW Last Save with in Windows Explorer:

1. Open a folder with SOLIDWORKS documents.
The contents of that folder appear in the Details view of Windows Explorer.
2. In the Details view, right-click on the header. Typically, the header displays columns for **Name**, **Type**, and **Size**. Then in the context menu, select **More**.
The Choose Details dialog box appears.
3. Under **Details**, scroll to **SW Last Save With** and **SW Open Time**. You can select one or both options.
4. Click **OK**.

Specifying a Template for General Tables

You can specify a file path for a general tables template in **Systems Options > File Locations**. This template helps users to consolidate styles and formatting.

Previously, users could not specify a file location for a general tables template.

Synchronizing Settings and Options Across Multiple Machines

If you use the SOLIDWORKS software with multiple machines, you can update your settings on any of the machines and synchronize those settings across all machines that run SOLIDWORKS 2018.

Settings synchronization is a service and may be blocked by some network configurations. To access the cloud storage service, ensure that firewall or proxy servers allow communications to *.solidworks.com.

To synchronize settings and options across multiple machines:

1. Log in to the SOLIDWORKS software.
See [Logging into SOLIDWORKS](#) on page 19.
2. In **Tools > Options**, click **Synchronize Settings**.

3. Choose a manual or automatic method:

- **Synchronize Now**

Upload Settings. Sends your settings from the current machine to the cloud storage service. Update your settings in the cloud at any time by uploading them again.

Download Settings. Downloads and applies your settings from the cloud storage service to the current machine.

- **Automatic Synchronization**

Automatically synchronizes the current machines with the cloud storage service. Your selected settings and customizations automatically upload to the cloud storage services as they are updated, and downloaded and applied on startup or login.

Synchronization settings can vary on different machines. For example, you can specify one machine to automatically synchronize system options and file locations, but not customizations. On another machine, you can specify to manually download and upload all types of settings.

With the synchronization process, you cannot overwrite administrator settings that are applied or locked.

4. Click **OK**.

Task Scheduler Supports Additional File Formats

The Task Scheduler imports and exports additional file formats.

The following tables list the different types of files you can import and export using the SOLIDWORKS software:

Formats for Import	Extension
Parasolid	.x_t; .x_b; .xmt_txt; .xmt_bin
IGES	.igs; .iges
STEP	.stp, .step
ACIS	.sat
VDAFS	.vda
SLDXML	.sldlm
Rhino	.3dm

For IGES, STEP, ACIS and SLDXML files, you have an option to run import diagnostics and to import multiple bodies as parts.

Formats for Export	Extension
Parasolid	.x_t, .x_b
ACIS	.sat
VDAFS	.vda
VRML	.wrl
STL	.stl
3D Manufacturing Format	.3mf
Microsoft XAML	.XAML
CATIA Graphics File	.cgr
HOOPS HSF	.hsf
HCG	.hcg

Certain file types have their own tab in the Task Scheduler where you can select more options for export.



6

Assemblies

This chapter includes the following topics:

- **Asset Publisher and Magnetic Mates Enhancements**
- **Changing the Transparency of an Assembly or Multibody Part**
- **Check Entity Enhancements**
- **Mates**
- **Misaligned Mates**
- **Motion Study Menu Enhancements**
- **Pattern Enhancements**
- **Performance Evaluation Enhancements**
- **Smart Explode Lines**
- **SpeedPak**
- **Treehouse Enhancements**

Asset Publisher and Magnetic Mates Enhancements

- You can define multiple ground planes  in an assembly. You can have only one active ground plane at a time. Components with magnetic mates and a defined ground plane are placed on the active ground plane.
- When inserting a component with a magnetic mate, you can cycle through the connection points by using keyboard shortcuts. Use the left bracket [to cycle through connection points on the moving component. Use the right bracket] to cycle through connection points on the static component.
- After inserting a component with a magnetic mate, you can enable the magnetic mate lock by clicking the Lock mate  icon near the cursor.

Defining Multiple Ground Planes in an Assembly

An arrow indicates the active ground plane. You can add a ground plane or activate a different ground plane.



To add a ground plane:

1. Click **Insert** > **Reference Geometry** > **Ground Plane**.

For assemblies that have an existing ground plane, right-click the Ground Planes folder  in the FeatureManager design tree, and click **Insert Ground Plane**.

2. Select a ground plane.
3. Click .

To activate a ground plane:

1. In the FeatureManager design tree, expand the Ground Planes folder .
2. Double-click the ground plane  that you want to activate, or right-click the ground plane and click **Activate**.

Using the Keyboard Shortcuts



To use the keyboard shortcuts to cycle through connection points:

Select the component to use in a magnetic mate. With the component selected, use [or] to cycle through the connection points.

To customize the keyboard shortcuts:

1. Click **Tools > Customize > Keyboard**.
2. In Category, select **Others**.
3. Under Command, select Cycle connection point (moving component) or Cycle connection point (static component) to change the keyboard shortcut.

Changing the Transparency of an Assembly or Multibody Part

You can change the transparency of all components in an assembly or in a multibody part. Multibody parts and components that display in **Shaded**  or **Shaded with Edges**  modes change from opaque to transparent.

To change the transparency, right-click the assembly and click **Top Level Transparency**  on the context toolbar.

For components that are transparent when you change the assembly to transparent:

- If you do not change the transparency of the component, the component remains transparent when you change the assembly to opaque.
- If you change the transparency of the component, the component becomes opaque when you change the assembly to opaque.

Check Entity Enhancements

For assembly documents, the Check Entity dialog box returns information about the component name if an assembly contains components that have undesirable geometry.

Examples of undesirable geometry include invalid faces, invalid edges, short edges, minimum radius of curvature, edge gaps, and vertex gaps.

To exclude checks for open surfaces in an assembly, clear the **Open surface(s)** option. Use the **Isolate** command to isolate the components that have undesirable geometry.

To isolate a component:



1. With an open assembly, click **Check**  (Tools toolbar) or **Tools > Evaluate > Check**.
2. Click **Check** to check for components that have undesirable geometry.
3. Select a component from the Result list to highlight the component in the graphics area. Information about the component appears in the message area.
4. Click **Isolate** to isolate the component.
5. Click **Exit Isolate** (Isolate pop-up toolbar) to return to the Check Entity dialog box.
6. Click **Close and Isolate faults** to isolate all components that have undesirable geometry when you close the Check Entity dialog box.

Mates

Perpendicular Mates

You can apply a perpendicular mate between a complex, non-analytic surface and a linear entity like a line, an edge, an axis, or an axial entity.

To create a perpendicular mate:



1. Click **Mate**  (Assembly toolbar) or **Insert > Mate**.
2. In the Mate PropertyManager, under Standard Mates, click **Perpendicular**.
3. For **Entities to mate**, select a linear entity and a non-analytic surface.
4. Click  twice to close the PropertyManager.

Temporarily Hiding Faces When Selecting Mates

Use the **Alt** key to temporarily hide a face when you need to select an obscured face for mates.

You can use this keyboard shortcut only with the following Mate commands:

- Insert Mates
- Edit Mates
- Copy with Mates
- Mated Entities

The components must be displayed in **Shaded**  or **Shaded with Edges**  modes. After you select a mate, the hidden faces become visible.

To temporarily hide a face:

1. Click **Mate**  (Assembly toolbar) or **Insert > Mate**.

2. With focus in the graphics area, hover over a face and press **Alt**. The face is temporarily hidden.
3. To show the temporarily hidden face, press **Shift + Alt**.
4. To show all temporarily hidden faces in a semi-transparent state, press **Ctrl + Shift + Alt**.
5. To restore visibility to all temporarily hidden faces, press **ESC**.

Misaligned Mates

Allowing Misaligned Concentric Mates

If you have components with two holes, you can mate those components even when the holes are not the same distance apart.

You can align the mate to resolve exactly with either the first or the second concentric mate and apply the offset to the concentric mate that is not aligned. Or you can apply the offset equally to both sets of mated holes. You can also specify an allowed tolerance, beyond which the misaligned mates over define the assembly and display an error.

To allow misaligned mates:

1. In an assembly, add a concentric mate between the first pair of holes.

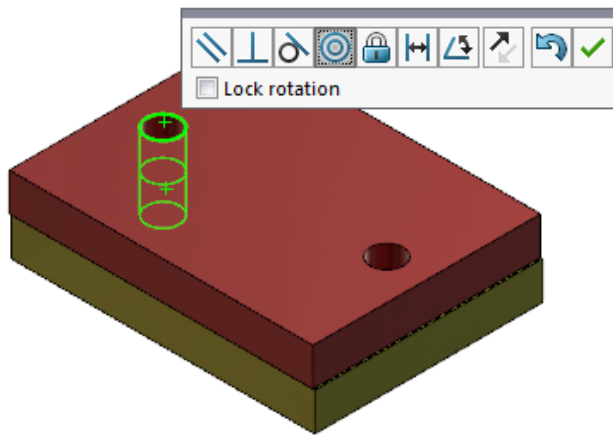

2. Add a concentric mate between the second pair of holes.

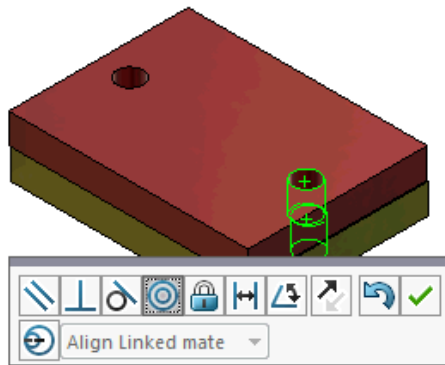

3. In the dialog box, click **Create this mate using misalignment options**.

If you do not see **Create this mate using misalignment options** in the dialog box, go to **Tools > Options > System Options > Assemblies** and select the **Allow creation of misaligned mates** option.

4. In the PropertyManager, select **Align Linked mate** for the misalignment type.
5. Click .

In the graphics area, you can click **Section View**  (Heads-up View toolbar) and zoom to view the edges of each mate. Notice the gap between the surface and edge in the second mate.

First mate solves exactly

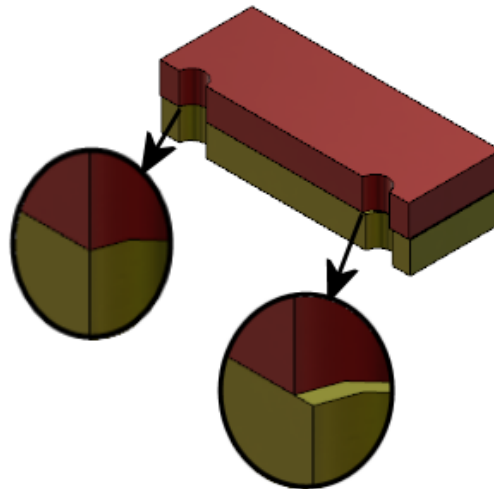

Second mate displays misalignment distance

In the FeatureManager design tree, the two concentric mates show in a Misaligned folder  under the Mates folder.

Assemblies System Option for Misaligned Mates

You can enable or disable the creation of misaligned mates in System Options.

To allow creation of misaligned mates:

1. Click **Tools > Options > System Options > Assemblies**.
2. Select **Allow creation of misaligned mates**.

Document Properties - Mates

You can specify document properties for misaligned mates.

With an assembly open, click **Tools > Options > Document Properties > Mates**.

Misaligned mates

Maximum deviation	Specify the maximum deviation allowed for misaligned mates.
Default misalignment	Select a default misalignment type:
Align first concentric mate	Solves the first concentric mate exactly, and applies all the misalignment to the second concentric mate.
Align second concentric mate	Solves the second concentric mate exactly, and applies all the misalignment to the first concentric mate.
Symmetric	Applies half of the misalignment to each concentric mate.

Motion Study Menu Enhancements

Motion symbols automatically appear when you export animations of motion studies.

You can hide or show motion symbols for motion studies by selecting **View > Hide/Show > Motion Symbols** .

Pattern Enhancements

Including Material and Visual Properties in a Mirrored Part

When you mirror a part from a part environment or an assembly context, you can select the material and the visual appearance of the part to include in the derived part.

In the Mirror Components PropertyManager, the **Material** option is selected by default. To change the material of the derived part, clear the **Material** option.

The **Propagate from original part** option in the Visual Properties section mirrors color assignments from the parent part to the derived part. Mirrored colors include colors assigned to the part, bodies, features, and faces.

The **Material** and **Propagate from original part** options are available only when you mirror a part or when you insert a part into another part for the first time. These options are not available when you edit the mirror feature or the inserted part.

Select material and visual appearance to include in a derived part:

1. Click **Mirror Components**  (Assembly toolbar) or **Insert > Mirror Components**.
2. In the PropertyManager, follow the steps to create a mirror pattern.

Click **Create opposite hand version** in **Step 2: Set Orientation** to continue through the PropertyManager.

3. In **Step 4: Import Features**, under Transfer, select **Material**. Under **Visual Properties**, select **Propagate from original part**.
4. Click  to create the mirrored component.

Linear Pattern Enhancements

Use linear patterns to rotate pattern instances along a pattern direction.





You can rotate instances as follows:

- Rotate instances based on an input value.
- Rotate instances about a selected axis.
- Align rotated instances to the seed instance.

To rotate a linear pattern along pattern Direction 1:

1. Click **Linear Component Pattern**  (Assembly toolbar) or **Insert > Component Pattern > Linear Pattern**.
2. In the Components to Pattern section, add a component to pattern.

3. In the PropertyManager, select options under **Direction 1**:

	Pattern Direction	Defines the direction to extend the pattern. Select a linear edge or a linear dimension.
	Number of Instances	Specifies the total number of instances including the seed components.
	Rotate instances	Rotates the instances based on an input value around a selected axis.
	Axis of rotation	Specifies the axis that the pattern rotates around. The axis must be parallel to Direction 1.
	Reverse Direction	Reverses the direction of the rotation.
	Angle	Specifies the angular increment for each pattern instance.
	Align to seed	Aligns each instance to match the original alignment of the seed feature.
	Reference point	Select a reference point: <ul style="list-style-type: none">• Bounding box center• Component origin These options appear when you select Align to seed .

4. Click .

Performance Evaluation Enhancements

Assembly Open Progress Indicator

The Assembly Open Progress indicator provides information on the status of operations while you open an assembly.

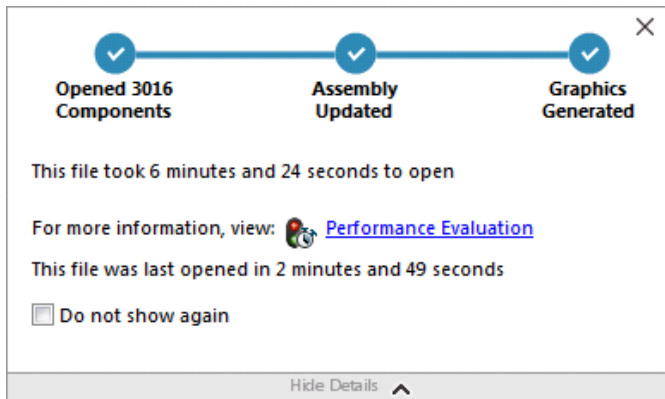

For assemblies that take longer than 60 seconds to open, the indicator remains open after the assembly opens.

The indicator provides information on the following operations:

Open Components	Loads the top-level assembly and reference documents. Shows the number of components opened and the total number of files in the assembly.
Update Assembly	Updates models including mates, assembly features, patterns, and in-context models.
Update Graphics	Generates graphics.
Elapsed time	Shows the amount of time required to open the assembly.
Previous time to open	Shows the amount time required to open the assembly the last time the assembly was opened. The Previous time to open operation is specific to the assembly mode. This information is saved for Large Assembly mode, Lightweight mode, and Resolved mode.



After opening the assembly, click **Performance Evaluation** in the indicator dialog box to view performance information specific to opening the assembly. To view the performance information at a later time, click **Tools > Evaluate > Performance Evaluation**.

You can suppress the Assembly Open Progress indicator by selecting **Do not show again**. To restore the progress indicator, click **Tools > Options > System Options > Messages/Errors/Warnings**, and select **Assembly Open Progress Indicator**.





If you enable the **No preview during open (faster)** option, the **Do not show again** option does not appear. To disable the **No preview during open (faster)** option, click **Tools > Options > System Options > Performance** to clear the option.

Assembly Visualization Enhancements

The Assembly Visualization tool includes a set of predefined columns to help troubleshoot assembly performance. You can view the open and rebuild times for the components, and the total number of graphics triangles for all instances of components.

Other enhancements include the addition of a **Performance Analysis**  button, and moving the buttons to the same line as the Filter field . An updated user interface improves the usability by using more readable text and icons.

To view Performance Analysis information:

1. Click **Assembly Visualization**  (Tools toolbar or Evaluate tab on the CommandManager) or **Tools > Evaluate > Assembly Visualization**.
2. On the Assembly Visualization tab , click the **Performance Analysis**  button. You can also click the arrow  to the right of the column headers and click **Performance Analysis**.

The following columns appear:

- **File Name**
- **Quantity**
- **Total Graphics-Triangles**
- **SW-Open Time**
- **SW-Rebuild Time**

Performance Evaluation Tool Enhancements

Performance Evaluation provides more information on the open, display, and rebuild performance of models in an assembly.

To open the Performance Evaluation tool:

- Click **Performance Evaluation** in the Assembly Open Progress Indicator dialog box.
- Click **Tools > Evaluate > Performance Evaluation**.

New Performance Evaluation checks that are available:

Document Open File Details	Lists files by the amount of time required to open the file.
Modified on Open	Indicates the number of files that are updated while the assembly opens. Click Show These Files  to view the list of updated files.

Graphics Triangles Lists files by the number of graphic triangles contained in a part.
Files with less than 5,000 graphic triangles are not listed.

Shaded Image Quality Lists the files where image quality is medium-high or very high. Click  **Show These Files** to view a list of affected files.

For image quality, click **Tools > Options > Document Properties > Image Quality**. In the Shaded and draft quality HLR/HLV resolution section, move the **Low (faster) - High (slower)** slider to change the image resolution.

Parts with very high image quality have the slider set at 80% or greater. Parts with medium-high image quality have the slider set at 60% - 80%.

If the list of files does not appear, go to **Tools > Options > Document Properties > Image Quality** and clear the **Apply to all referenced part documents** option. A message about assembly image quality appears when you have the **Apply to all referenced part documents** option selected and meet the following conditions:

- **Shaded and draft quality HLR/HLV resolution** slider is set above sixty percent.
- Number of components in the assembly is equal or above the Large Assembly Mode threshold.

Appearance Displays a warning if a file contains over 100 appearances applied to faces. Click **Show These Files**  to view the list of affected files.

Performance Evaluation checks are organized in the following categories:

Open Performance

- Open Summary
- Document Open File Details
- Previous Version References
- Modified on Open

Display Performance

- Graphics Triangles
- Shaded Image Quality
- Display Speed
- Appearance
- Components Far From Origin

Rebuild Performance

- Rebuild Data Unavailable
- Rebuild Report
- Mate
- In-Context Part Performance
- In-Context Relationship Performance
- In-Context Relationship Conflict
- Assembly Rebuild Report

In SOLIDWORKS 2018, the In-Context Circular References check is renamed to Assembly Rebuild Report.

Settings Performance

- Verification on Rebuild
- Large Assembly Mode

Statistics

- Parts
 - Subassemblies
 - Components
 - Assembly
-

Click **Assembly Visualization** to open the Assembly Visualization tool.

Smart Explode Lines

Creating and Dissolving Smart Explode Lines

You can create smart explode lines automatically for components in an exploded view.

You can view the associated explode steps for a selected component in the Smart Explode Lines PropertyManager. Smart explode lines use the bounding box center as a reference point by default.





You can use smart explode lines along with manually created explode lines. To use a different path for an explode line, you must manually create the explode line or dissolve the smart explode line. You cannot add a component to the explode steps using the Smart Explode Lines PropertyManager.

When you change the explode steps, the smart explode lines update automatically.

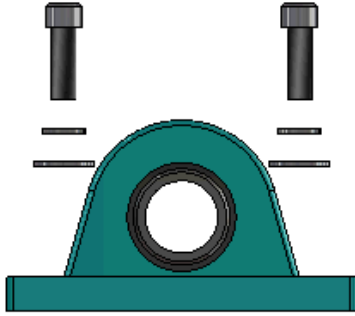
To create smart explode lines:





1. Open an assembly that contains an exploded view.

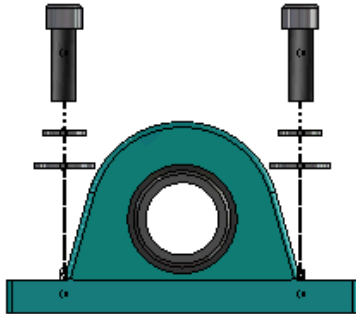

2. On the ConfigurationManager  tab, expand the active configuration.
 3. Right-click the **ExpView**  feature and click **Smart Explode Lines** .
 4. In the Smart Explode Lines PropertyManager, click .
- The exploded view contains the smart explode lines.





To edit smart explode lines:

1. On the ConfigurationManager  tab, expand the active configuration.
2. Right-click the **ExpView**  feature and click **Edit Smart Explode Lines** .
3. In the Smart Explode Lines PropertyManager, modify the settings for the smart explode lines.
4. Click .

Dissolving Smart Explode Lines

To change a line created by using the **Smart Explode Lines** option, you must dissolve the smart explode line.

To dissolve a smart explode line:

1. On the ConfigurationManager  tab, expand the active configuration.
2. Expand the **ExpView**  feature.
3. Right-click the **3DExplode**  sketch and click **Edit Sketch**.

When you edit the sketch, the smart explode lines appear in the color selected for the **Highlight** setting. To change this color, click **Tools > System Options > Colors**. In the Color scheme settings section, select **Highlight**.

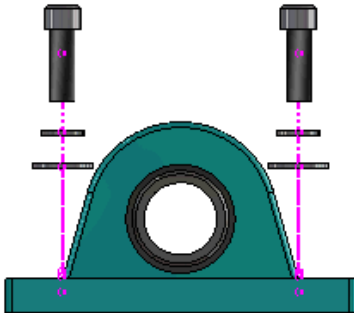



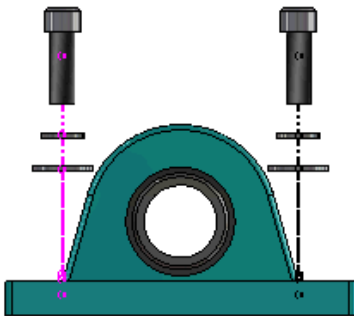

4. Right-click the smart explode line and click **Dissolve Entities** .

In the following image, the route line on the right side is dissolved. The route line on the left side remains a smart explode line.



To dissolve all smart explode lines:



1. On the ConfigurationManager  tab, expand the active configuration.
2. Expand the **ExpView**  feature.
3. Right-click the **3DExplode**  sketch and click **Dissolve Smart Explode Lines** .

To edit the lines, you must edit the sketch.

Smart Explode Lines PropertyManager

In an assembly exploded view, you can create explode route lines automatically for selected components by using the Smart Explode Lines PropertyManager.

To open the Smart Explode Lines PropertyManager:

1. On the ConfigurationManager  tab, expand the configuration.
2. Right-click the **ExpView**  feature and click **Smart Explode Lines** .

If smart explode lines already exist, click **Edit Smart Explode Lines**.

Components

Components	Select the components that have an associated explode step.
Apply to all component instances	<p>Copies the explode line options from one component to the other instances of the same component. This functionality is available when:</p> <ul style="list-style-type: none"> • The Component origin option in the Component Route Line section is selected. • The Components section contains at least one other instance of the selected component. The configuration and display state of the other component instance must match the configuration and display state of the selected component. • The explode steps of the other instances match the explode steps of the selected component.
	<p>The comparison of the explode steps occurs in the parent explode view. The comparison does not occur in the Explode Step check boxes.</p>
Select the subassembly parts	When selected, enables you to select individual components of a subassembly. When cleared, enables you to select an entire subassembly.

Component Route Line

Bounding box center	Locates the explode line relative to the bounding box center of the selected component.
Component origin	Locates the explode line relative to the origin of the selected component.
Selected point	Locates the explode line relative to the selected point.
Select reference point	Select a point to use for the Selected point . The selected point can be a point, a vertex, a sketch arc, an edge arc, a sketch line, or an edge line.

Explode Steps

Explode Step	Lists the explode steps in order.
Route line	Select the explode steps to include in the route line.

SpeedPak

Setting a Rebuild on Save Mark on SpeedPak Configurations

You can set a Rebuild on Save mark  on a SpeedPak Configuration in multiple ways.

Setting a Mark in the ConfigurationManager

1. On the ConfigurationManager  tab, right-click the assembly and click **Rebuild on Save Mark**.
2. Select **Add Mark for SpeedPak Configurations**.

Setting a Mark in the SpeedPak PropertyManager

1. On the ConfigurationManager  tab, under the active configuration, right-click an existing SpeedPak configuration and click **Edit SpeedPak**.
2. In the SpeedPak PropertyManager, select **Add Rebuild on Save Mark** in the Options section.

Updating SpeedPak Configurations Automatically

You can use the **Update out-of-date SpeedPak configurations when saving files** option to automatically update SpeedPak configurations. You can lock this option in the Settings Administrator Tool.

Use this option on top-level assemblies. This option does not work for subassemblies.

To specify the Update out-of-date SpeedPak configurations when saving files option:

1. Click **Tools > Options > System Options > Assemblies**.

2. For **Update out-of-date SpeedPak configurations when saving files**, select one of these options:

All	Update all out-of-date SpeedPak configurations.
None	Do not update any out-of-date SpeedPak configurations.
With Rebuild on Save mark	Update out-of-date SpeedPak configurations that have the Rebuild on Save mark  .

Treehouse Enhancements

Display Files in a List View

You can perform many of the same tasks in the list view that you perform when viewing the Treehouse structure in the graphical user interface:

- To open a file, right-click the icon in the Type column and click **Open**.
- To hide a column, right-click a column heading and clear the column entry. To reorder columns, drag the column.
- To save an existing document as a new copy, double-click the document name and change the name.

The document name turns green to indicate that the document is saved as a new document.

When saving an existing document as a new copy, you must work from the top down. For example, if you have an existing assembly document in the hierarchy and you want to save a component of that assembly as a new document, you must first save the assembly as a new document.

- For new documents, to change the file path in the Destination Folder Path column, click **Select the Save to Folder**  and select the destination folder.

A new document can have the same name as an existing document when the Destination Folder Path is different.

- To open the Treehouse structure in Microsoft® Excel, click **Open in Excel** .

To display files in a list view:

1. Click **Display in a List view**  to open the list view.

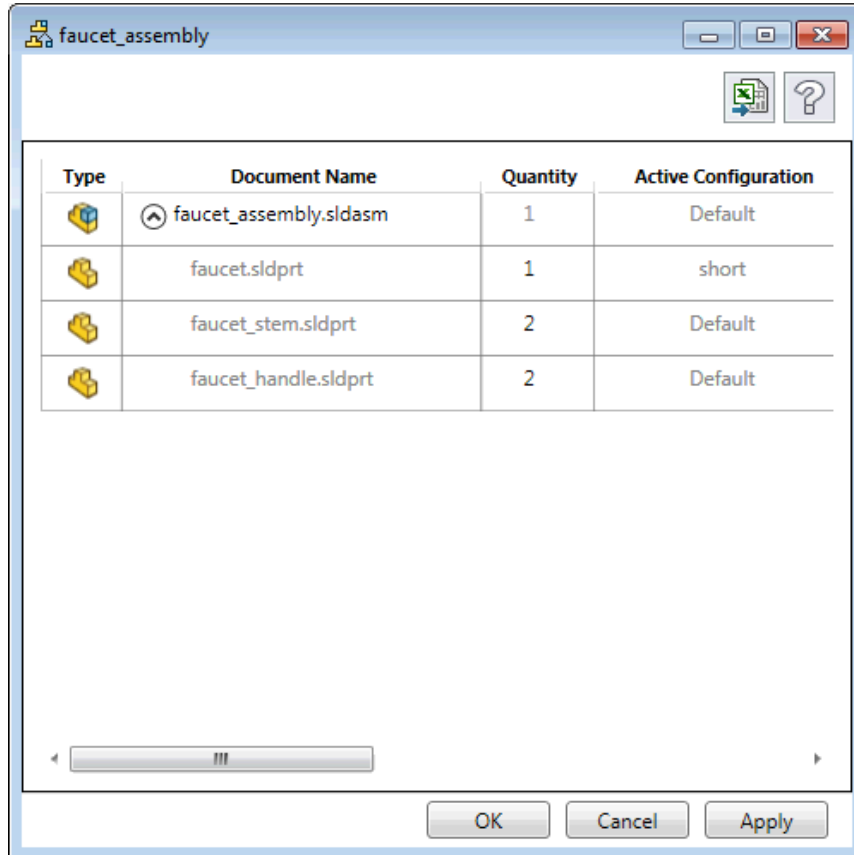

In the List view, suppressed files are not shown and you cannot change the active configuration.

To change the active configuration:

1. In the graphical user interface, hover over an assembly and click
2. In the configuration list, select the configuration to switch from.
3. In the drop-down list, select a configuration to switch to.
4. Click **Switch**.

Hiding Suppressed Documents

You can hide suppressed documents to simplify the assembly structure that appears in Treehouse.





To hide suppressed documents:



1. Click
2. Clear **Display the suppressed documents** in the View section.
3. Click **Apply** and then **OK**.

Print Options

Click **Print**  to view these options:

	Print Extents	Prints to the extents of the structure.
	Print Display	Prints the part of the extents that are displayed. Use Zoom to Area  to print a specific part of an extent.
	Print Preview	Shows a preview of the current print selection. The preview is based on the paper size, scale, and orientation.

User Interface

User interface enhancements include:

- To view a specified area of the Treehouse structure, click **Zoom to Area** .
- Double-click the middle mouse button to zoom extents.

7

SOLIDWORKS CAM

This chapter includes the following topics:

- **Documentation**
- **Rebranding**
- **Setting Subroutines for Parts**
- **Setting the Toolpath Output Folder**
- **Technology Database**
- **User Interface Improvements**

SOLIDWORKS CAM is offered in two versions. SOLIDWORKS CAM Standard is included with any SOLIDWORKS license that has SOLIDWORKS Subscription Service.

SOLIDWORKS CAM Professional is available as a separately purchased product that you can use with SOLIDWORKS Standard, SOLIDWORKS Professional, and SOLIDWORKS Premium.

Documentation

All documentation, including the installation guide, online help, and tutorials, is available for SOLIDWORKS CAM.

Rebranding

Geometric Ltd. and HCL have merged. All rebranding changes have been completed in the installer, software, registry, and related documents.

Geometric Ltd. is now HCL Technologies Ltd.

Setting Subroutines for Parts

You can set the subroutines to specify whether parts are output in subprogram format or long code.

To set subroutines for parts:

1. In the SOLIDWORKS CAM tree, in the Machine dialog box, click the Posting tab.

- Under **Subroutines**, select an option:

Option	Description
Output subroutines for patterned Features	(Mill module only.) Sets subprograms for mill parts to work for pattern Features.
Output subroutines	(Assembly module only.) Sets subprograms for similar parts in assemblies that are managed in the PartManager.

- Click **OK**.

Setting the Toolpath Output Folder

You can set the toolpath output folder by tool, feature, and part for multiple parts in assemblies.

To set the toolpath output folder:

- In the SOLIDWORKS CAM tree, in the Machine dialog box, click the Setup tab.
- Under **Output multiple parts by**, select an option:

Option	Description
Tool	Processes (posts/simulates) all toolpaths machined by the tool on one part, then repeats the sequence for other part instances. This process starts with the first feature and continues for consecutive operations that use the same tool.
Feature	Processes the toolpath on each instance of a feature before moving to the next feature.
Part	Processes all of the toolpaths on a part, then processes the next part.

- Click **OK**.

Technology Database

Non-supported operations and conditions have been removed from the Technology Database.

User Interface Improvements

Several improvements have been made to the user interface.

CommandManager

For readability, icons of 64, 98, and 128 DPI are available in the CommandManager. In addition, the icons are stacked with horizontal text.

Display Colors

The default display colors have been modified for Stock, Features, Operations, and Simulation.

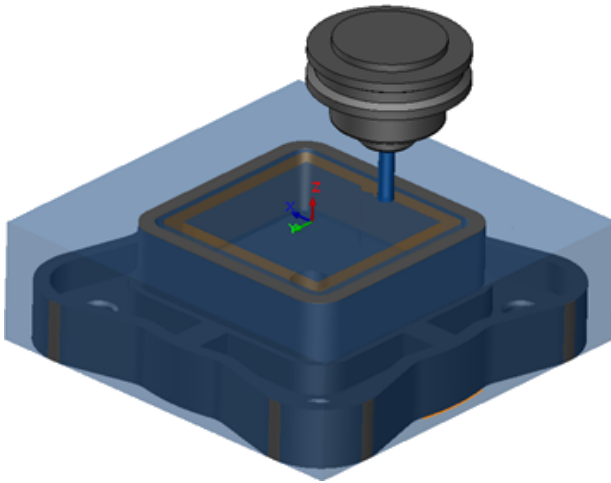

Save Operation Plan

For ease of use, the **Save Operation Plan** tool is available on the CommandManager.

Previously, the **Save Operation Plan**  tool was only available when you right-clicked a feature.

8

CircuitWorks

This chapter includes the following topics:

- **Ability to Recognize SOLIDWORKS Features in CircuitWorks**
- **Building Model as a Part in CircuitWorks**
- **Usability Improvements**

CircuitWorks is available in SOLIDWORKS Professional and SOLIDWORKS Premium.

Ability to Recognize SOLIDWORKS Features in CircuitWorks

When you export SOLIDWORKS board files to CircuitWorks using the CircuitWorks Export Wizard, the Wizard recognizes and translates the SOLIDWORKS features into CircuitWorks terms.

Supported features:

- **Fillet**
- **Chamfer**
- **Cut Extrude Holes/ Simple Holes/ Advanced Holes/ Hole Wizard**
- **Linear Pattern**
- **Sketch Driven Pattern**
- **Curve Driven Pattern**
- **Circular Pattern**
- **Blocks in sketches.**

Editing Hole Features in the CircuitWorks Export Wizard





You can edit individual hole features in the CircuitWorks Export Wizard Task Pane by clearing individual hole selections or renaming instances.

To edit hole features in CircuitWorks:

1. Open `system_dir:\Users\Public\Public Documents\SOLIDWORKS\SOLIDWORKS 2018\samples\whatsnew\circuitworks\BoardFeatures2.sldprt`.
2. In the SOLIDWORKS software, click **Export to CircuitWorks**  (CircuitWorks toolbar) or **CircuitWorks > Export to CircuitWorks**.

3. In the CircuitWorks Export Wizard Task Pane, click **Next** until you reach **Select the Board Outline**.
4. For **Select the Board Outline**:
 - a) Click **Use the following SOLIDWORKS feature**.
 - b)

When you click on the feature, the software converts the feature name to CircuitWorks-specific name. The old name appears under **Selected Feature** and the new name appears under **New Name** in the CircuitWorks Task Pane.

 - In the FeatureManager design tree, select **Board**  and **Fillet1** .
 - c) Click **Next**.
5. For **Select the Nonplated Hole Features**:
 - a) In the FeatureManager design tree, click **Hole1** .
 - b) Click **Next**.
6. For **Select the Plated Hole Features**:
 - a) In the FeatureManager design tree, click **CirPattern2** .
 - b) In the Task Pane, under **Feature Name**, clear **PTH 2** and **PTH 3**.
 - c) For **PTH**, under **New Name**, type **Seed Hole**.
 - d) Click **Next** until you reach **Finish**.
7. Click **Finish**.

The software exports the board, containing only the selected holes using the renamed instances, into CircuitWorks. The board opens in the CircuitWorks application.

Exporting SOLIDWORKS Features Using the CircuitWorks Export Wizard

You can export selected features from SOLIDWORKS parts into CircuitWorks using the CircuitWorks Export Wizard Task Pane.



To export SOLIDWORKS features using the CircuitWorks Export Wizard:

1. Open `system_dir:\Users\Public\Public Documents\SOLIDWORKS\SOLIDWORKS 2018\samples\whatsnew\circuitworks\BoardFeatures1.sldprt`.
2. In the SOLIDWORKS software, click **Export to CircuitWorks**  (CircuitWorks toolbar) or **CircuitWorks > Export to CircuitWorks**.
3. In the CircuitWorks Export Wizard Task Pane, Select **Top of Board** and click **Next** until you reach **Select the Board Outline**.
4. For **Select the Board Outline**:
 - a) Click **Use the following SOLIDWORKS feature**.
 - b)

When you click on the feature, the software converts the feature name to CircuitWorks-specific name. The old name appears under Selected Feature and the new name appears under **New Name** in the CircuitWorks Task Pane.

In the FeatureManager design tree, select the **Board** and **Chamfer1**  features.

- c) Click **Next**.

5. For **Select the Nonplated Hole Features:**
 - a) In the FeatureManager design tree, select **Hole1** .
 - b) Click **Next**.
6. For **Select the Plated Hole Features:**
 - a) In the FeatureManager design tree, select **Hole2** .
 - b) Continue to click **Next** in the CircuitWorks Export Wizard Task Pane, until you reach **Finish**.
7. Click **Finish**.

The software exports the part into CircuitWorks and opens it in the CircuitWorks application.

Building Model as a Part in CircuitWorks

You can open ECAD files directly in CircuitWorks using an option in the SOLIDWORKS software.

You can open an IDF file directly in CircuitWorks by clicking **File > Open** in SOLIDWORKS. Previously, with this option, you could only build a CircuitWorks file as an assembly in SOLIDWORKS. A new option in CircuitWorks allows you to build a CircuitWorks file as a part in SOLIDWORKS.

To build a model as a part in CircuitWorks:

1. Click **Tools > Add-Ins** to load the CircuitWorks add-in.
2. Click **CircuitWorks Options** (CircuitWorks toolbar) or **Tools > CircuitWorks > CircuitWorks Options**.
3. In the CircuitWorks Options dialog box, on the **General tab**, under **General options**, clear **Open files in CircuitWorks Lite**.
4. Click **File > Open** and navigate to `system_dir:\Users\Public\Public Documents\SOLIDWORKS\SOLIDWORKS 2018\samples\whatsnew\CircuitWorks\BasicBoard.emn`.

The file opens in CircuitWorks.

You can edit any of the board entity properties by right-clicking **Components**, clicking **Properties**, and modifying the **Component Instance Properties**.

5. In the CircuitWorks menu, click **Tools > Build Model as Part**.
6. If a dialog box prompting a warning appears, click **OK**.

The CircuitWorks file is built as a part in SOLIDWORKS.

You can edit the part in SOLIDWORKS and export it back to CircuitWorks by clicking **Tools > CircuitWorks > Export to CircuitWorks**.

Usability Improvements

Controlling CircuitWorks User Options from an Administrator Location Using Windows User Permissions

You can control the CircuitWorks options by setting up the Administrator Options file location in the CircuitWorks Setup Wizard.

To control CircuitWorks user options from an administrator location using Windows User Permissions:

1. Set up CircuitWorks options for users. For details, refer to [Setting Up Administrator Rights](#) on page 69.

An administrator location can be any shared folder where the Options XML file is present. A user can be an administrator or a client depending on his Windows user rights on the shared folder.

2. In SOLIDWORKS, click **CircuitWorks Options** (CircuitWorks toolbar) or **Tools > CircuitWorks > CircuitWorks Options**.
3. In CircuitWorks Options, on the General tab, under **CircuitWorks Setup Wizard**, click **Show Wizard**.
4. In CircuitWorks Setup Wizard, do the following:
 - a) Click **Next**.
 - b) On the **Set Library Location** pane, for **Select Admin XML File**, click **Browse** to specify the location.
5. In the Browse For Folder dialog:
 - a) Navigate to the folder specified in step 4.
 - b) Double-click the file with the name **ecadopt.xml/ecadoptAdmin.xml** or any valid xml options file.

Editing Reference Designators of Multiple Components

You can edit Reference Designators of multiple components simultaneously in SOLIDWORKS.

To edit multiple reference designators:

1. In the SOLIDWORKS software, click **File > Open** and open a CircuitWorks file.
2. On the CircuitWorks tab, right-click a component and click **Edit Reference Designators**.
3. In the Edit Reference Designators dialog box, under **New Reference Designators** column, type the new reference designators for components.
4. Click **Update**.

Setting Up Administrator Rights

You can set up the administrator rights or user rights for CircuitWorks options. You can enable or disable the rights of other users to edit files by providing access to folders for a fully-editable or read-only mode.

To set up administrator rights:

1. In SOLIDWORKS, click **CircuitWorks Options** (CircuitWorks toolbar) or **Tools > CircuitWorks > CircuitWorks Options**.
2. In CircuitWorks Options, in the General tab, do one of the following:
 - Under **Specify Admin file to set CircuitWorks options**, click  to specify the XML file.
 - Under **CircuitWorks Setup Wizard**, click **Show Wizard** and do the following:
 - a. In CircuitWorks Setup Wizard, navigate to **Set Library Location** pane, for **Select Admin XML File**.
 - b. Click **Browse** to specify the location.
3. In the Browse For Folder dialog box:
 - a) Navigate to the file specified in step 3.
 - b) Right-click the file and click **Share with > Specific people** to provide **Read** or **Read/Write** access.

9

SOLIDWORKS Composer

This chapter includes the following topics:

- **SOLIDWORKS Composer**
- **SOLIDWORKS Composer Sync**
- **SOLIDWORKS Composer Player**

SOLIDWORKS Composer

SOLIDWORKS® Composer™ software streamlines the creation of 2D and 3D graphical contents for product communication and technical illustrations.

Label Orientation and Label Position for Measurements

A new section, **Label**, has been created in the **Properties** pane for measurements, to manage the display of measurement labels. It contains two new properties, **Label orientation** and **Label position**.

A few existing properties have been moved to this new **Label** section: **Center value**, **Shape**, **Color**, and **Opacity**. See *Measurement Properties* in the Composer help.

Padding for Measurements

In certain cases, the software applies padding around measurement values to improve legibility.

When the label orientation is set to **Auto**, if a measurement value overlaps the leader line and you set its label's shape to **None**, some padding will be applied around the measurement value to ensure that it remains easy to read.

Support of Favorite Context

When importing 3DXML files that contain 3D Tolerancing & Annotation captures, favorite context is now supported.

The visibility of geometrical elements is properly managed, provided that the favorite context is defined on the annotation set that contains the capture.

Support of Pro/E Creo 3.0

Pro/E Creo 3.0 is now supported.

See *About Supported Import Formats* in the Composer help.

Write Outlines

A new document property is available to configure SMG outputs.

It saves outlines along with the 3D model. Thus, whenever the model is opened, or whenever you change to a render mode that uses outlines, outlines are loaded immediately (as it is no longer required to compute them each time they must be loaded).

See *SMG, SMGXML, SMGPROJ Output* in the Composer help.

Composer files in SMG, SMGXML, and SMGPROJ formats for which outlines are saved now contain a `.smgOutlines` file.

SOLIDWORKS Composer Sync

Support of Favorite Context

When importing 3DXML files that contain 3D Tolerancing & Annotation captures, favorite context is now supported.

The visibility of geometrical elements is properly managed, provided that the favorite context is defined on the annotation set that contains the capture.

Support of Pro/E Creo 3.0

Pro/E Creo 3.0 is now supported.

See *About Supported Import Formats* in the Composer help.

Write Outlines

A new document property is available to configure SMG outputs.

It saves outlines along with the 3D model. Thus, whenever the model is opened, or whenever you change to a render mode that uses outlines, outlines are loaded immediately (as it is no longer required to compute them each time they must be loaded).

See *SMG, SMGXML, SMGPROJ Output* in the Composer help.

Composer files in SMG, SMGXML, and SMGPROJ formats for which outlines are saved now contain a `.smgOutlines` file.

SOLIDWORKS Composer Player

Label Orientation and Label Position for Measurements

A new section, **Label**, has been created in the **Properties** pane for measurements, to manage the display of measurement labels. It contains two new properties, **Label orientation** and **Label position**.

A few existing properties have been moved to this new **Label** section: **Center value**, **Shape**, **Color**, and **Opacity**. See *Measurement Properties* in the Composer help.

Padding for Measurements

In certain cases, the software applies padding around measurement values to improve legibility.

When the label orientation is set to **Auto**, if a measurement value overlaps the leader line and you set its label's shape to **None**, some padding will be applied around the measurement value to ensure that it remains easy to read.

10

SOLIDWORKS Costing

This chapter includes the following topics:



- **Calculating the Cost of Custom Operations for Selected Materials**
- **Costing Template Enhancements**
- **Evaluating the Cost of Assembly Operations**
- **Organizing and Saving Costing Data Locally**

SOLIDWORKS Costing is available in SOLIDWORKS Professional and SOLIDWORKS Premium. Costing for assemblies is available in SOLIDWORKS Premium only.

Calculating the Cost of Custom Operations for Selected Materials

You can define **Material class** for custom operations for selected materials or all materials in the Custom tab of the Costing Template Editor.

To calculate the cost of custom operations for selected materials:

1. Open a sheet metal or machined part.
2. Click **Costing**  (Evaluate tab on the CommandManager) or **Tools > SOLIDWORKS Applications > Costing**.
3. Click **Begin Cost Estimation**.
4. In the Costing Task Pane, click **Launch Template Editor**.
5. On the Custom tab of the Costing Template Editor, for the **Painting** custom operation:
 - a) Click **All** to display the drop-down list.
 - b) Click **Selected**.
 - c) In the dialog box, under **Available Material class**, select **Steel**.
 - d) Click **Add**.
 - e) Click **OK**.
6. Click **Save As** .

7. In the dialog box:
 - a) Navigate to `system_dir:\Program Files\SOLIDWORKS Corp\SOLIDWORKS\lang\english\Costing templates` if it is not your default location.
 - b) For **File name**, type `SteelTemplate`.
 - c) For **Save as type**, select **Template database files (*.sldctm)** for machined parts, and **Template database files (*.sldcts)** for sheet metal parts.
 - d) Click **Save**.
 - e) Click **X**.
8. In the Costing Task Pane:
 - a) Under **Template**, select **SteelTemplate**.
 - b) Under **Material**, select **Steel** for **Class**.



When you select **Always Include**, the calculated cost for the **Painting** custom operation is always included in the CostingManager for **SteelTemplate**.

Costing Template Enhancements

Limited-Access Multibody and Assembly Templates

You can create limited-access templates for multibody parts and assemblies that limit the visibility of certain elements.

In the Costing Template Editor, when you click **Save As Limited Access Copy**, an information message prompts you to click **Yes** or **No**. When you click **Yes**, the template is saved as a limited-access template with the costs visible. When you click **No**, the template is saved as a limited-access template with costs of the following elements hidden:

Element	Sub-Element
Costing DisplayManager 	Show Cost 
	Show Time 
	Tooltips
	Template costs

Element	Sub-Element
Costing Task Pane	Material > Material Cost
	Markup/Discount
	Shop Rate
	Estimated Cost Per Part > Breakdown

The above parameters are also hidden in the Costing report.

Machining and Sheet Metal Template Enhancements

On the Milling tab of machining templates, you can input values for **TER: Tool engagement ratio** under **TER (%)**. On the Cut tab of sheet metal templates, you can input values in **Unit** for the **Cut Type** of **Length**.

You can assign three types of **Unit**, for the **Cut Type** of **Length**:

- USD/mm
- USD/cm
- USD/m

These options allow you to choose the area and cost per unit for Costing.

Evaluating the Cost of Assembly Operations



You can assign assembly operation costs in the template. You can override template costs, and add assembly operation time in the PropertyManager.

To evaluate the cost of assembly operations:

1. Open system_dir:\Users\Public\Public Documents\SOLIDWORKS\SOLIDWORKS 2018\samples\whatsnew\costing\Conveyor\Conveyor.sldasm.
2. Click **Costing**  (Evaluate tab on the CommandManager) or **Tools > SOLIDWORKS Applications > Costing**.
3. In the CostingManager, right-click **Assembly Operations** and click **Add Assembly Operation**.
4. In the Assembly Operations PropertyManager, under **Name**, type **Fastening**.
5. In the PropertyManager, click **Each selected component**, and **Ctrl +** select four fasteners of a corner in the graphics area.

6. In the PropertyManager, do the following:
 - a) Under **Operation Time**, type 10.
 - b)



The default value is 60 USD/hr.

Under **Assembly Operation Cost**, type 20.
 - c) Click .
7. In the CostingManager, right-click **Assembly Operations** and click **Add Assembly Operation**.
8. In the Assembly Operations PropertyManager, under **Name**, type **Inspection**.
9. In the PropertyManager, click **Entire selection**, and select the entire assembly in the graphics area.
10. In the PropertyManager, do the following:
 - a) Under **Operation Time**, type 3600.
 - b) Under **Assembly Operation Cost**, type 100.
 - c) Click .
11. In the Costing Task Pane, click **Begin Cost Estimation**.

Organizing and Saving Costing Data Locally

You can save Costing data. Such data includes CAD files, Costing templates, and Costing reports locally as a package, with the **Costing Pack and Go** tool.

To organize and save Costing data locally:



1. Open an assembly.
2. Click **Costing**  (Evaluate tab on the CommandManager) or **Tools > SOLIDWORKS Applications > Costing**.
3. Click **Begin Cost Estimation**.
4. In the Costing Task Pane, click **Generate Report** .
5. In the Report Options dialog box, choose the report options and click **Publish**.
6. In the Costing Task Pane, click **Costing Pack and Go** .

If a warning message prompts you to save the assembly, click **OK** and save the assembly.

7. In the Costing Pack and Go dialog box:

- a) The default file name is the same as the CAD file name. You can rename the file name.

For **File name**, type a name.

- b) For **Save to**, click  and browse to the location where you want to save the report.
- c) Select **Include Costing report** and click  to browse to the location of the report to include.
- d) Click **Save**.

11

DimXpert

This chapter includes the following topics:

- **3D PMI Compare for DimXpert Annotations Is Enhanced**
- **Automatic Generation of DimXpert Annotations for Fastener Assemblies**
- **Customizable General Tolerances for DimXpert**
- **Displaying Component-level DimXpert Annotations in Assemblies**
- **General Profile Tolerance**
- **Patterned Datums**

3D PMI Compare for DimXpert Annotations Is Enhanced

When using the **3D PMI Compare** tool, the restriction that the modified part starts as a copy of the reference part is removed. You can apply DimXpert to each model independently. There is an assumption that the face IDs of the parts are consistent.

Automatic Generation of DimXpert Annotations for Fastener Assemblies

You can use DimXpert to automatically annotate one of the two components of a fixed or floating fastener assembly.

Starting with the source component, its annotations are used to create the annotations on the target component using the fixed and floating fastener formulas, as outlined in ASME Y14.5, to compute the necessary tolerances.

To use DimXpert to automatically annotate one of the two components of a fixed or floating fastener assembly:

1. Click **Tools > DimXpert > Auto Pair Tolerance**.

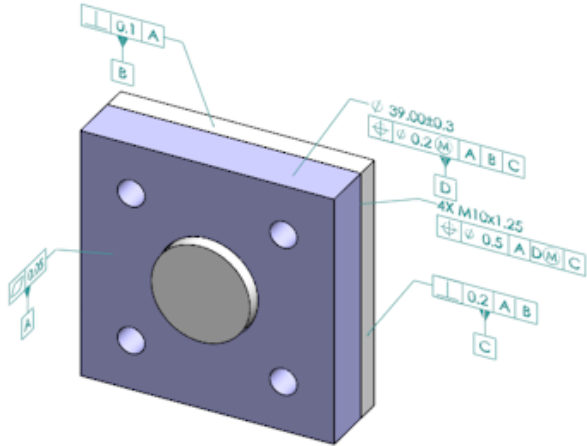

2. In **Source**, select the source component (red arrow).
3. In **Target**, select the target component (black arrow).

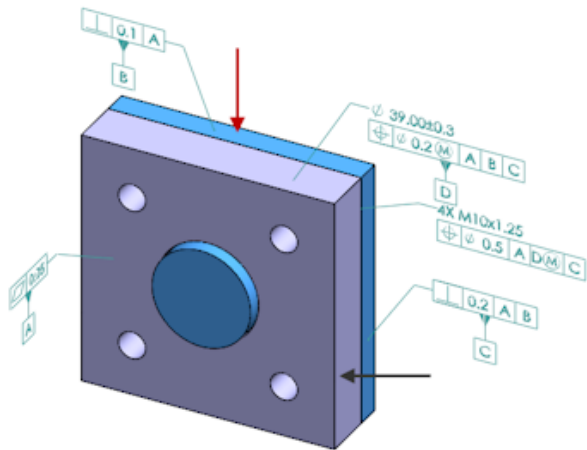

4. Click .

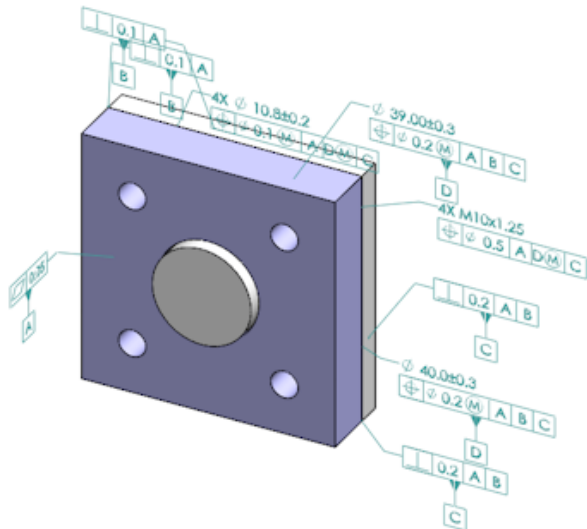

Customizable General Tolerances for DimXpert

You can view the general tolerance file used in DimXpert and TolAnalyst and customize it to conform to your specific design requirements.

To specify the folder for DimXpert general tolerance file, click **Tools > Options > System Options > File Locations**. Under **Show folder for**, select **DimXpert General Tolerance File** and click **OK**.

Default general tolerance file:

Linear										
Designation	Description	from	over	over	over	over	over	over	over	over
		0	3	6	30	120	400	1000	2000	4000
		up to	up to	up to	up to	up to	up to	up to	up to	up to
		3	6	30	120	400	1000	2000	4000	∞
C1	Custom1	0.1	0.1	0.2	0.3	0.5	0.8	1.2	2	3
C2	Custom2	0.05	0.1	0.3	0.5	0.8	1	1.5	3	4

Broken Edge				
Designation	Description	from	over	over
		0	3	6
		up to	up to	up to
		3	6	∞
C1	Custom1	0.1	0.5	1
C2	Custom2	0.2	0.8	2

Angular						
Designation	Description	from	over	over	over	over
		0	10	50	120	400
		up to	up to	up to	up to	up to
		10	50	120	400	∞
C1	Custom1	0.1	0.1	0.2	0.3	0.4
C2	Custom2	0.05	0.1	0.3	0.5	0.7

Units	
Linear	mm
Angular	Degrees

Customizing the General Tolerance File

You can customize the general tolerance file used in DimXpert to conform to your specific design requirements.

To customize the general tolerance file:

1. In the folder specified in **System Options > File Locations > DimXpert General Tolerance File**, use Microsoft Excel to open `general_tolerances.xlsx`.

The file contains the following sections:

Linear	Specifies ranges and tolerances for linear dimensions.
Broken Edge	Specifies ranges and tolerances for chamfer and fillet dimensions.
Angular	Specifies ranges and tolerances for angular dimensions.
Units	Specifies the units of measure for linear and angular values in the table.

2. Under **Units**, set the units of measure for values in the table.
If you use the general tolerance file in a model that uses different units, the values are automatically converted to match the model's units.

3. Customize values in the file.

For example:

- a) To modify
- Custom1**
- for linear dimensions, locate the
- Linear**
- section.

Linear					
Designation	Description	from	over	over	over
		0	3	6	30
		up to	up to	up to	up to
		3	6	30	120
C1	Custom1	0.1	0.1	0.2	0.3
C2	Custom2	0.05	0.1	0.3	0.5

- b) Change the values in the
- Custom1**
- row.

For example, to change the tolerance from 0.2 to 0.3 for linear dimensions that are in the range over 6 and up to 30, you change the corresponding **Custom1** value from 0.2 to 0.3.

over
6
up to
30
0.2
0.3

← →

over
6
up to
30
0.3
0.3

Formatting in the general tolerance file must be maintained. If you change formatting, the file is not recognized as valid, and default values are used instead. For example, do not rearrange cells or leave cells blank.

4. Save the Microsoft Excel file.

You must load the general tolerance file every time you update values in it or change its location.

5. To load the file:

- a) Click **Tools > Options > Document Properties > DimXpert**.
- b) Under **General tolerance**, for **Tolerance class**, select a custom class.
- c) Click **Load Custom**, and then click **OK** to confirm your selection.

Using a Customized General Tolerance File

In DimXpert, when you use the **General Tolerance** method, you can use the general tolerance file that you have customized for your specific design requirements.

To use a customized general tolerance file:

1. Click **Options**  (Standard toolbar) or **Tools > Options**.
2. On the Document Properties tab, click **DimXpert**.

3. Under **Methods**, select **General Tolerance**.

Options in the **General tolerance** section are enabled. The following options are available for **Tolerance class**:

- Four non-customizable options (**Fine, Medium, Coarse, Very Coarse**) based on *ISO 2768-1*.
- Two customizable options (**Custom1** and **Custom2**) defined in the custom general tolerance file (`general_tolerances.xlsx`).

4. For **Tolerance class**:

- a) Select **Custom1** or **Custom2**.
- b) Click **Load Custom** to load the custom values.

Later, if you make changes to the general tolerance file or change the file location, return to this dialog box and click **Load Custom** again.

5. Click **OK** to confirm that you want to load the values.
6. Click **OK**.

To use **Custom1** or **Custom2** as the default tolerance class in new models, edit your existing document template or create a new document template.

Otherwise, every time you create a new model, you need to click **Tools > Options > Document Properties > DimXpert**, select **Custom1** or **Custom2**, and click **Load Custom**.

Inserting a General Tolerance Table

You can insert a table in a model to display the current general tolerances in use.

To insert a general tolerance table:

1. Click **Insert > Tables > General Tolerance**.
2. In the PropertyManager, set the options.
3. Click .
4. Click in the graphics area to place the table.

Displaying Component-level DimXpert Annotations in Assemblies

To display component-level DimXpert annotations in an assembly, click **Tools > Options > Document Properties > Detailing** and select **Show DimXpert when viewing component annotations**.

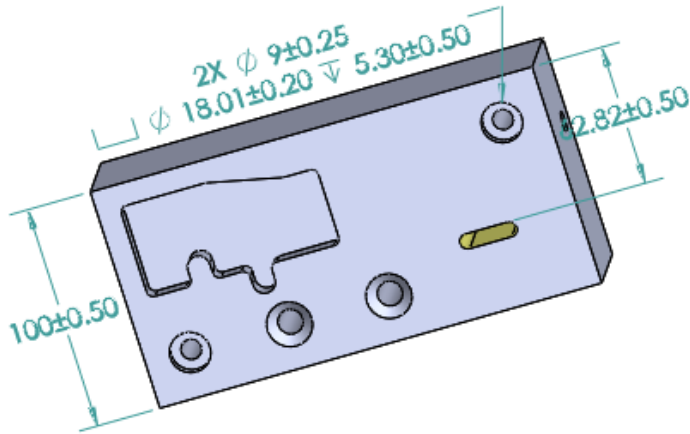

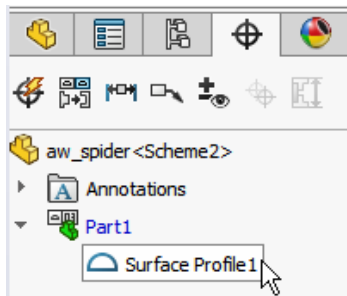

General Profile Tolerance

General all over profile tolerance is available to let you fully define models using a single profile tolerance feature control frame. You can insert a general profile tolerance in a note or table cell.



Inserting a General Profile Tolerance in a Note

To insert a general profile tolerance in a note:

1. Click **Insert** > **Annotations** > **Note**.
2. In the graphics area, click to place the note.
3. In the PropertyManager, under **Text Format**, select **Insert DimXpert General Profile Tolerance** .
4. Set the options.
5. Click .

Editing a Geometric Profile Tolerance

After creating a geometric profile tolerance, you can modify it using the Geometric Tolerance Properties dialog box.

To edit a geometric profile tolerance:

1. In the DimXpertManager, right-click the geometric profile tolerance feature and click **Edit General Profile Tolerance**. In this example, right-click **Surface Profile 1**.

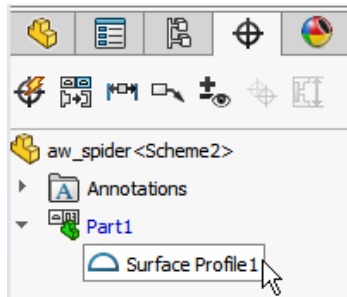

2. In the Properties dialog box, select the geometric tolerance options.
3. Click **OK**.

Patterned Datums

You can assign datums to hole patterns, concentric holes with gaps between them, width patterns, and concentric bosses. You can create datums as individual features or patterns using counterbores and countersinks.

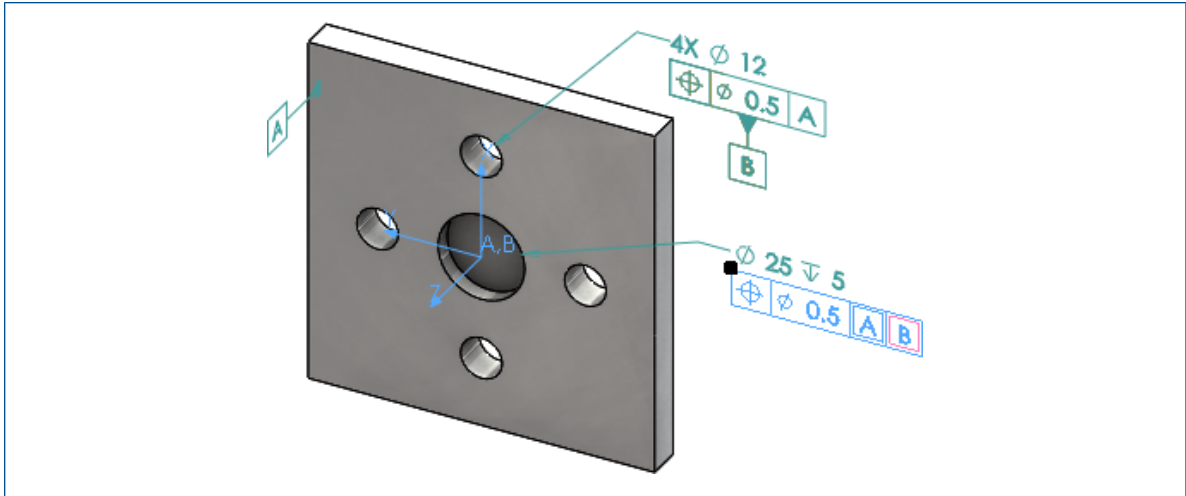

Four-hole pattern used as secondary datum

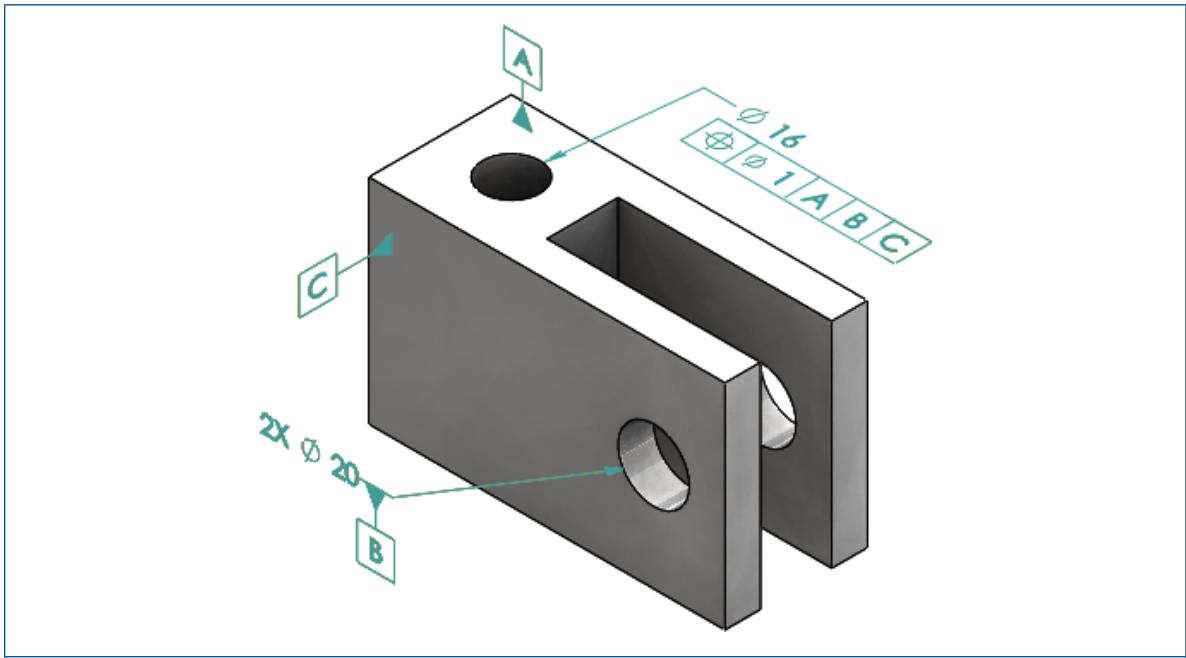

Two concentric hole pattern used as secondary datum

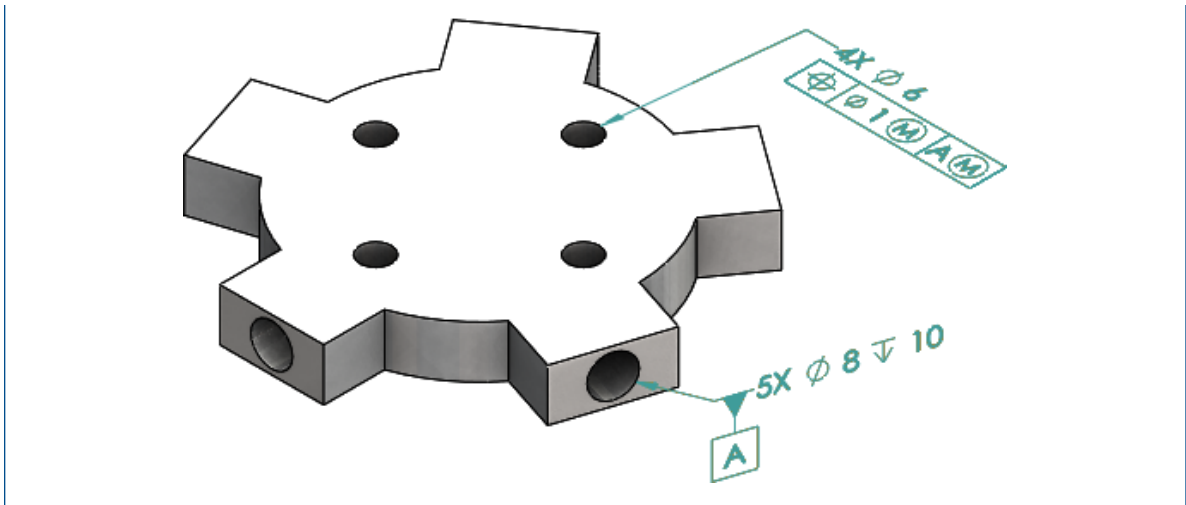

Five-hole radial pattern used as primary datum

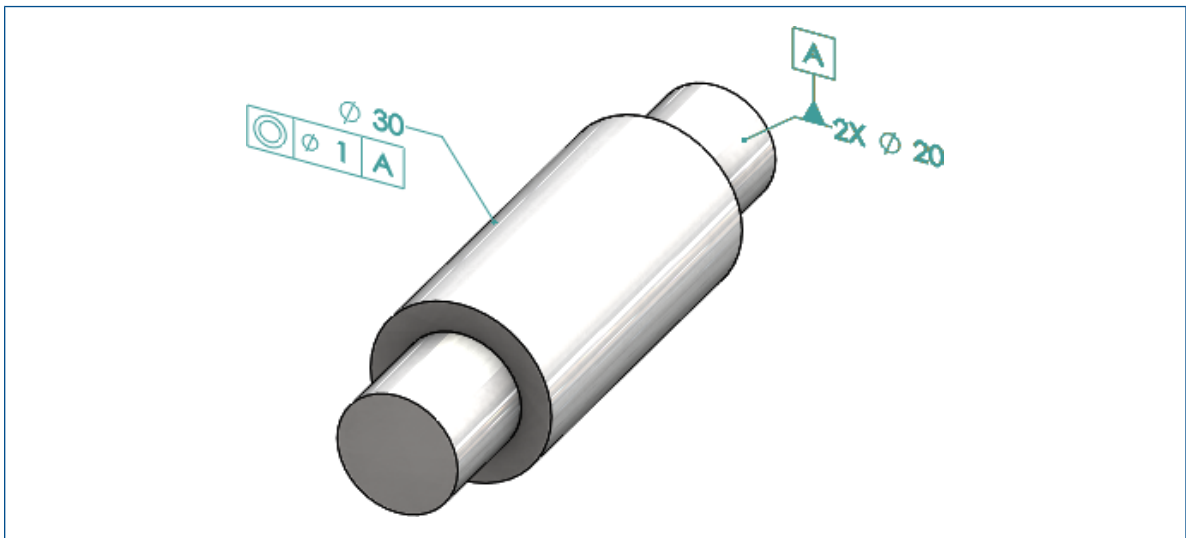

Two boss features used to define datum A

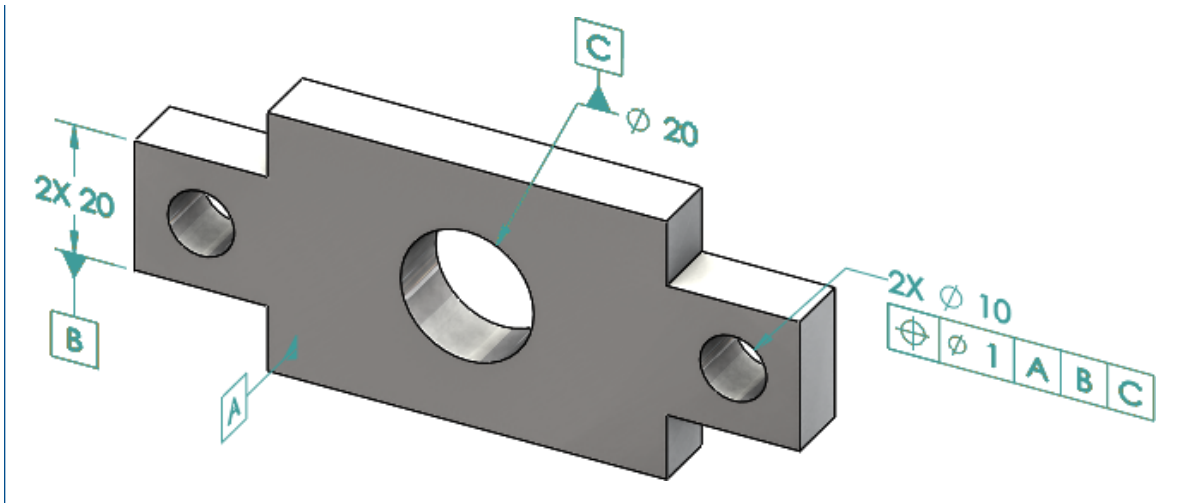

Two width features used to define datum B

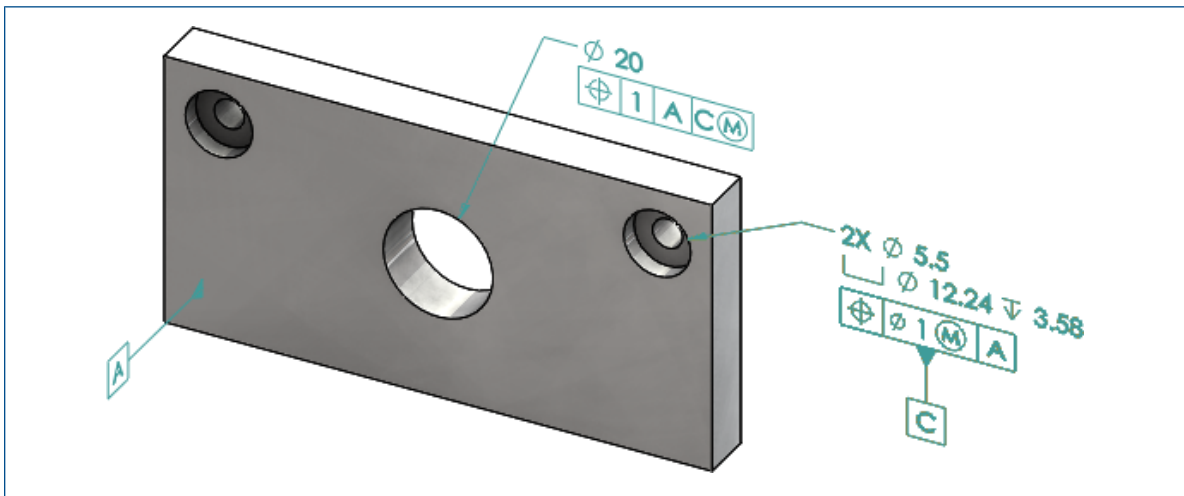

Two counterbore holes used to define datum C

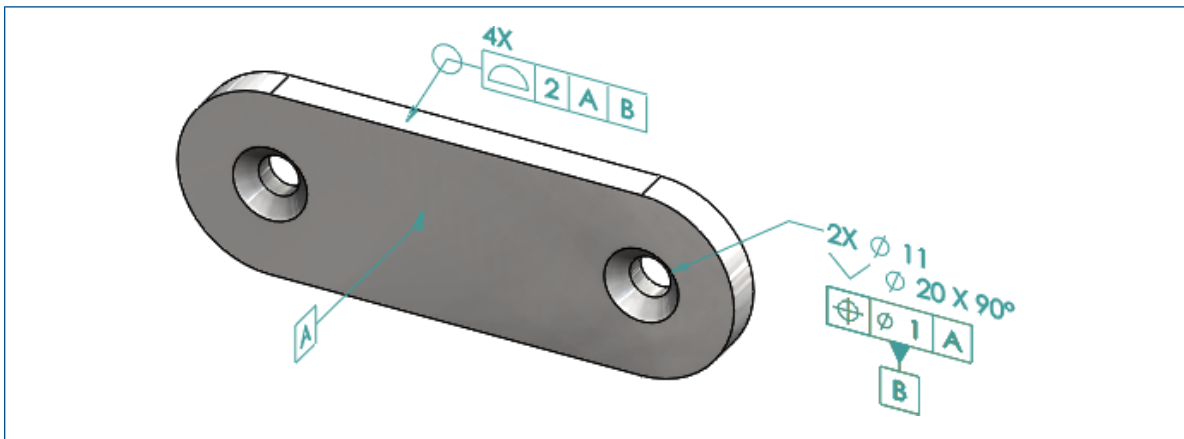

Two countersink holes used to define datum B

12

Detailing and Drawings

This chapter includes the following topics:



- **Annotations**
- **Dimensions**
- **Drawing Views**
- **Output**
- **Tables**

Annotations

Auto Hatching in Section Views

Auto hatching in section views and broken-out section views has a new option.

Randomize scale Randomizes the hatch scale for the same material in the drawing view. Clear this setting to keep the scale identical for all hatches of multiple parts of the same material.

1. In a drawing, click **Insert > Drawing View > Section**.
2. In the Section View Assist PropertyManager, set the options.
3. Click .
4. In the Section View PropertyManager, under **Section View**, select **Auto hatching**.
5. Select or clear **Randomize scale**.
6. Set the options.
7. Click .

Custom Property Improvement

In annotations and tables, you can create or reference a File property or Cut list property with the correct evaluated value when it contains quotes in its expression name.

Movable Datum Target

You can create movable datum targets with the Datum Target tool.

The options include:

- Horizontal movable
- Rotational movable

Horizontal Movable

Horizontal Movable  creates a movable datum target where the movable symbol is always pointing either left or right with an arrow that can extend in any direction.

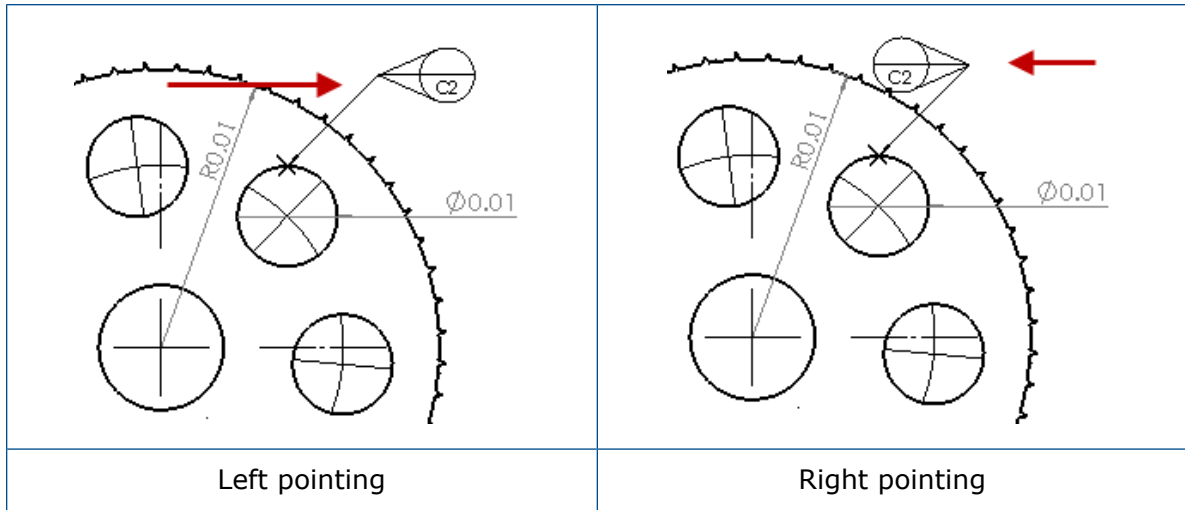

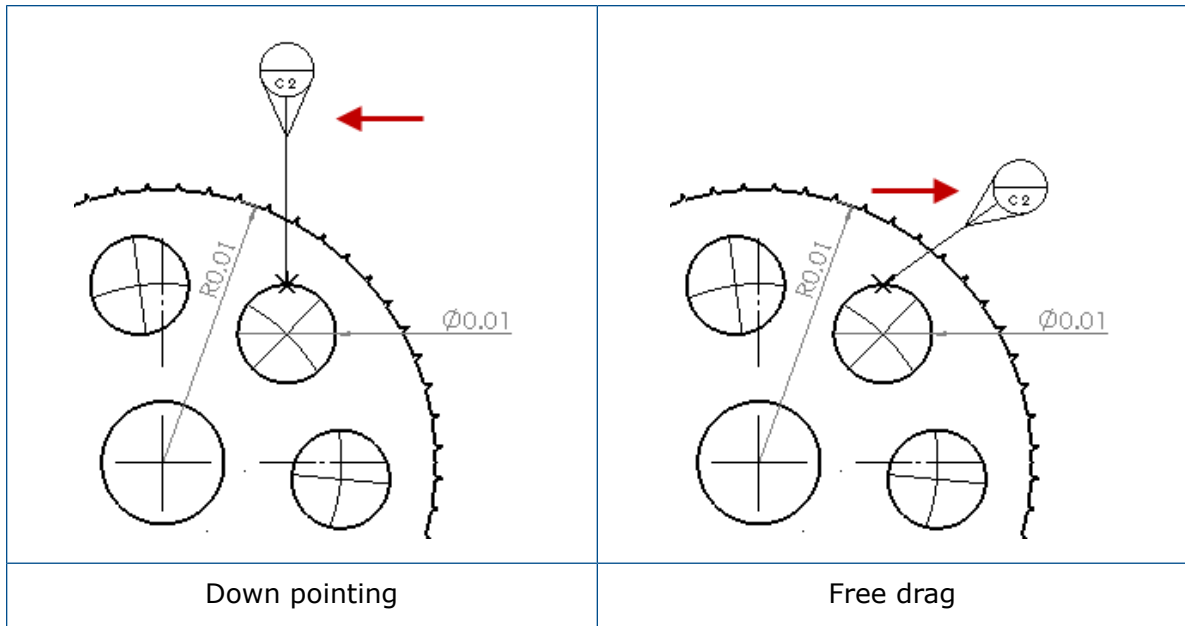

Rotational Movable

Rotational Movable  creates a movable datum target where the movable symbol always points directly at the datum target center. You can choose **Up**, **Down**, **Left**, **Right**, **Free Drag**, or **By Selection**.



Creating a Horizontal Movable Datum Target

To create a horizontal movable datum target:



1. Click **Datum Target**  (Annotation toolbar), or click **Insert > Annotations > Datum Target**.
2. In the PropertyManager, under **Settings**, select **Horizontal Movable** .
3. Click in the graphics area to place the target. You can drag the pointer left or right to change the direction of the symbol before clicking again to place the symbol.
4. Click to place the symbol.

You cannot select other options in the PropertyManager until you place the symbol. To set other options, such as **Lock Leader Angle** to drag the circle along the angle specified in **Angle** only, you must reselect the datum target and set the options in the PropertyManager.

5. Click .

Creating a Rotational Movable Datum Target

To create a rotational movable datum target:

1. Click **Datum Target**  (Annotation toolbar), or click **Insert > Annotations > Datum Target**.
2. In the PropertyManager, under **Settings**, select **Rotational Movable** .
3. Click in the graphics area to place the target. You can freely drag the pointer to any angle before clicking again to place the symbol.

- Click to place the symbol.

You cannot select other options in the PropertyManager until you place the symbol. To set other options, such as **Left**, **Right**, **Up**, **Down**, **Free Drag**, or **By Selection**, you must reselect the datum target and set the options in the PropertyManager.

- Click .

New Draft Symbols

Draft is a new category in the Symbol Library.

The draft symbols include:

Symbol	Description
+DFT	Plus Draft
-DFT	Minus Draft
	Parting Line Diamond
	Parting Line
DFTINCL	Tolerance Draft

New Geometric Tolerance Options

Per ASME Y14.8 requirements, two new geometric tolerance options are available, **All Over This Side** and **All Around This Side**.

To access the options, click **Insert** > **Annotations** > **Geometric Tolerance**. In the PropertyManager, under **Leader**, select **All Over This Side**  or **All Around This Side** .

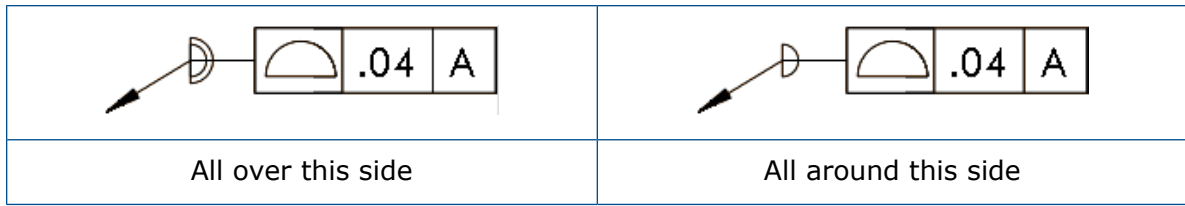

These options are available in drawings, parts, and assemblies, but not in DimXpert.

Dimensions

Hole Callouts Supported in Advanced Hole Tool

You can create hole callouts for holes created with the **Advanced Hole** tool.

You can reverse the callout order. In the Dimension PropertyManager, under **Dimension Text**, select **Reverse Callout Order**. You may need to reverse the callout order when you place a callout on the far side face.

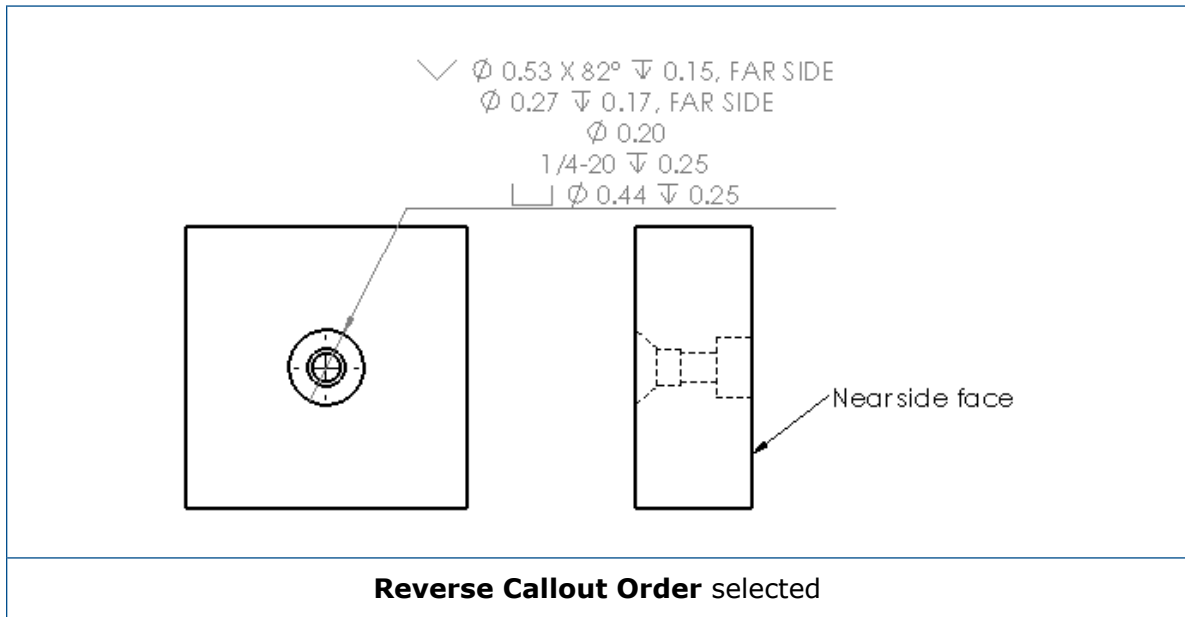

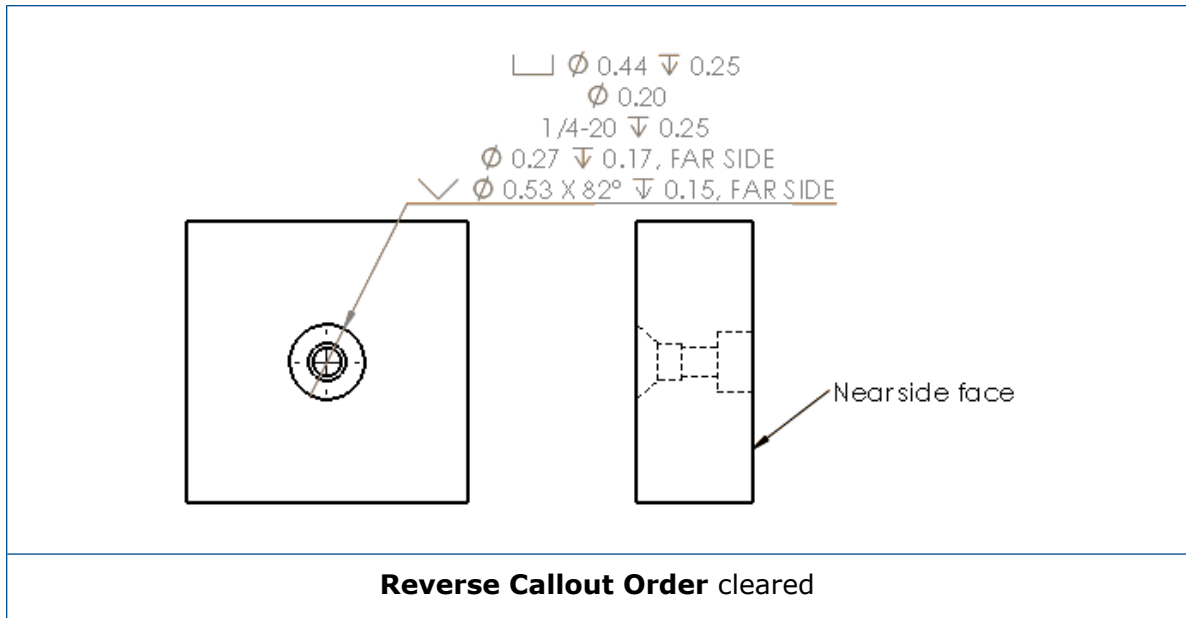

You can define the callout in the feature by including additional text. In the Dimension PropertyManager, under **Dimension Text**, type the text to include in **Text Above**, and **Text Below**.

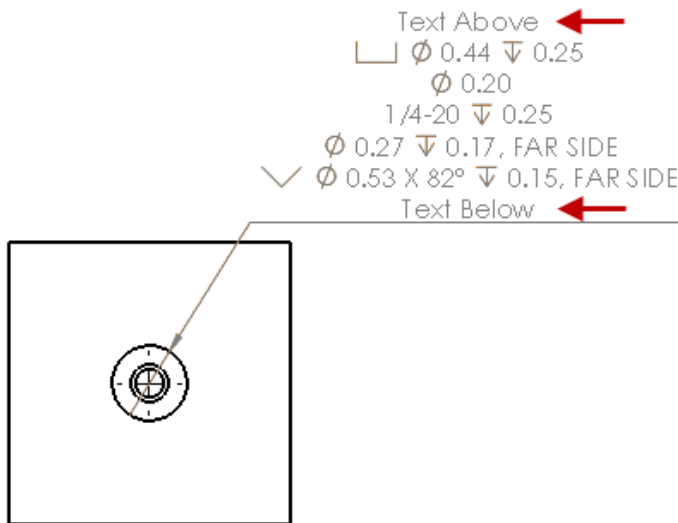

Trailing Zeroes

New options in the Options dialog box let you control individual values for trailing zeroes in dimensions, tolerances, and property values.

The legacy options **Smart** and **Standard** for trailing zeroes are no longer available for documents created in SOLIDWORKS 2018 and later. Documents created in SOLIDWORKS 2017 and earlier retain these settings with legacy behavior if they are used.

Setting Trailing Zeroes in Dimensions

To set trailing zeroes in dimensions:

1. Click **Tools > Options > Document Properties > Dimensions**.
2. In **Zeroes**, under **Trailing zeroes**, in **Dimensions**, select:

<p>Smart</p>	<p>To maintain trailing zero behavior from SOLIDWORKS 2017 for dimensions, tolerances, and properties.</p> <p>When Smart is selected, Tolerances and Properties are not available for selection.</p>
<p>Show</p>	<p>To display trailing zeroes up to the number of decimal places applied to each dimension.</p> <p>When Show is selected, Tolerances and Properties are available for selection.</p>
<p>Remove</p>	<p>To remove trailing zeroes from each dimension.</p> <p>When Remove is selected, Tolerances and Properties are not available for selection.</p>
<p>Standard</p>	<p>When Standard is selected, trailing zeros behavior for dimensions, tolerances, and properties appear according to the overall drafting standard. This selection is available for parts, assemblies, and drawings created prior to SOLIDWORKS 2018.</p> <p>When Standard is selected, Tolerances and Properties are not available for selection.</p>

3. Click **OK**.

Setting Trailing Zeroes in Properties

This setting applies to each numeric property value on the **Units** page of **Document Properties** such as Mass, Density, Volume, Surface Area, Cost, Center of Mass, and Block Tolerance.

This setting also applies to numeric property values that are displayed in the graphics area or are evaluated in custom properties or other annotations such as notes and tables.

To set trailing zeroes in properties:

1. Click **Tools > Options > Document Properties > Dimensions**.
2. In **Zeroes**, under **Trailing zeroes in Dimensions**, select **Show**.
3. In **Properties**, select:

Show	To display trailing zeroes up to the number of decimal places applied to each numeric property from the Units page of Document Properties as well as displayed numeric properties in the graphics area or are evaluated in custom properties or other annotations such as notes and tables.
Remove	To remove trailing zeroes from each numeric property value.

4. Click **OK**.

Setting Trailing Zeroes in Tolerances

This setting applies to tolerance values for Arc Length, Chamfer, Diameter, Hole Callout, Linear, Ordinate, Radius, as well as the display of tolerance values that appear within other annotations such as notes and tables.

To set trailing zeroes in tolerances:

1. Click **Tools > Options > Document Properties > Dimensions**.
2. In **Zeroes**, under **Trailing zeroes in Dimensions**, select **Show**.

3. In **Tolerances**, select:

Show	To display trailing zeroes up to the number of decimal places applied to each tolerance within the dimension (Bilateral, Limit, and symmetric).
Remove	To remove trailing zeroes from each tolerance (Bilateral, Limit, and symmetric).
Remove only on zero	To remove trailing zeroes from each tolerance when the displayed value is zero. Also, when the value of the displayed tolerance is not equal to zero, trailing zeroes are displayed up to the number of decimal places that apply to each tolerance in the dimension.

4. Click **OK**.

Drawing Views

Applying Layers and Colors to Hatches

You can apply hatches to specific layers. When you apply a hatch to a specific layer, the hatch inherits the show/hide, print on/off, and color properties of the layer.

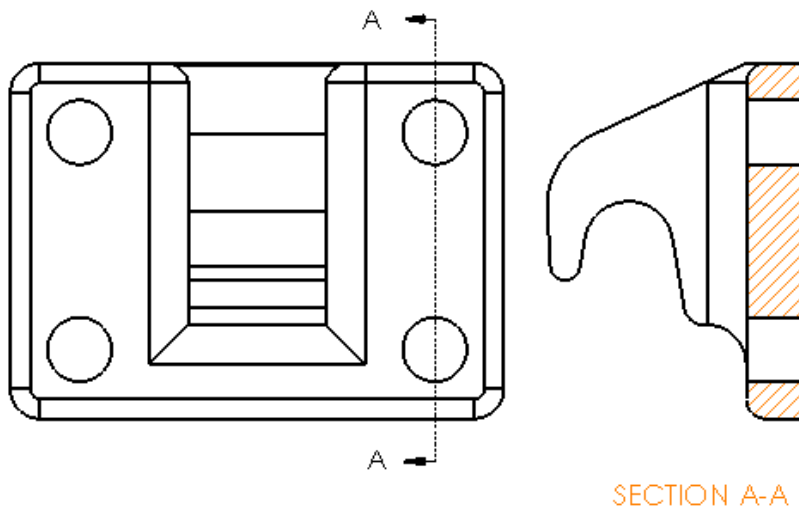

To apply a hatch to a specific layer:

1. In the graphics area, select the hatch.
2. In the Area Hatch/Fill PropertyManager, under **Layer**, select the layer.

3. Click .

Blocks in Break Views

You can choose whether or not to clip sketch blocks in break views.

In a break view, in the Break View PropertyManager under **Break View Settings**:

- Select **Break sketch blocks** to clip the sketch blocks.
- Clear **Break sketch blocks** to display the sketch blocks with no clipping.

For example:

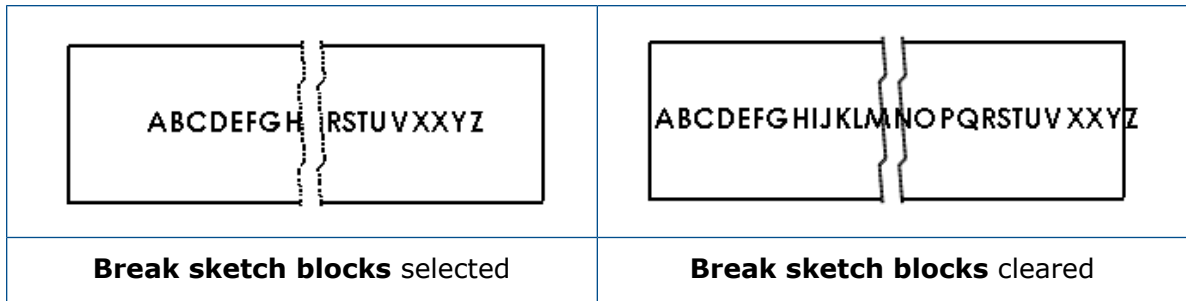

Broken-Out Section Views

Broken-Out Section View on Alternate Position View

You can add broken-out section views to alternate position views.

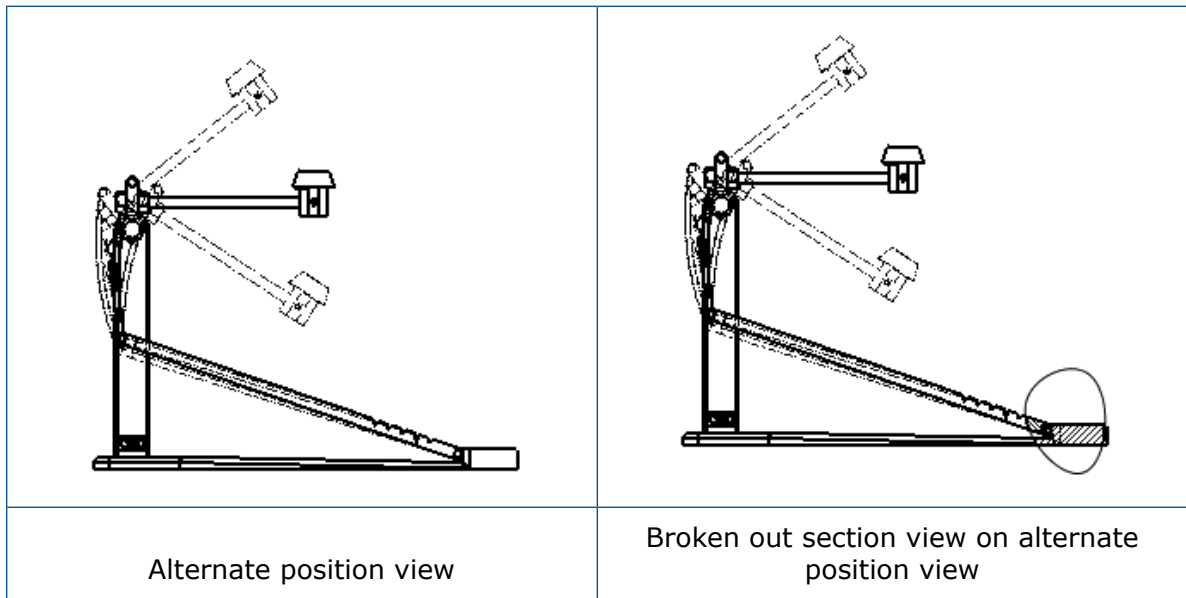

To add a broken-out section view to an alternate position view:

1. In an alternate position view, click **Insert** > **Drawing View** > **Broken-out Section**.

Broken-out sections can only cut the reference configuration of the drawing view, not the alternate positions.

2. Sketch a closed profile such as a spline.
3. In the PropertyManager, set options.
4. Click .

Broken-Out Section View on Detail View

You can add broken-out section views to detail views.

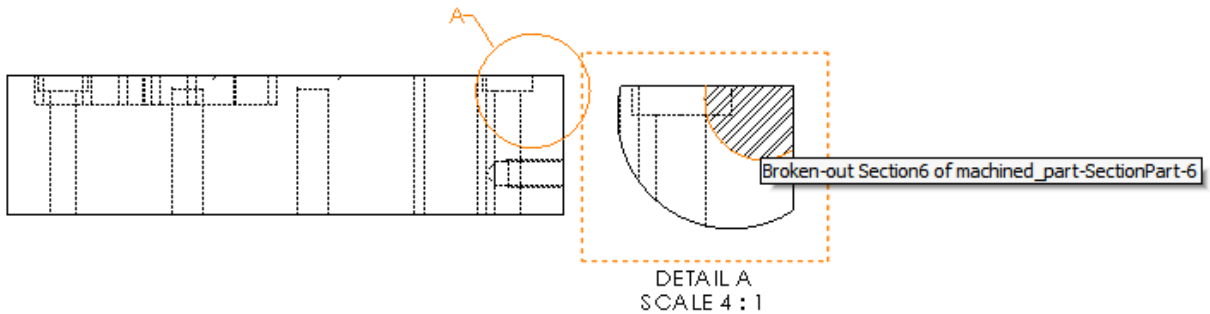

To add a broken-out section view to a detail view:

1. In a detail view, click **Insert** > **Drawing View** > **Broken-out Section**.
2. Sketch a closed profile such as a spline.
3. In the PropertyManager, set options.
4. Click .

Broken-Out Section View on Section View

You can add broken-out section views to section views.

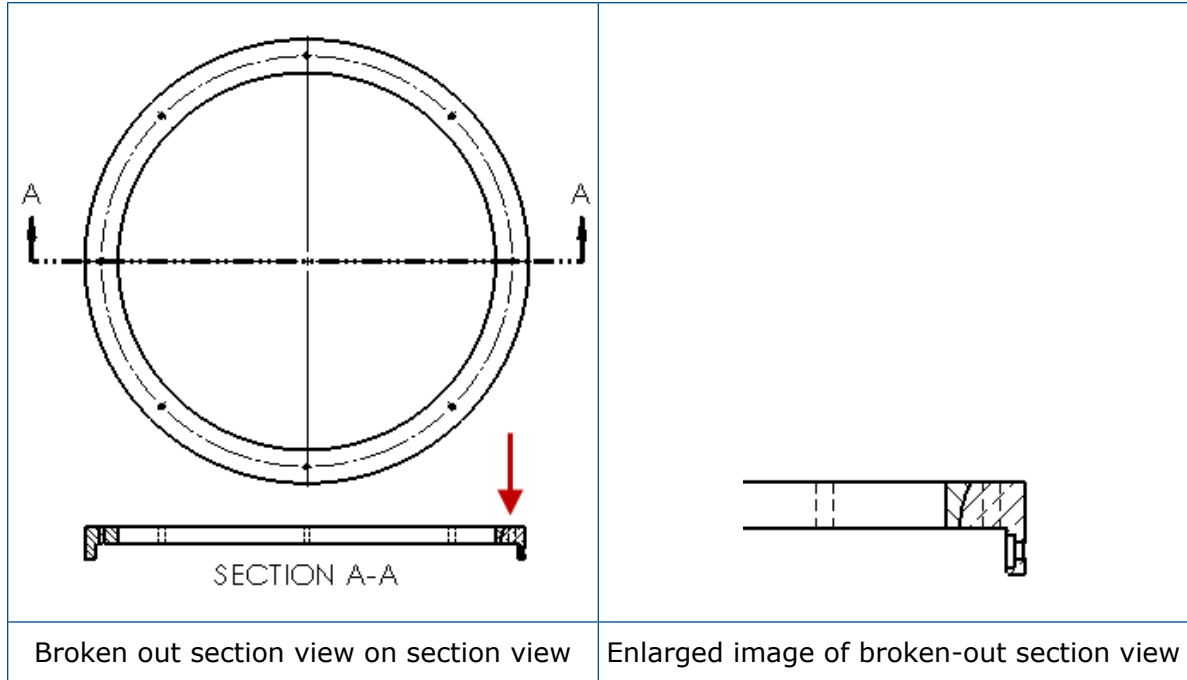

To add a broken-out section view to a section view:

1. In a section view, click **Insert** > **Drawing View** > **Broken-out Section**.
2. Sketch a closed profile such as a spline.

3. In the PropertyManager, set options.
4. Click .

Inserting a 3D View in a Drawing

If you create 3D views in SOLIDWORKS MBD, you can insert them in drawing views. In addition, you can insert any annotations that you create in the 3D view if they are orthogonal to the drawing view.

To insert a 3D view in a drawing:

1. In SOLIDWORKS MBD, create a 3D view.
2. In the drawing view, on the View Palette, select the 3D view.
3. Drag the 3D view to the drawing sheet and release.
4. Optionally, in the Drawing View PropertyManager, under **Import options**, select **Import annotations** and **3D View annotations**.
5. Click .

Output

Bookmarks in PDF Output

You can choose to include or exclude bookmarks when you save a drawing as PDF.

Click **Tools** > **Options** > **System Options** > **Export**. In **File Format**, select **PDF**. Select **Include bookmarks** to include bookmarks in the PDF output. Clear **Include bookmarks** to exclude bookmarks in the PDF output.

Tables

All Uppercase Characters

You can specify all characters in a table to be uppercase.

Click **Tools** > **Options** > **Document Properties** > **Drafting Standard**. Under **Uppercase**, select **All uppercase for tables** to apply uppercase characters to all table entries in any table type.

In SOLIDWORKS 2018, the option **All uppercase** is renamed to **All uppercase for notes**, which continues to control uppercase characters for all notes.

To specify all characters in a table cell to be uppercase, select a cell and on the table editing toolbar, click **All uppercase** . Optionally, in the Table PropertyManager, under **Text Format**, select or clear **All uppercase**.

Revision Table Driven By SOLIDWORKS PDM

You can use SOLIDWORKS PDM to drive a revision table.

When you manage a revision table from SOLIDWORKS PDM, in **Options > Document Properties > Tables > Revisions**:

- **Alpha/numerical control** is disabled and **Revision driven from SOLIDWORKS PDM** is displayed.
- Under **Multiple sheet style**, **Independent** is disabled and **Independent type Revision Table is not supported while revision is driven from SOLIDWORKS PDM** is displayed.

For more information, see the *SOLIDWORKS PDM* chapter in this document.

13

eDrawings

This chapter includes the following topics:

- **3D Views**
- **Decals in eDrawings Files**
- **Setting Options and Passwords for eDrawings Files**
- **STEP Files in eDrawings Files**
- **User Interface Enhancements**
- **Zooming In and Out**

eDrawings® Professional is available in SOLIDWORKS Professional and SOLIDWORKS Premium.

3D Views

You can display all of the 3D Views associated with a model.

In the 3D Views pane, click **Show All** to display all of the 3D Views associated with the model. Otherwise, only the 3D Views associated with the active configuration are displayed.

The **Show All** functionality is available for models saved in SOLIDWORKS 2018 and later.

Decals in eDrawings Files

You can include decals in published eDrawings files.

Previously, eDrawings only displayed stock decals and decals whose image data was in a separate file, such as `.png` or `.jpg`, on your computer.

To include decals in published eDrawings files, in the SOLIDWORKS software, click **Tools** > **Options** > **Document Properties** > **Model Display** and select **Store appearance, decal, and scene data in model file**.

Setting Options and Passwords for eDrawings Files

When you save or publish a file as an eDrawings file, the options and password settings are streamlined.

When you save or publish an eDrawings file, the **Options** and **Password** buttons are no longer in the Save As dialog box. Instead, the Save Configurations to eDrawings file or Save Sheets to eDrawings file dialog box appears with the **Options** and **Password** buttons.

To set options and passwords for eDrawings files:

1. In the SOLIDWORKS software, click **Save As**  or **File > Save As**.
2. In the Save As dialog box, in **Save as type**, select **eDrawings** and click **Save**.
3. In the Save Configurations to eDrawings file or Save Sheets to eDrawings file dialog box, click **Options** or **Password** to access settings.

You can also click **Publish to eDrawings**  or **File > Publish to eDrawings** to access these dialog boxes.

STEP Files in eDrawings Files

When you save or publish an eDrawings file, you can attach STEP files to each configuration of the eDrawings file. By attaching STEP files, you include the model geometry associated with the eDrawings file.

Attaching STEP Files to eDrawings Files



You can attach STEP files to parts and assemblies.

To attach STEP files to eDrawings files:

1. In the SOLIDWORKS software, click **Save As**  (Standard toolbar) or **File > Save As**.

You can also click **Publish eDrawings File**  (Standard toolbar) or **File > Publish to eDrawings**.

2. In the Save As dialog box, in **Save as type**, select **eDrawings** and click **Save**.

3. In the Save Configurations to eDrawings file dialog box:
 - a) In the  column, select at least one configuration to save.
 - b) In the  column, select the STEP files to save.
You can include a STEP attachment for any of the available configurations in the file. Including a STEP attachment is independent of including the eDrawings data for each configuration as long as you select at least one configuration for publishing the eDrawings data.
 - c) In **Create and attach STEP file of type**, select the type of STEP file to attach. Supported STEP formats are STEP AP203 and STEP AP214. If you have a SOLIDWORKS MBD license, you can also attach STEP AP242 files, which support Product and Manufacturing Information (PMI).
 - d) Click **OK**.

Opening STEP Files in eDrawings

To open STEP files in eDrawings:

1. In eDrawings, open a part or assembly document that has a STEP attachment.
2. Click **Attachments** .
3. In the Attachments pane:
 - a) Select an attachment to open.
 - b) Click one of the following:



View Attachment

Opens the STEP file in eDrawings. An attachment icon  appears in the tab with the file name.



Extract Attachment

Saves the STEP file to a location you choose.





Delete Attachment

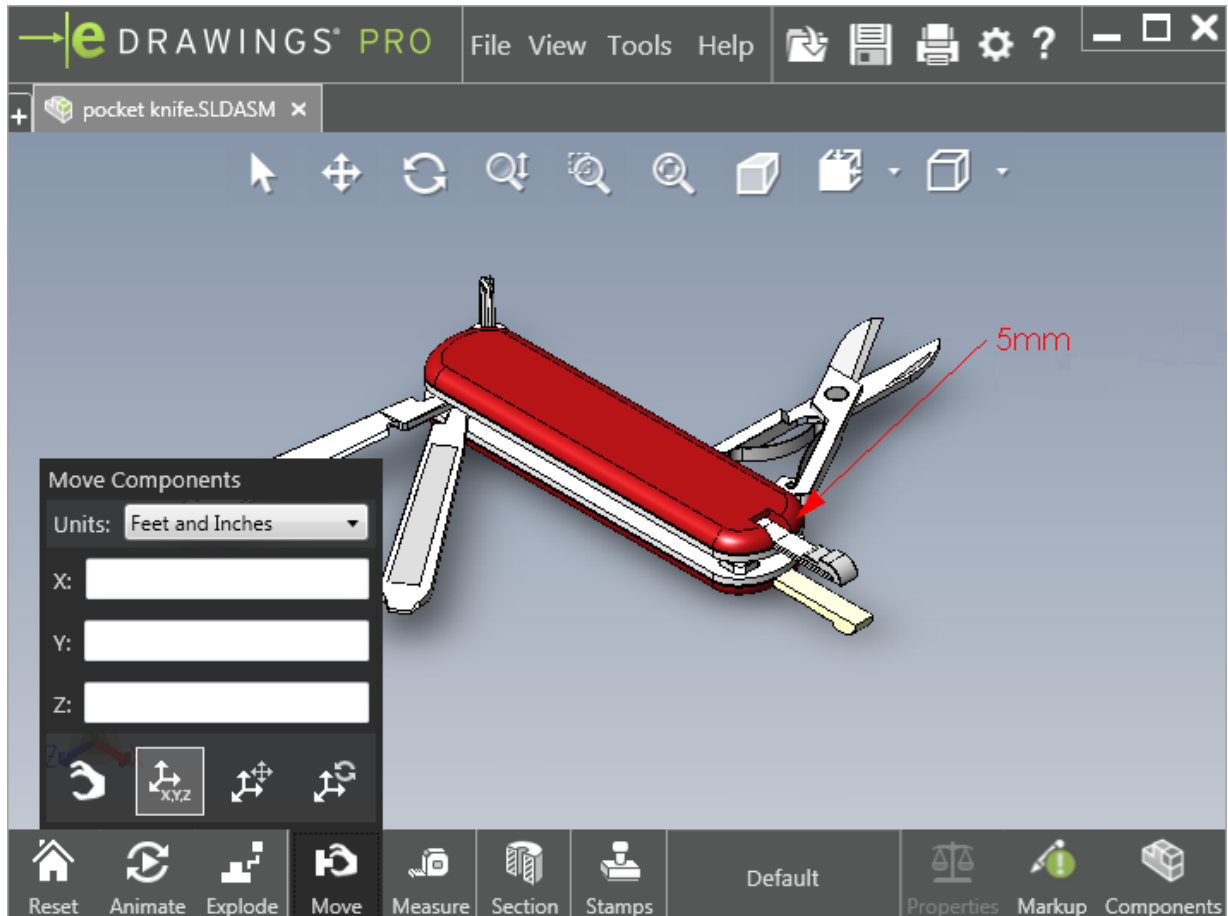

Removes the STEP file from the eDrawings document. When you close the eDrawings document, the software prompts you to save changes. If you do not save the changes, the STEP file remains attached to the eDrawings file.

User Interface Enhancements

User interface updates streamline your overall workflow.



Enhancement	Description
Quick access toolbar	Contains the Open, Save, Print, and Options tools. 
Units for Feet and Inches	Available when using the Move Component  tool.
Open + button next to tabs of other open documents	Lets you open a new document.

Enhancement	Description
Configuration names	Appear in the bottom of the window to indicate the active configuration. (SOLIDWORKS files only.)
Drawing sheet names	Appear in the bottom of the window to indicate the active sheet. (SOLIDWORKS files only.)
Markups	Graphical indicators notify you if the file contains a markup  and if a comment is associated to a markup  . 
Recent Documents	Higher up in the File menu for easier access.

Zooming In and Out

You can change the direction of the mouse wheel for zooming in and out.

To change the zoom direction of the mouse wheel:

1. Click **Options**  or **Tools > Options**.
2. In the dialog box, on the General tab, select **Reverse mouse wheel zoom direction**.
3. Click **OK**.

14

SOLIDWORKS Electrical

This chapter includes the following topics:

- **Connection Point Display**
- **Global Project Drawing Styles**
- **Global Wire Mark Display**
- **Multilevel Terminals**
- **Natural Sort Option for Marks**
- **Other Enhancements for SOLIDWORKS Electrical**
- **Project Level Attribute Styles**
- **SOLIDWORKS Electrical and SOLIDWORKS Routing Integration**
- **Symbol Editor**
- **Terminal Strips**
- **Unused Wires**
- **User Data for Manufacturer Parts**
- **Wire Numbering Group**

SOLIDWORKS Electrical is available as a separately purchased product.

Connection Point Display

You can display connection points when symbols are not connected.

On the Graphic tab, set **Display** to **When not connected**.

Global Project Drawing Styles

You can define global settings that apply to all schematic drawings of the project. The settings ensure that every document has the same characteristics without you performing manual updates, to achieve consistency.

The drawing settings are saved in a template file that manages different sets of drawing styles.

To set the drawing styles, on the Project tab, click **Project** > **Configurations** > **Drawing styles**.

Global Wire Mark Display

In the Wire style manager dialog box, you can globally change options for displaying wire labels, wire marks, equipotential marks, and equipotential labels for all wires.

Multilevel Terminals

You can independently mark each level of multilevel terminals and set specific rules for renumbering multilevel marks.

Level definition dialog box

You can set:

- | | |
|---|---|
| Use terminal and level mark (1.1, 1.2, 2.1, 2.2) | Applies the <code>terminalmark.levelmark</code> numbering format. |
| Use level marks (1, 2, 3, 4) | Applies a unique mark to each level of multilevel terminals. |

To access this dialog box, in the schematic, component tree, or Terminal strip manager, right-click and click **Terminals > Define levels**.

Renumber terminal strip terminals dialog box

You can set renumber order options to:

- **Vertical** or **Horizontal**
- **Bottom to Top** or **Top to Bottom**

To access this dialog box, in the Terminal strip manager, click **Advanced > Renumber**.

Component properties dialog box

On the Mark and data tab, after you set the levels, you can set individual component properties to use **Automatic**, **Manual**, or **Use level marks**.

To access this dialog box, in the schematic, right-click and click **Terminals > Component properties** or right-click the component tree and click **Select properties**.

Natural Sort Option for Marks

You can set the sort method of marks throughout the project by root and number sort or natural sort.

To set the natural sort for marks:

1. On the Project tab, click **Configurations > Project > Mark**.
2. Under **Sort by mark**, click one of the following for **Sort by mark mode**:
 - **Order by root and number, first automatic, manual after**

- **Order by tag alphabetically natural, mixing automatic and manual marks**

Other Enhancements for SOLIDWORKS Electrical

For additional information about these enhancements, see *SOLIDWORKS Electrical Help*.
SOLIDWORKS Electrical enhancements include:

Library	Added fields for prefabricated cable lengths and manufacturer part data file link.
Marks	<ul style="list-style-type: none"> • You can set the Manual mark mode as the default when using insert symbol. • You can edit the Automatic/Manual mark mode when you select multiple objects. • Renumber marks include harnesses.
Import/export	<ul style="list-style-type: none"> • In the file selector for outputs, you can filter on Opened drawings only to keep only the drawing opened by the current user. • Import DWG files can reconnect lines that are close to each other according to the offset distance you specify.
User interface	<ul style="list-style-type: none"> • In Cross reference settings, you can set whether to use the cross reference limit defined in the title block. • When you update or replace a title block in a drawing, the Display Task dialog box lets you apply the changed title block to only the selected drawing or to all project schematics in the project that use the same title block. • More formulas are available on the Font tab for cable core and cable text to customize text displayed on drawings for Origin-Destination and Function/Location Outline.
Open and archive	<ul style="list-style-type: none"> • The software retains the most recent file from each project. It reopens the last 2D or 3D file when you open a project. • In the archive environment, you can set an option to archive All projects.

Project Level Attribute Styles

You can define a common style for attributes that applies everywhere the attribute is used in the project. For example, you can use the same attributes format in a symbol or title block without performing manual updates.

In the Project configuration dialog box, on the Attribute tab, you can create custom attributes or use predefined attributes.

SOLIDWORKS Electrical and SOLIDWORKS Routing Integration

You can create C-points and define mate references for electrical components from the Routing Library Manager instead of the Electrical Component Wizard.

To access the Routing Library Manager from the SOLIDWORKS Electrical 3D tab, on the SOLIDWORKS Electrical 3D CommandManager, click **Electrical Component Wizard**.

SOLIDWORKS Electrical 3D enhancements in the Routing Component Wizard tab of the Routing Library Manager let you:

- Define C-points, mate references, and component alignment using the same options as in the Electrical Component Wizard.
- Set **Select Component Type** to **DIN Rail Component**.

Symbol Editor

Enhancements to the Symbol editor are available when you modify attributes and work with passive symbols.

When you modify attributes, you can use the:

- **Multiple attribute** and **Replace attribute** commands to quickly modify the index and language of one or more attributes when you edit a symbol or title block. These commands are available in **Edit Symbol** on the contextual menu.
- **Modify Revision Index** command when you edit a title block.

When you use passive symbols, the following options are unavailable in the Symbol properties dialog box:

- **Manufacturer part**
- **Characteristics**
- **Options**

Terminal Strips

Accessory components	You can add accessory components to terminal strips, including end brackets, end covers, and separators. These are represented in terminal strip drawings.
Component properties dialog box	You can add Manufacturer parts and circuits for terminal strips.
Reorder terminals dialog box	You can set the sort criteria using Destination cable mark or Origin cable mark .

Terminal strip drawings

You can set the **Distance between cables** in terminal strip drawings.

Unused Wires

You can use project configurations to number wires and equipotentials, cables, and components with unused wire marks.

In the Wire and component numbering dialog box, for **Assign unused mark**, select **Wires and equipotentials, Cables**, or **Components**. If you select any of these options, the software reuses unused numbers when numbering new wires, otherwise it uses the current highest mark +1.

User Data for Manufacturer Parts

If you do not use the ERP data connection, user data fields are available for manufacturer parts.

Wire Numbering Group

You can start the wire and equipotential numbering at each project location.

In the Numbering group dialog box, set **Start numbering at** to **Project, Book, File**, or **Location**.

15

SOLIDWORKS Flow Simulation

This chapter includes the following topics:

- **Color Bar**
- **Component Explorer**
- **Free Surface**
- **Full Template**
- **Noise Prediction**
- **Plot Callouts**
- **Sector Periodicity**

SOLIDWORKS Flow Simulation is available as a separately purchased product that can be used with SOLIDWORKS Standard, SOLIDWORKS Professional, and SOLIDWORKS Premium.

Color Bar

On the Color Bar, you can change the value axis to logarithmic and orient the palette bar horizontally or vertically.

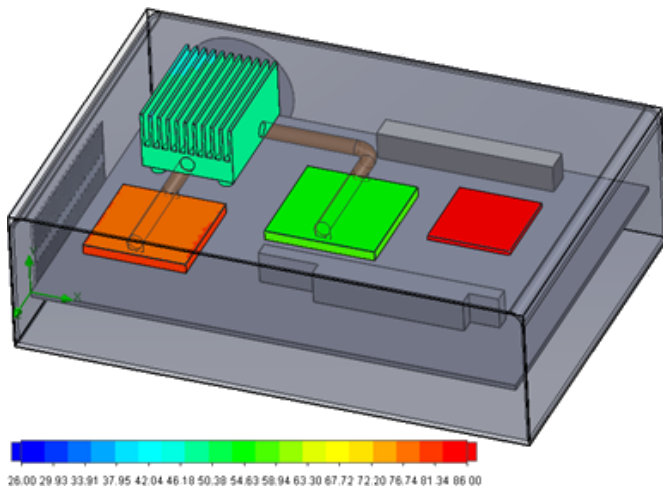

Component Explorer

In the Component Explorer, you can create and edit sources and materials from the table, and display total power.

Free Surface

Free surface lets you simulate flows with a freely moving interface between two immiscible fluids.

You can use the volume of fluid method (VOF) for tracking and locating the free surface (or fluid-fluid) interface.

The following pairs of fluids are available: gas-liquid and liquid-liquid. Any phase change transition, rotation, porous media, or fans are not allowed.

Full Template

You can save all project data to a template, such as boundary conditions, sources, and goals. This makes it easier to copy projects from model to model.

Noise Prediction

The Fast Fourier Transformation (FFT) algorithm converts a time signal to the complex frequency domain for transient analysis.

The FFT plot analyzes time-dependent pressure data using the FFT algorithm.

Plot Callouts

You can show the minimum and maximum values in callouts for cut and surface plots.

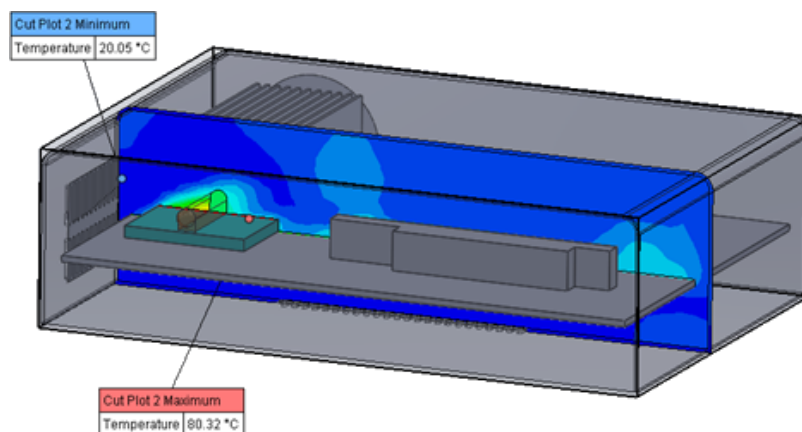

Sector Periodicity

You can simulate sector periodicity problems, including rotation and heat conduction in solids.

Phase transitions (including isothermal cavitation), high Mach number flows, and mixing plane rotation regions are not allowed. When performing the simulation, the rotation axis should be parallel to one of the global coordinate system axes.

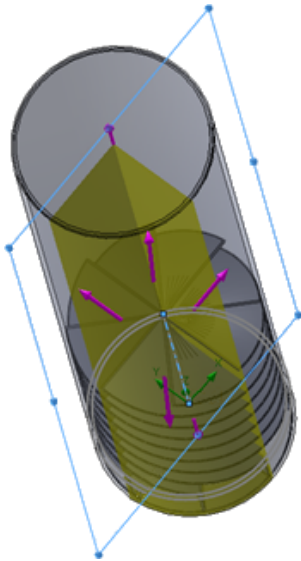

16

SOLIDWORKS 3D Interconnect

This chapter includes the following topics:

- **Additional File Formats Supported**
- **Additional Information Supported for Reading from Third-Party Native CAD Files**

Additional File Formats Supported

SOLIDWORKS 3D Interconnect now supports JT, STEP, IGES, and ACIS file formats.

JT Files

SOLIDWORKS 3D Interconnect supports JT files.

Version Supported: JT version 8.x, 9.x, and 10.x.

- 3D Interconnect reads parts containing JTBrep and XtBrep with visual properties.
- Assemblies with assembly structure of all four variations: Atomic, Monolithic, Shattered, and SameAs NX.

Limitations

SOLIDWORKS 3D Interconnect does not support:

- JT files with no Brep, or visualization data, or only with tessellation data.
- JT files that have desolated data
- Custom properties of JT files

STEP, IGES, and ACIS Files

SOLIDWORKS 3D Interconnect supports STEP, IGES, and ACIS file formats.

SOLIDWORKS 3D Interconnect can read **Reference Planes** and **User Defined Attributes** or **Custom Properties** from these neutral formats.

When you import custom properties from files, the translator reads user-defined attributes, if present, and writes them into SOLIDWORKS custom properties.

You can read STEP, IGES, and ACIS assembly files as a multibody files. From the System Options dialog box, you can choose to map and import the assembly structure as a part with multiple imported bodies or as a multibody part.

Additional Information Supported for Reading from Third-Party Native CAD Files ★

SOLIDWORKS 3D Interconnect reads the following additional information from third-party native CAD files:

- Assembly cut features
- Custom properties
- Material properties
- Unconsumed sketches and curves
- Reference axes from CATIA® V5 files only.

Assembly Cut Features

SOLIDWORKS 3D Interconnect can read assembly cut features from PTC® Creo and UG files.

You can optionally import the material properties, custom properties, and unconsumed sketches and curves from these files. To import these entities, in the System Options dialog box, click **Import** and select the required entity.

Custom Properties

SOLIDWORKS 3D Interconnect can read custom properties, metadata, or user-defined attributes from third-party native CAD files and map them to the custom properties of SOLIDWORKS.

SOLIDWORKS 3D Interconnect can read custom properties from these formats:

- ACIS
- Autodesk® Inventor
- CATIA® V5
- IGES
- PTC® Creo
- Solid Edge®
- STEP
- UG

The custom properties are locked when the third-party CAD file and the SOLIDWORKS file are linked. To overwrite these properties, you must break the link.

Material Properties

SOLIDWORKS 3D Interconnect can read the material properties from third-party native CAD files. SOLIDWORKS 3D Interconnect reads only the material name and density attributes.

Unconsumed Sketches and Curves

SOLIDWORKS 3D Interconnect can read unconsumed sketches or curve data from third-party native CAD files. Unconsumed sketches are sketches that are not consumed by any feature. These sketches read the curve data from third-party native CAD files and form single 2D or 3D sketches.

17

SOLIDWORKS Inspection

This chapter includes the following topics:

- **SOLIDWORKS Inspection Add-in**
- **SOLIDWORKS Inspection Standalone**

SOLIDWORKS Inspection is available as a separately purchased product that can be used with SOLIDWORKS Standard, SOLIDWORKS Professional, and SOLIDWORKS Premium or as a completely separate application (see *SOLIDWORKS Inspection Standalone*).

SOLIDWORKS Inspection Add-in

SOLIDWORKS Part and Assembly Support

You can create complete inspection reports using existing SOLIDWORKS part and assembly files (*.sldprt and *.sldasm).

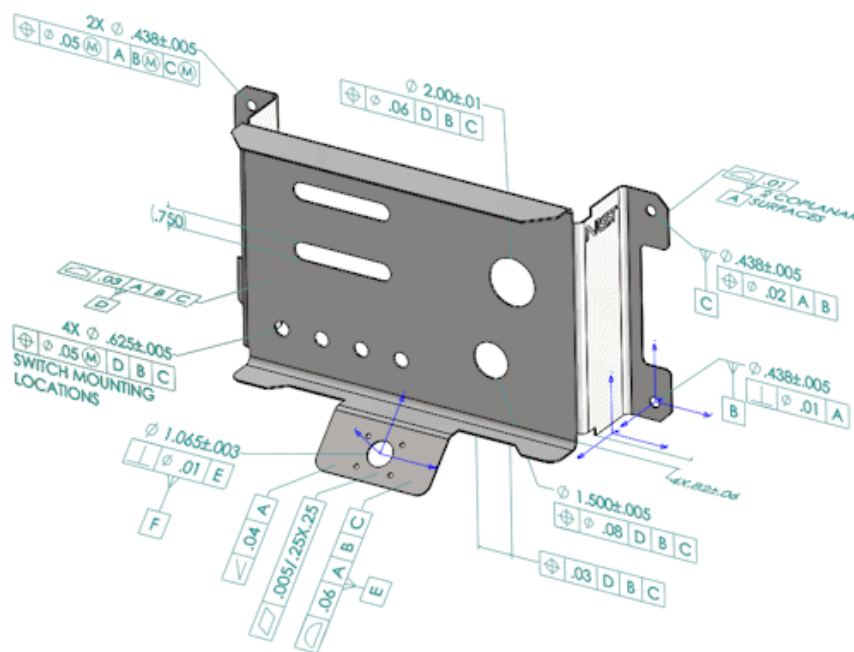

When you open a SOLIDWORKS part or assembly that contains 3D annotations or Product and Manufacturing Information (PMI), you can create a new inspection project and extract all the information for the inspection checklist.

To create an inspection report from a SOLIDWORKS part or assembly:

1. Click **New Inspection Project** (CommandManager).
2. Select project settings and extraction settings.

Use the check boxes to set up the project. For example, you can include or exclude **Dimensions, Notes, GD&Ts, and Hole Callouts**, SOLIDWORKS Inspection then adds the balloons to the PMI. Quality inspectors can then refer to the inspection spreadsheet and the 3D model to understand which characteristics to inspect.

You can use either **Automatic** or **Manual** extraction mode.

The Inspection characteristics are listed in the Characteristic Tree. You can modify the properties of a characteristic to include additional information such as Operation, Classification, and Method of Inspection. Additionally, you can reorder them.

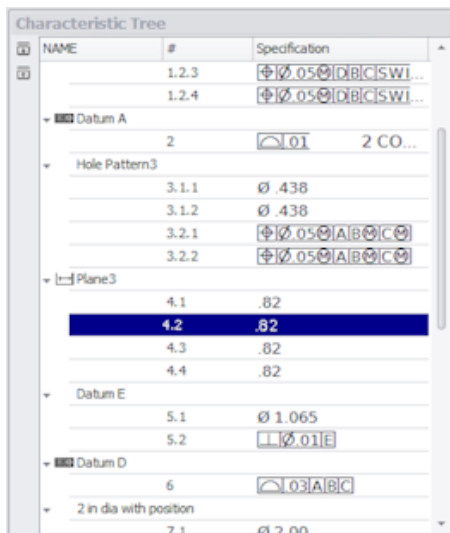

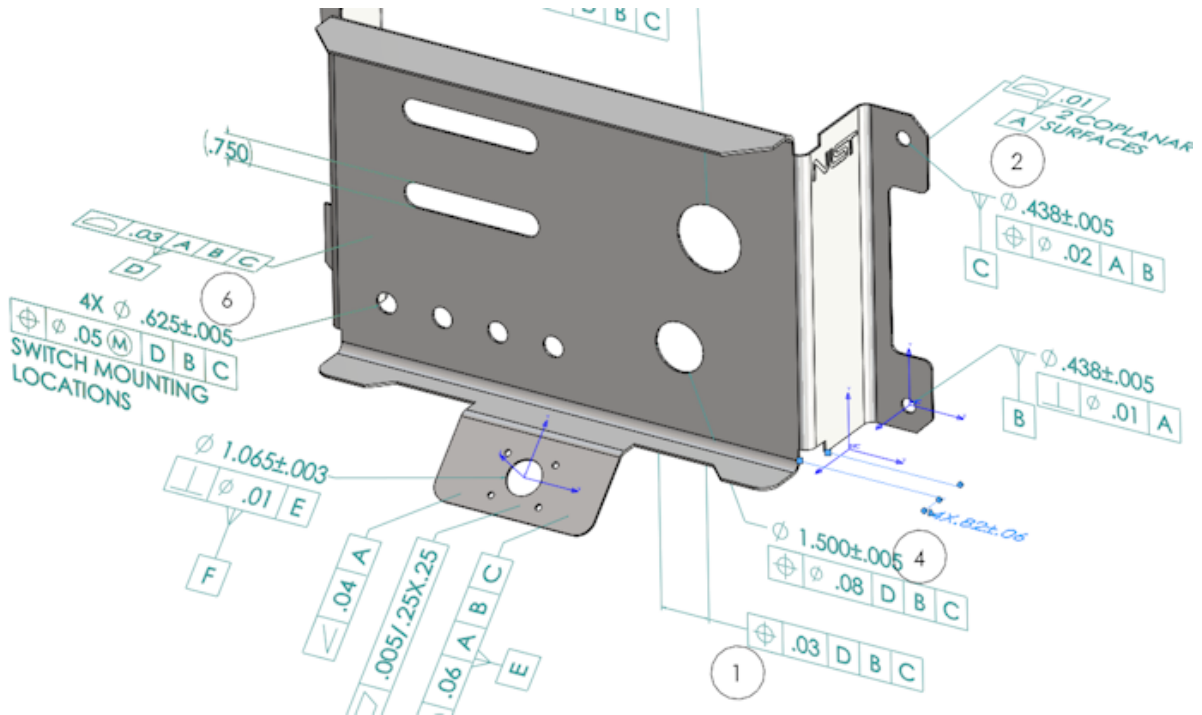

When the project is complete, you can generate:

- Microsoft® Excel report
- 2D PDF
- 3D PDF (if SOLIDWORKS MBD is available)
- eDrawings file

SOLIDWORKS Inspection Standalone

2D File Support

You can open and import 2D files from other CAD systems directly into an inspection project.

SOLIDWORKS Inspection 2018 supports these formats:

- AutoCAD® DWG files
- CATIA® V5 CATDrawing files

You can use the Smart Extract feature to extract one or more characteristics based on predefined settings.

After completing the inspection project, you can generate a Microsoft Excel file or a 2D PDF.

3D File Support

You can open and import 3D files from other CAD systems directly into an inspection project.

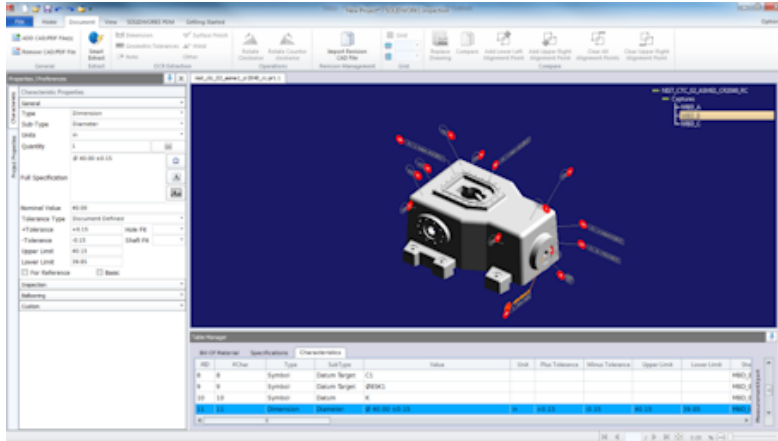

SOLIDWORKS Inspection 2018 supports these formats:

- 3D XML files
- PTC® and Creo Parametric files
- CATIA® V5 CATPart and CATProduct files

You can navigate between the different views of the 3D file using the navigation tree in the top right corner.

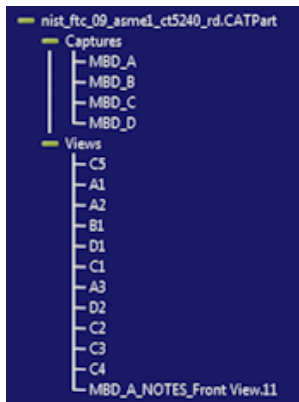

The characteristics are ballooned and added to the Bill of Characteristics.



After completing the inspection project, you can generate a Microsoft Excel file, a 2D PDF, or a 3D PDF.

Balloon Sequences

You can create balloon sequences in options and assign them to project characteristics.

You can do the following:

- To access balloon options, on the Home tab, click **Options** > **Project Options** > **Ballooning**.

- To add a balloon sequence, click .
- To remove a balloon sequence, click .
- Under **Balloon Sequence**, you can customize the **Sequence Name** and **Starting Value**.

Characteristics that you balloon are numbered based on the sequence selected in the CommandManager or in the characteristic window. When you select a sequence, all new characteristics start at the **Starting Value** and increment by 1. If a sequence already has characteristics, any new characteristic begins at the end of the list.

If you modify a sequence in the options, balloon numbers update accordingly.

Balloon sequencing, incrementing, and customizable numbering must be used independently of one another in a project.

CMM Data Management Import

There are new filters that help identify assigned and unassigned items.

Create and Place Sub-Balloons

When a characteristic refers to multiple instances of a feature, you can add multiple balloons to the drawing to identify each instance.

For example, this radius refers to two fillets:



To add multiple balloons:

1. In the Table Manager:
 - a) Create a line for each instance.
 - b) Right-click an instance and click **Create and Place Sub balloons**.
2. Click anywhere in the document to place additional balloons.

In this example, you add balloon **2.2**. Balloon **2** automatically changes to **2.1**.

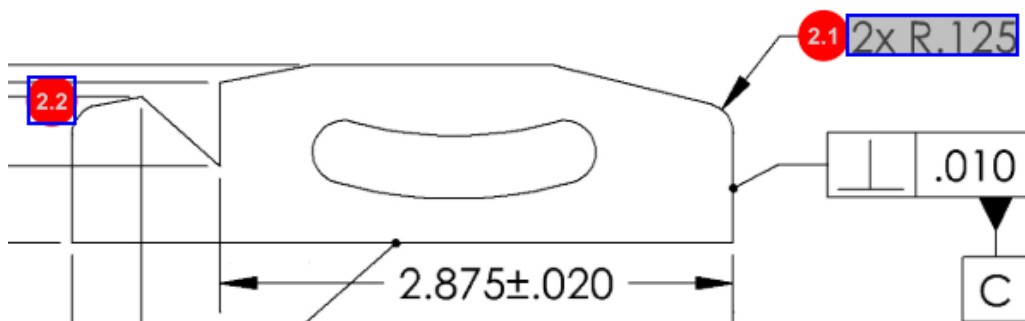

Customizable Balloon Numbering

You can renumber characteristics in the **Bill of Characteristics** and include gaps.

To renumber characteristics, on the Characteristics tab, double-click the Characteristics Number field (**#Char**) and type the new number. All subsequent characteristics are renumbered accordingly.

Table Manager

Bill Of Material Specifications Characteristics

#ID	#Char	Type	SubType	Value	Unit	Plus Tolerance	Minus Tolera
1	1	Note	Note	BREAK ALL SHARP CORNERS TO .05 INCHES.			
2	2	Note	Note	INTERPRET PER ASME Y14.5-2003			
3	3	Note	Note	HEAT TREAT PER GWS 1-08.			
4	4	Dimension	Linear Dimen...	88.9	in	+0.05	-0.10
5	5	Dimension	Linear Dimen...	6.4 / 6.3	in		
6	6	Dimension	Linear Dimen...	69.85	in	+0.5	-0.5
7	7	Dimension	Linear Dimen...	25.4	in	+0.5	-0.5
8	8	Dimension	Linear Dimen...	15.88	in	+0.5	-0.5
9	9	Dimension	Linear Dimen...	7.47	in	+0.5	-0.5

Table Manager

Bill Of Material Specifications Characteristics

#ID	#Char	Type	SubType	Value	Unit	Plus Tolerance	Minus Tolera
25	25	Note	Note	BREAK ALL SHARP CORNERS TO .05 INCHES.			
26	26	Note	Note	INTERPRET PER ASME Y14.5-2003			
27	27	Note	Note	HEAT TREAT PER GWS 1-08.			
28	28	Dimension	Linear Dimen...	88.9	in	+0.05	-0.10
29	29	Dimension	Linear Dimen...	6.4 / 6.3	in		
30	30	Dimension	Linear Dimen...	69.85	in	+0.5	-0.5
31	31	Dimension	Linear Dimen...	25.4	in	+0.5	-0.5
32	32	Dimension	Linear Dimen...	15.88	in	+0.5	-0.5
33	33	Dimension	Linear Dimen...	7.47	in	+0.5	-0.5



Balloon sequencing, incrementing, and customizable numbering must be used independently of one another in a project.

Customizable Tolerance Type

You can customize default tolerances if an explicit tolerance is not specified in the 2D or 3D file for one or multiple characteristics.

In addition to the **Linear** and **Angular** default tolerances, you can add new tolerances.

You can do the following:

- To access the tolerance options, on the Home tab, click **Options > Project Options > General**.
- To add a new tolerance, under **Default Tolerances**, click **+** at the top of the table.
- To rename a tab, double-click it and type the new name.
- Use  and  to add and remove lines in the tolerance table.
- You can select tolerance values **By Precision** or **By Range**.

After completing the tolerance table, you can select it in the characteristic window.

Explode Note

If a drawing note contains multiple characteristics to inspect, you can explode the note into multiple instances.

To explode a note:

1. In the Table Manager, right-click the note and select **Explode Note**.
2. Select each characteristic and create a new instance or use **Auto-Explode**.

You can also add, remove, copy, and combine rows.

Export to CAMS XML and Verisurf

You can export your inspection projects to CAMS XML and Verisurf.

Export to QualityXpert Improvements

In QualityXpert, you can use a mobile device to publish your inspection plans to the web for inspection on the shop floor.

ExtractionXpert

The ExtractionXpert™ tool improves Optical Character Recognition (OCR) readings.

ExtractionXpert automatically tries different OCR settings such as **Sharpen**, **Dilate**, and **Edge Enhancement**. The tool uses more than 200 combinations to recommend the best settings based on the entered values.

ExtractionXpert accounts for scaling, so you no longer need to manually rescale .pdf and .tiff drawings. Therefore, in **Options > Project Options**, the Drawings tab has been eliminated.

Full Specification

When extracting characteristics from a 2D or 3D file, the full specification is calculated in the characteristic window. Some companies require their users to have the full specification (for example, tolerances, degree, diameter symbols) displayed in the inspection report.

Ignore Basic Dimensions

You can ignore basic dimensions from measurements input so they are not flagged.

Improved Optical Character Recognition

An enhanced Optical Character Recognition (OCR) engine improves the recognition of documents and fonts, and requires less user input.

Improved User Interface

The user interface is improved for added clarity.

- Menus, dialogs, and buttons are updated to be more consistent.
- Options and settings are reorganized.
- In the Bill of Characteristics, the status for items such as Key and Basic characteristics is now shown as **True** or **False** instead of a check mark.

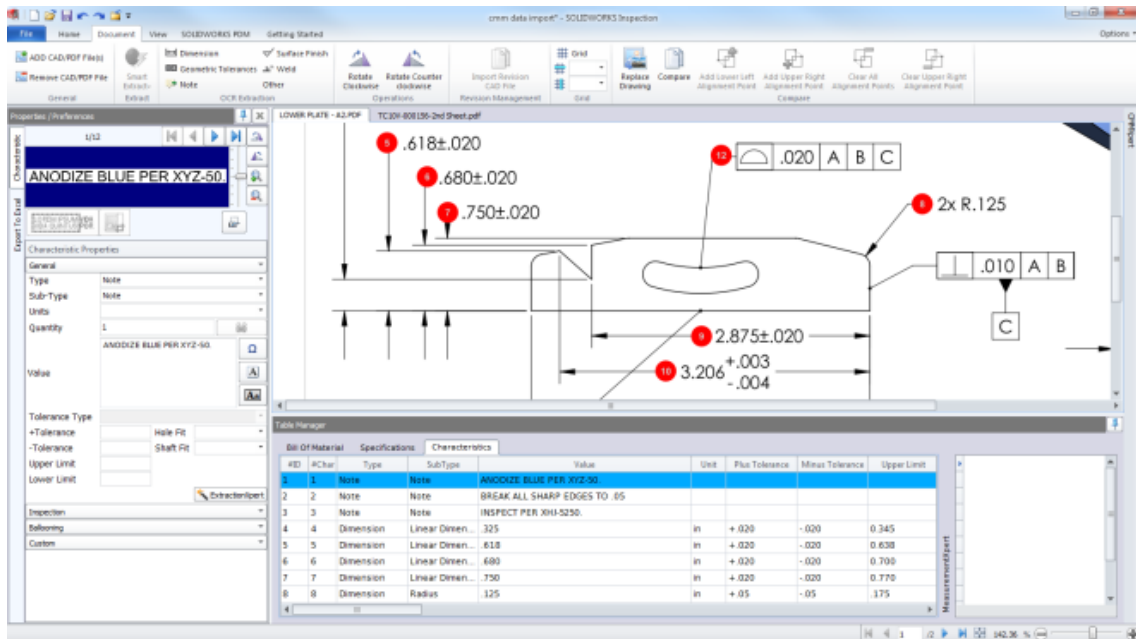

Merge Characteristics

You can merge multiple characteristics into one.

For example, this hole dimension is listed as three separate characteristics. You want it to be listed as a single characteristic.



To merge characteristics:

1. In the Table Manager, select the characteristics to merge.
2. Right-click and select **Merge Characteristics**.

The characteristics are combined into one.

Net-Inspect Options

Net-Inspect is a web-based quality management system used by many large companies to manage their inspection processes both internally and with suppliers worldwide.

To set Net-Inspect options, click **Home > Options > Net-Inspect Options**.

Predefining Balloon Appearances

In **Project Options**, under **Ballooning**, you can use the Characteristic Identification feature to predefine unique balloon appearances for special characteristics for easy identification when performing an inspection.

The Characteristic Identification feature can be applied to Key Characteristics. Therefore, the Key Characteristics options **Identified** and **Placement** have been eliminated.

	Classification	Prefix	Suffix	Balloon shape	Fill color	Border color	Font color	Font Size	Fit	Identification Criteria
1	Critical	*		Triangle	Yellow	Black	Black	12	2	
2	Major		K	VDA Balloon	Red	Red	Black	12	3	

Publish Reports with Document Snapshots

You can include captures, views, and drawing sheets in Microsoft Excel inspection reports.

You can select views and sheets to include in published reports. Also, you can manually create and include snapshots. You can reorder the snapshots before exporting to Microsoft Excel.

	Publish	Name/Sheet #	Type	File Name
	<input type="checkbox"/>			
	<input type="checkbox"/>			
	<input type="checkbox"/>			
	<input type="checkbox"/>			
	<input type="checkbox"/>			
	<input type="checkbox"/>			
	<input type="checkbox"/>			
	<input type="checkbox"/>			
	<input type="checkbox"/>			
	<input type="checkbox"/>			
	<input type="checkbox"/>			

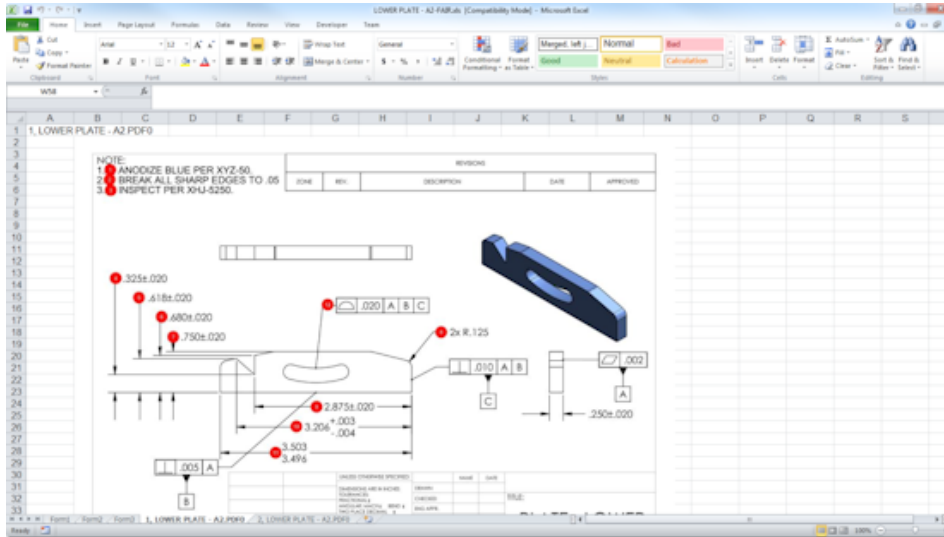

Revision Management

You can use the Revision Management tool to analyze changes between two CAD files and view a summary of all added, removed, or modified annotations.

SOLIDWORKS Inspection can automatically process all of the changes between revisions or highlight changed items in the project, allowing you to review each item individually.

The manual revision mode provides a summary of the changes as well as instruction to make the changes. The automatic mode displays a summary with options and user preferences for automatic processing.

Sampling

Acceptance Quality Limit (AQL) is a method of sampling that is used by many companies as the standard tool for choosing sample size for product inspection. You can define sampling and AQL in the SOLIDWORKS Inspection Standalone application for an entire project or for each individual characteristic.

Smart Extract

The Smart Extract tool lets you extract multiple characteristics when the PDF document contains a searchable text layer that supports Smart Extract.

Smart Extract supports PDFs created from the following applications:

- CATIA V5
- Solid Edge

To extract characteristics, click **Smart Extract** (CommandManager) or right-click and click **Smart Extract**. You can extract a single characteristic or multiple characteristics.

#ID	#Char	Type	SubType	Value
1	1	Geometric Tol...	Position	Ø7.14 THRU Ø12.0598 @ ABC

This is useful for extracting GD&T without manually recognizing each element.

Using predefined settings, you can extract multiple characteristics at once. The quality of the extraction depends on the software that was used to create the 2D drawing.

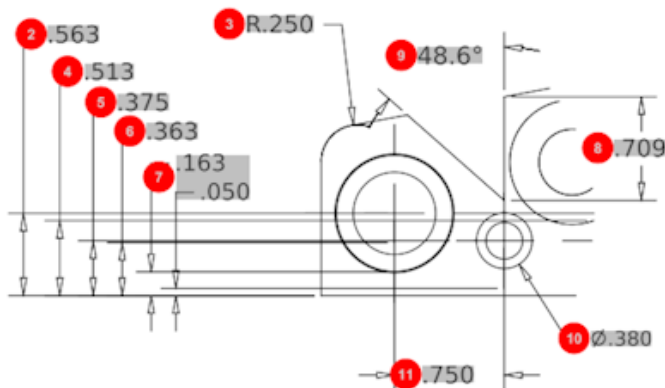
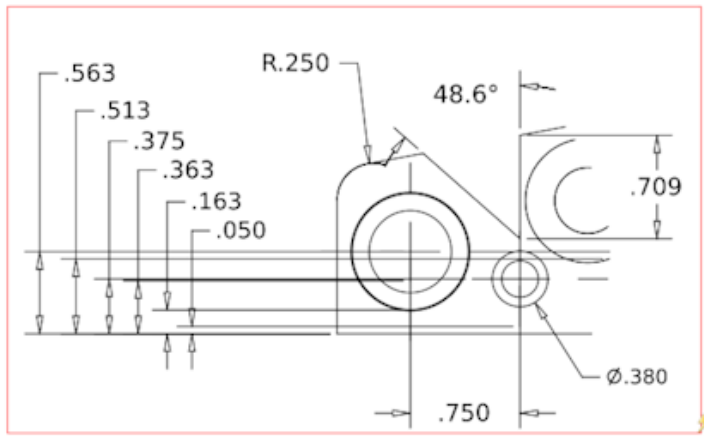

#ID	#Char	Type	SubType	Value	Unit	Plus Tolerance	Minus Tolerance
1	1	Geometric To...	Cylindricity	<u>.025</u>	in		
2	2	Dimension	Linear Dimen...	.563	in	+ .005	- .005
3	3	Dimension	Radius	R.250	in	+ .005	- .005
4	4	Dimension	Linear Dimen...	.513	in	+ .005	- .005
5	5	Dimension	Linear Dimen...	.375	in	+ .005	- .005
6	6	Dimension	Linear Dimen...	.363	in	+ .005	- .005
7	7	Dimension	Linear Dimen...	.163 / .050	in		
8	8	Dimension	Linear Dimen...	.709	in	+ .005	- .005
9	9	Dimension	Angle Dimen...	48.6°	deg	+1°	-1°
10	10	Dimension	Diameter	Ø.380	in	+ .005	- .005

Undo and Redo

Undo and Redo are available to cancel or redo the last action.

18

SOLIDWORKS MBD

This chapter includes the following topics:

- **3D PDF Templates**
- **3D PMI Compare Versions**
- **3D Views Slideshow**
- **Bill of Materials**
- **Configuration-specific Properties in 3D PDF**
- **Import PMI**
- **Insert a Note in a 3D PDF Field**
- **MBD Templates**

SOLIDWORKS MBD is available as a separately purchased product that you can use with SOLIDWORKS Standard, SOLIDWORKS Professional, and SOLIDWORKS Premium.

3D PDF Templates

New 3D PDF templates are available for parts and assemblies.

In addition, there are custom versions that you can use as a basis for your specific needs.

To access the 3D PDF templates:

1. Click **3D PDF Template Editor**  (SOLIDWORKS MBD toolbar).
2. Click **Open** .

SOLIDWORKS
CAD 3D DESIGN

Part Number: Custom property Placeholder
Comments: PDF Area Placeholder.

Date: Custom property Placeholder
Revision: Custom property Placeholder
Designed By: Custom property Placeholder
Material: Custom property Placeholder
Weight: Custom property Placeholder

APPROVALS		
TITLE	NAME	DATE
DRAWN	Custom property Placeholder	Custom property Placeholder
CHECKED	Custom property Placeholder	Custom property Placeholder
APPROVED	Custom property Placeholder	Custom property Placeholder

GENERAL NOTES
UNLESS OTHERWISE SPECIFIED:
DIMENSIONS ARE IN MILLIMETERS
MODEL IS REQUIRED TO COMPLETE PRODUCT DEFINITION
FOR ALL NON-DIMENSIONED FEATURES IN THIS DOCUMENT
ALL DIMENSIONS OBTAINED FROM THE MODEL ARE BASIC
UNLESS OTHERWISE SPECIFIED
THE GENERAL TOLERANCE FOR ALL UNTOLERANCED SURFACES = 0.2MM
INTERPRET DRAWING IN ACCORDANCE WITH ASME Y14.5-2005, AND ASME Y14.100-2013

PRIMARY VIEWPORT

File name: Custom property Placeholder Sheet: 1 Of 2

Multipage Part (a4 landscape)

SOLIDWORKS
CAD 3D DESIGN

Part Number: Custom property Placeholder
Comments: PDF Area Placeholder.

Date: Custom property Placeholder
Revision: Custom property Placeholder
Designed By: Custom property Placeholder
Material: Custom property Placeholder
Weight: Custom property Placeholder

APPROVALS		
TITLE	NAME	DATE
DRAWN	Custom property Placeholder	Custom property Placeholder
CHECKED	Custom property Placeholder	Custom property Placeholder
APPROVED	Custom property Placeholder	Custom property Placeholder

GENERAL NOTES
UNLESS OTHERWISE SPECIFIED:
DIMENSIONS ARE IN MILLIMETERS
MODEL IS REQUIRED TO COMPLETE PRODUCT DEFINITION
FOR ALL NON-DIMENSIONED FEATURES IN THIS DOCUMENT
ALL DIMENSIONS OBTAINED FROM THE MODEL ARE BASIC
UNLESS OTHERWISE SPECIFIED
THE GENERAL TOLERANCE FOR ALL UNTOLERANCED SURFACES = 0.2MM
INTERPRET DRAWING IN ACCORDANCE WITH ASME Y14.5-2005, AND ASME Y14.100-2013

PRIMARY VIEWPORT

File name: Custom property Placeholder Sheet: 1 Of 2

Multipage Part Custom (a4 landscape)

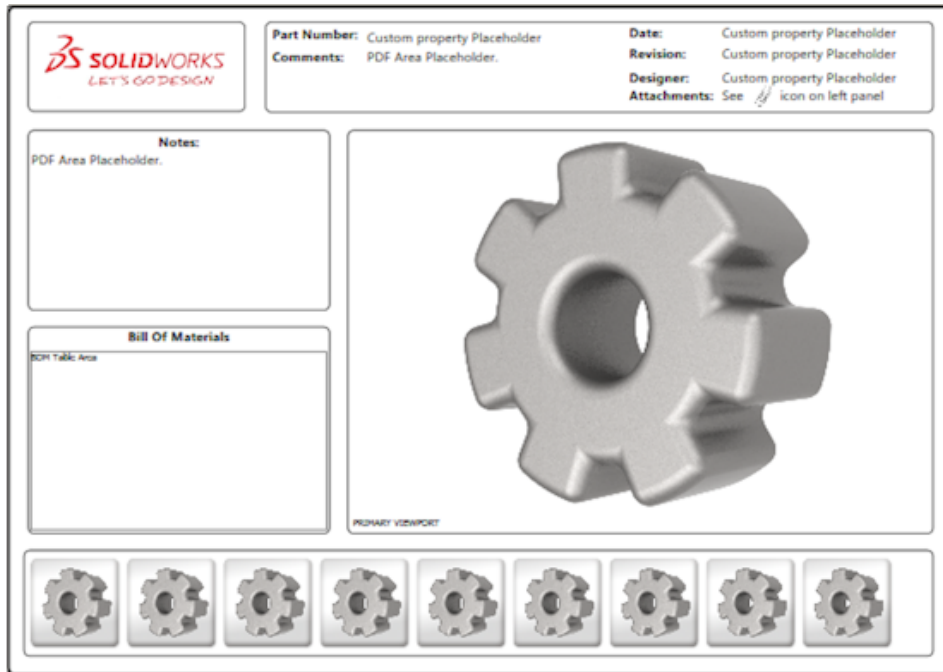

Multipage Assembly (a4 landscape)

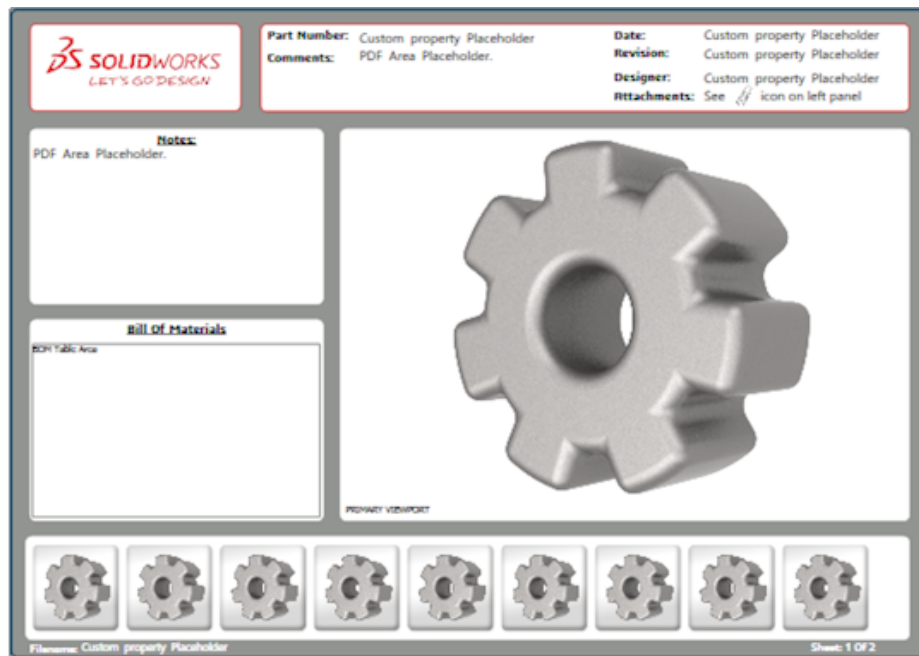

Multipage Assembly Custom (a4 landscape)

3D PMI Compare Versions

Using the 3D PMI Compare tool, you can compare PDM revisions of the same document.

To compare PDM revisions of the same document:

1. Click **Tools > Compare > 3D PMI**.
2. In the Task Pane, select the **Reference document**.
3. Select **Within SOLIDWORKS PDM**.
4. Under **Within SOLIDWORKS PDM**, select the PDM revisions in **Version 1** and **Version 2**.
5. Click **Run Comparison**.

3D Views Slideshow

You can watch 3D Views as a slideshow from the 3D PDF.

In a 3D PDF, click **Play** ► in the preview pane to automatically sequence through the model views. To stop or pause the presentation, click **Pause** ||.

Bill of Materials

When you publish a model containing a bill of materials to 3D PDF, you can determine which columns to include.

To specify the columns in a bill of materials:

1. In a model that contains a BOM, in the Publish to 3D PDF PropertyManager, click .
2. Under **Output BOM Table**, in **Column List**, select the columns to include.
3. To specify the number of columns to display in the 3D PDF, under **Columns in grid**, select the number of columns.

For example, if you select **2** for **Columns in grid** and you select more than two in **Column List**, the 3D PDF displays the values of 2 columns in the BOM. When you select a BOM row, the remaining column values appear in the BOM.



4. To display all of the BOM columns in the 3D PDF, select **Show all columns in PDF**.
5. Set other options.
6. Click .

Configuration-specific Properties in 3D PDF

You can insert configuration-specific properties in text fields and tables when you publish a model to 3D PDF. For notes, there is a 3D PDF Template Editor option that assigns the property as configuration-specific.

Inserting Configuration-specific Properties in a Text Field

To insert configuration-specific properties in a text field:

1. In the SOLIDWORKS 3D PDF Template Editor, click **Text** .
2. Click to place the text block on the page.
3. In the PropertyManager, click **Custom Property Field** .
4. Under **Custom Property Field**, select **Configuration Specific**.
5. Set the options.
6. Click .

Inserting Configuration-specific Properties in a Table

To insert configuration-specific properties in a table:

1. In the SOLIDWORKS 3D PDF Template Editor, click **Generic Table** .
2. In the Open dialog box, select a table and click **Open**.
3. Optionally, drag and resize the placeholder on the template.
4. Click outside of the table to release it.

Import PMI

You can import PMI (Product Manufacturing Information) with NX, Creo, and STEP AP242 formats as semantic graphical annotations.

You can assign color to graphical annotations. Click **Tools > Options > System Options > Colors**. Under **Color scheme settings**, select **Graphical Annotations**.

Insert a Note in a 3D PDF Field

You can select and insert notes, such as a GTOL, from a part or assembly into their own fields in a published 3D PDF.

To insert a note in a 3D PDF field:

1. In the 3D PDF Editor, click **Imported Notes** .
2. Click to place the **Imported Note Placeholder** on the template page.
3. Set the properties.

4. Click .
5. Save the template.

MBD Templates

MBD templates for parts and assemblies are included with all versions of SOLIDWORKS 2018 where the text sizes scale properly to the component and assembly sizes.

The new MBD templates have predefined settings based on your model size. When you use these templates, you will automatically get the proper scaling for your model and text. For example, select **Part 0001 mm to 0010 mm** if the model you are designing will be in the range of one to ten mm. This template is designed for this part size, which helps simplify your work.

The new templates are installed with your SOLIDWORKS installation.

To use a template:

1. Click **File** > **New**.
2. In the New SOLIDWORKS Document dialog box, click the **MBD** tab.
3. Select a template.
4. Click **OK**.

19

Model Display

This chapter includes the following topics:

- **Offloaded Rendering**

Offloaded Rendering

Offloaded rendering lets you send a rendering to another machine that uses the PhotoView 360 Net Render Client. Offloaded rendering frees up your computer while the rendering is calculated on another machine.

When you use offloaded rendering, two machines are required:



- | | |
|--------------------|---|
| Coordinator | The machine running the SOLIDWORKS software and PhotoView 360. The coordinator must have a license of SOLIDWORKS Professional or higher and an active subscription service license. |
| Client | The machine running the PhotoView 360 Net Render Client. The client does not need a SOLIDWORKS license. |

There are two types of offloaded rendering:

- | | |
|--------------------------------------|---|
| Single offloaded rendering | Sends a single static image to render on the client. |
| Scheduled offloaded rendering | Sends a single static image to the SOLIDWORKS Task Scheduler to start the task at a later time. |

Using Single Offloaded Rendering

To use single offloaded rendering:

1. Click **Options**  (Render Tools toolbar) or **PhotoView 360 > Options**.
2. In the PropertyManager:
 - a) Select **Network Rendering** and **Offload Rendering**.
 - b) Click .

When you render the model, it renders on the client that uses the PhotoView 360 Net Render Client. If the client is busy or unavailable, you are asked if you want to render on the coordinator or cancel the rendering. On the coordinator machine, you have full access to the SOLIDWORKS software while the offloaded rendering takes place.

Using Scheduled Offloaded Rendering

Use scheduled offloaded rendering to start the task in the SOLIDWORKS Task Scheduler at a later time, such as after business hours.

To use scheduled offloaded rendering:

1. Click **Schedule Render**  (Render Tools toolbar) or **PhotoView 360 > Schedule Render**.
2. In the dialog box:
 - a) Select **Start Offloaded Rendering Now**.
Start Offloaded Rendering Now is not available if the SOLIDWORKS Task Scheduler is performing tasks, a rendering is already scheduled, or if a rendering is currently taking place.
 - b) If there is already a task scheduled in the SOLIDWORKS Task Scheduler, select **Start after Previous Task** to put the task into the queue.
 - c) Click **Finish**.

SOLIDWORKS Task Scheduler schedules the rendering. If the client is busy or unavailable when the render task is scheduled to start, the coordinator machine performs the render.

20

Parts and Features

This chapter includes the following topics:

- **Advanced Hole**
- **Block Editing of Linked Custom Properties in Derived Parts**
- **Cosmetic Threads Improvements**
- **Creating a Bounding Box**
- **Defeature Tool Improvements**
- **Extracting Geometry from a Corrupted Solid Body**
- **Feature Freeze Bar Works with All Folders**
- **Hole Wizard Options to Match Size or Preserve Settings**
- **Mesh BREP Bodies**
- **More Control Over Custom Properties**

Advanced Hole

Customizing Advanced Hole Callouts

You can customize hole callouts for advanced holes, which is useful for manufacturing processes.

The manufacturing processes for holes do not always match the order shown in the advanced hole flyout. You can customize hole callouts that match the order and variables needed for manufacturing, then use the callouts in manufacturing drawings.

For example, the advanced hole flyout might show this order:

- (1) Nearside Counterbore
- (2) Straight
- (3) Straight Threaded

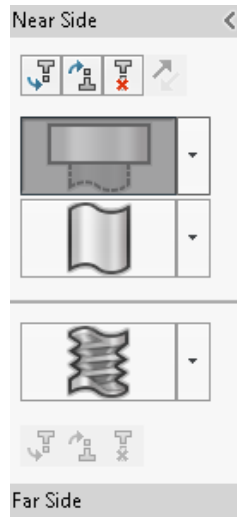

However, this is the order in which manufacturing creates the holes:

- (3) Straight Threaded
- (2) Straight
- (1) Nearside Counterbore

To customize advanced hole callouts:

1. In the Advanced Hole PropertyManager, under **Hole Callout**, click **Customize callout**.
2. To reorder the callouts, select the **Callout String** and click **Move Up** and **Move Down**.

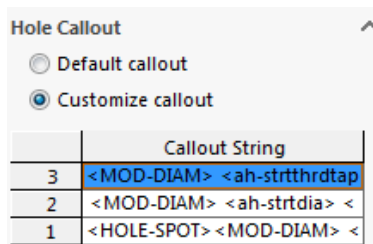

3. To customize a callout string, double-click it in the **Callout String** list and select variables. You can also select **Callout Variables** to display a list of all variables. Modified strings are marked with an asterisk in the list.
4. To restore the default settings for individual **Callout String** items, right-click a string and click **Restore Default String**.
5. To remove all customizations, under **Hole Callout**, click **Default callout**.

Default callout removes all customizations you made to all hole callouts in the PropertyManager.

Defining Hole Elements with Baseline Dimensions

You can use baseline dimensions to define advanced holes.

When you select this option in the Advanced Hole PropertyManager, the SOLIDWORKS software measures near and far side elements from the same initial baseline dimension. This option also sets the end condition automatically to **Offset from Surface** for each element in the hole stack.

The same hole stack can chain elements, defined with baseline dimensions, with other neighboring hole elements.

Other changes related to using baseline dimensions include:

- For a counterbore, countersink, or taper threaded element, you can select **Use standard depth** to ensure that the depth of the element is the same depth defined in the Hole Wizard data table.
- For a straight threaded element, you can select a formula from a drop-down list to calculate its depth.

To access this option, click **Insert > Features > Advanced Hole**. In the Advanced Hole PropertyManager, under **Near And Far Side Faces**, select a face and click **Use baseline dimensions**.

Block Editing of Linked Custom Properties in Derived Parts

On the **Custom Properties** tab in the **Task Pane**, you cannot edit or delete file properties and cut list properties which are linked to parent parts. These options will appear unavailable (grayed out).

Cosmetic Threads Improvements

When you mirror a feature, the geometry for cosmetic threads generates more reliably.

There are also improvements related to patterns, the hole wizard, and line representation for depth.

Creating a Bounding Box

With the **Bounding Box** tool in **Reference Geometry**, you can create a box that completely encloses a model within a minimum volume. You can create a bounding box for a multibody, single body, or sheet metal part.

In the Bounding Box PropertyManager, you can orient a bounding box by selecting a planar face of the part or a reference plane. When the part updates, the bounding box automatically resizes.



You can include hidden bodies and surfaces in the bounding box. You can also hide, show, suppress, and unsuppress a bounding box from a shortcut menu.

Four bounding box properties are available in the **Configuration Specific** tab of the Summary Information dialog box. The dimensions in these properties can help you determine the space required to ship and package product. You can reference these properties in BOMs and other tables.

Calculating a bounding box for a part with many faces can be time consuming. If a part has many faces, you should create the bounding box after you finish modeling the part.

Previously, you could only create a bounding box for a cut list item in weldments.



To create a bounding box and view its properties:

1. In a part document, click **Bounding Box**  (Reference Geometry toolbar) or **Insert > Reference Geometry > Bounding Box**.
2. In the Bounding Box PropertyManager, leave **Best Fit** selected and click .

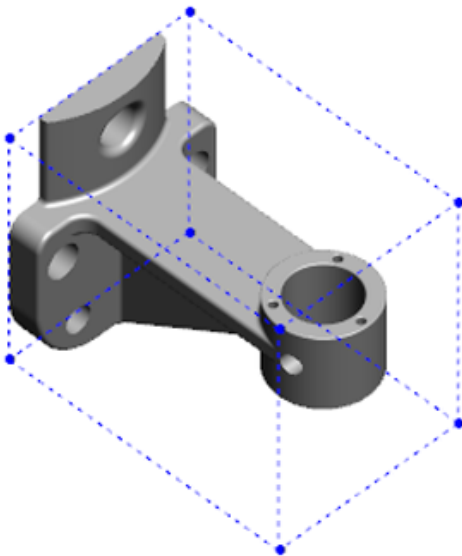
The software automatically calculates the bounding box for the part as shown. In the FeatureManager design tree, **Bounding Box** is added after **Origin**.



The bounding box calculated by the SOLIDWORKS software might not have the minimum volume for some bodies and parts. You should use past experience and experimental data to review the suggested bounding box, and modify it if necessary.

3. To view bounding box properties, click **File > Properties > Configuration Specific** tab.
Values for thickness, width, length, and volume of the bounding box are listed.
4. If you hide a body in the part, the bounding box automatically updates and only encloses the visible bodies in the model.
5. To edit the bounding box, in the FeatureManager design tree, right-click **Bounding Box**, and click **Edit Feature** . Then in the PropertyManager, click **Include hidden bodies** and click .

Defeature Tool Improvements

The **Defeature** tool is more reliable in displaying features that have been selected to keep, and in selecting and keeping holes, especially in spherical bodies.

When you save the results from the **Defeature** tool and select the option to save the model as a separate file, the file is saved as `Document Name_Defeature.sldprt`.

In a part or assembly, click **Defeature**  (Tools toolbar) or click **Tools > Defeature**.

Extracting Geometry from a Corrupted Solid Body



When the SOLIDWORKS software attempts to repair a corrupt file and cannot resolve the problem, the software prompts you with an option to extract geometry if the body data of the file is still intact.

If you accept this option, the software imports the geometry from the corrupted file into a new file. You can use the geometry and add features to create a new model. However, the new file will not have the feature history associated with the imported geometry.

Feature Freeze Bar Works with All Folders

The Feature Freeze bar freezes all features above the bar in the FeatureManager design tree even when the features in a folder were not created in chronological order.

Previously, the freeze bar could not freeze features in a folder if it contained sketches or features that had been created later than entities below the freeze bar. For example, suppose your part document contains Sketch1 and Sketch2, and you create Boss-Extrude1 feature from Sketch2 and Boss-Extrude2 feature from Sketch1. Then you add Boss-Extrude1 feature into Folder1. If you moved the freeze bar below Folder1, the software would not let you position it there, because Folder1 contains Sketch2, which is listed before Sketch1, in the design tree.

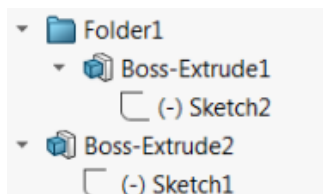

Now when you drag the freeze bar to Folder1, the software prompts you with a warning and temporarily unabsorbs Sketch1, so that it can freeze Folder1, Boss-Extrude1, and Sketch2. This behavior is consistent with how the rollback bar works with absorbed features.

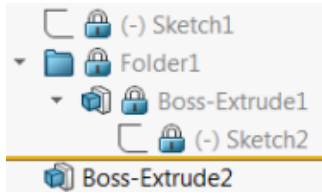

Another enhancement is that the **Feature** command displays when you right-click any feature in the FeatureManager design tree. It displays after the **Delete** command in the shortcut menu.

Hole Wizard Options to Match Size or Preserve Settings

The sizing matching functionality for Hole Wizard, Hole Series, and Advanced Hole has improved to match hole sizes when changing from one hole type to another.

In **Tools > Options > Hole Wizard/Toolbox**, you can choose between two options for size matching:

- **Preserve settings for each Hole Wizard hole type** uses legacy behavior to save settings for each hole type. For example, if the size setting for tapped holes is M6, that setting is not affected by the size settings of other hole types. This behavior was used by SOLIDWORKS version 2015 and earlier releases.
- **Transfer settings when changing Hole Wizard Hole type** attempts to match the size settings of the last hole type used and the size settings available for the new hole type. Matching is done based on string comparison. This behavior is set by default for all new and upgrade installations to preserve the existing SOLIDWORKS version 2017 behavior.
 - Example 1: If you create a counterbore hole and set the size at M6, and then create a countersink hole, the M6 setting carries over to the new hole type.
 - Example 2: If you create a counterbore hole and set the size at M6, and then change it to a tapped hole, the M6 setting carries over to the new hole type setting it to M6x1.0. If multiple M6 tapped holes are listed (for example, M6x0.75 and M6x1.0), the first one listed (M6x0.75) will be matched.

In **SOLIDWORKS Tools > Toolbox Settings**, you can also customize size matching using the **Name to Match** column. For example, suppose the last hole you created was a ¼" ANSI inch counterbore hole, and in the **Name to Match** field you entered ¼" or M6. If you then switch to creating DIN counterbore holes, and there is a DIN counterbore hole with M6 in the **Name to Match** field, the hole size for DIN counterbore holes is set to M6.

The **Preserve settings for each Hole Wizard hole type** option is only available when using the Hole Wizard. Advanced Hole and Hole Series use the **Transfer settings when changing Hole Wizard Hole type** option at all times.

String matching is based on the following order of precedence:

IHT is an acronym for Initial Hole Type and FHT is an acronym for Final Hole Type. Special characters are ignored when performing a string in string match.

String 1	String 2	Matching Method
Name to Match column (IHT)	Name to Match column (FHT)	Exact match, for example ¼" or M6 matched to ¼" or M6
Name to Match column (IHT)	Size Column (FHT)	Exact match, for example M6x1.0 matched to M6x1.0
Name to Match column (IHT)	Size Column (FHT)	String in string match, for example M6x0.75 matched to M6
Name to Match column (FHT)	Size Column (IHT)	String in string match, for example M6x0.75 matched to M6
Size column (IHT)	Size Column (FHT)	Exact match, for example M6 matched to M6
Size column (IHT)	Size Column (FHT)	String in string match, for example M6 matched to M6x1
Size column (FHT)	Size Column (IHT)	String in string match, for example M6x1 to M6
Size column (IHT)	Size Column (IHT)	Default to initial value, for example 1/8-27 NPSM matched to #0-80

Mesh BREP Bodies

Mesh BREP (boundary representation) bodies are made up of triangular polygons, called facets. Each facet has three vertices and three edges, referred to as fins.

The facets of a mesh BREP body can be collected into faces. These faces are similar to the faces in standard SOLIDWORKS BREP bodies, except that mesh faces do not have a geometric description. For example, the facets of a mesh face can make up a rectangle, but that face is defined simply as a collection of facets, not as rectangle with a height and width.

Body Types Created from Mesh

You can convert mesh files into three types of bodies:

- Standard SOLIDWORKS BREP bodies
- Mesh BREP bodies
- Graphics bodies

SOLIDWORKS BREP bodies are the standard bodies used in the SOLIDWORKS software. They can be solid or surface bodies. They do not include mesh surfaces. Every point on a face of these bodies can be determined with a mathematical equation.

Mesh BREP bodies can be solid or surface bodies. The bodies are made up of mesh facets. The facets can be grouped into faces. Facets can form a geometric shape such as a rectangle, and the rectangle can have a BREP face associated with it, but not every point on every face can be determined with a mathematical equation.

Graphics bodies are defined entirely by their facets, without reference to equations. For example, what appears to be a circle in a graphics body is actually a large number of triangles, some of whose edges approximate the circumference of a circle. These mesh edges do not actually form a mathematical curve.

Geometry Elements

Mesh body types can include six geometric elements:

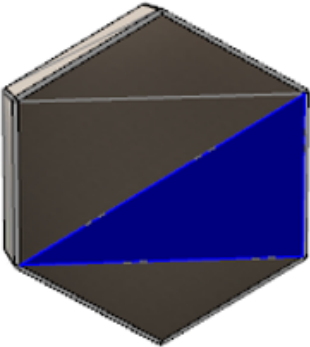
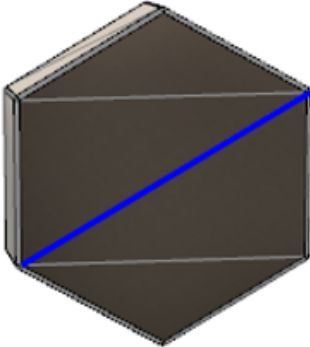
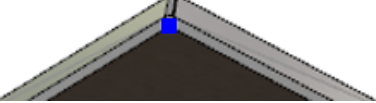
Facets	Triangular faces of each unit of the mesh	
Facet Edges	Edges or fins of the mesh facets	
Facet Vertices	Vertices of mesh facets	

BREP Faces

Faces comprised of mesh facets

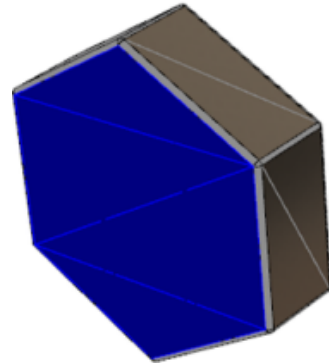

Edges

Boundaries of mesh

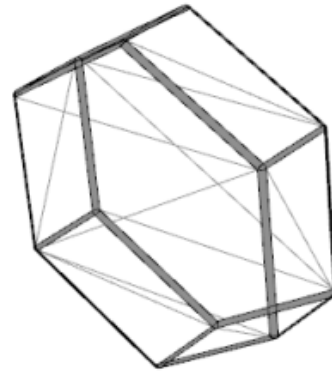

BREP Vertices

Vertices of the edges of mesh BREP faces

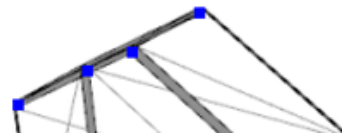

The edges of mesh BREP bodies may approximate mathematical curves, but do not have any geometric attributes.

Workflows for Working with Mesh BREP Bodies

There are three typical methods for working with mesh bodies:

- **Workflow #1**

Import a mesh file (*.stl, *.obj, *.ply, *.ply2, or *.3MF) from a 3-D scanner, a mesh-based modeling software application or another CAD product, and convert it into a mesh BREP body.

- **Workflow #2**

Import a mesh file (*.stl, *.obj, *.ply, *.ply2, or *.3MF) and convert it into a SOLIDWORKS graphics mesh body.

Use the graphics mesh body as a physical or visual reference to design a model. You cannot modify or undo any revisions to a graphics mesh body.

- **Workflow #3**

Select a standard SOLIDWORKS BREP body, or a graphics closed or open body, and convert it to a mesh body. It is recommended that you complete all modifications to the SOLIDWORKS body first and convert it to mesh as the last step in the modeling process.

Working with Mesh

You can manipulate mesh geometry in a similar way as to how you work with SOLIDWORKS geometry and tools such as:

- Determine mass properties.
- Create reference planes for mesh BREP bodies (not graphics bodies).
- Select mesh vertices when sketching. Create sketch relations to a mesh facet vertex of a graphics body or a mesh BREP body.
- Measure distances between mesh elements, using the Measure tool.

You cannot create sensors for mesh bodies.

- Create section views.
- Trim surfaces.
- Shell, offset, and thicken mesh elements.
- Apply appearances and render.
- Detect interference.

Perform Boolean Operations

To combine, intersect, split, move, copy, and cut surfaces, you need to perform these tasks as Boolean operations; that is, create a solid volume before removing geometry.

You cannot combine or perform other Boolean operations on bodies with different geometry types. If you have standard SOLIDWORKS solid or surface bodies, you must convert them to BREP solid or surface bodies with mesh surfaces before performing Boolean operations with other mesh BREP bodies.

Options for Importing Mesh Files

Several system options are available for importing mesh files and converting them to mesh BREP bodies.

To import mesh files:

1. In **Tools > Options > Import**, under **File Format**, select one of the following:
 - **STL/OBJ/OFF/PLY/PLY2**
 - **3MF**
2. Under **Import as**, select one of the following.
 - **Solid Body**
 - **Surface Body**
 - **Graphics Body**

3. Under **Mesh body options**, select one or both of the following for a solid body or surface body:
 - **Create mesh bodies bounded by single faces**
 - **Group facets into faces**
4. Click **OK**.



If you select **Group facets into faces**, the software will attempt to group the mesh facets into selectable faces.

Converting Solid, Surface or Graphics Bodies to Mesh

You can convert a standard SOLIDWORKS body or graphics body to a mesh BREP body using the **Convert to Mesh Body** tool.

Because the tools for editing mesh BREP bodies are limited, you should do as much modeling as possible with the standard SOLIDWORKS BREP body before converting it to a mesh BREP body. After the conversion, you are limited to modifying the mesh BREP bodies using Boolean operations.

To use the Convert to Mesh Body tool:

1. With the standard SOLIDWORKS BREP body or graphic body open, click **Insert** > **Feature** > **Convert to Mesh Body** .
2. For **Selected Bodies** , select solid, surface, graphics closed, or open bodies. You cannot select mixed body types. You can only convert one body type at a time.
3. Make sure **Keep original body** is selected if you want to maintain a reference copy of the original solid or surface body in the model.
4. For graphics bodies, select **Group facets into faces** to group facets into multiple faces. The faces will match the faces of the original standard SOLIDWORKS BREP body. Clear the option if you want to convert the mesh into a single face.

5. Move the **Mesh Refinement** slider toward **Coarse** for fewer, larger facets on the mesh, and toward **Fine**, for more, smaller facets.

A preview of the mesh displays in the graphics area for the selected bodies.

Coarse

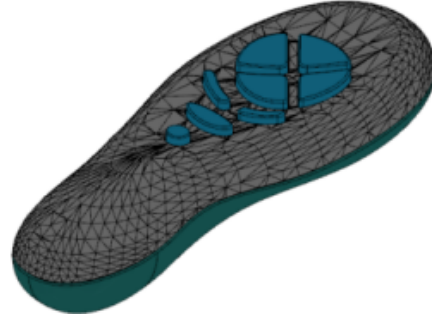

Fine

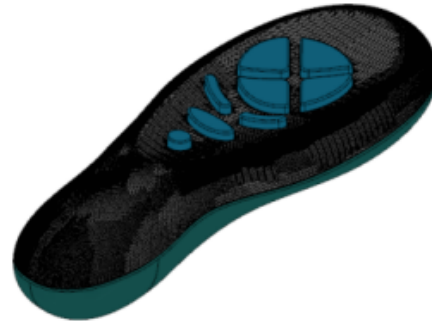

This option is useful if you have two standard SOLIDWORKS BREP bodies of significant different sizes. After you convert the first body to a mesh BREP body with facets of a certain size, you could convert the second standard SOLIDWORKS BREP body to a mesh BREP body, and adjust the mesh refinement, so that the mesh size of the second converted body is close to the mesh size of the first.

6. Instead of using the slider, you can adjust the facets in the mesh by:
 - a) Selecting **Advanced Mesh Refinement** and specifying the **Maximum Distance Deviation** and **Maximum Angle Deviation** of the facets.
 - b) Selecting **Define Maximum Element Size** and specifying the maximum length of the fins.
7. Click .

The **Body-Convert to Mesh Body** feature is added to the FeatureManager design tree.

Selection Filters for Mesh Bodies

The Selection Filter Toolbar lets you select and view the following geometric elements on mesh bodies:

 **Mesh facets**

 **Mesh facet edges**

 **Mesh facet vertices**

Example of filtering mesh facets:

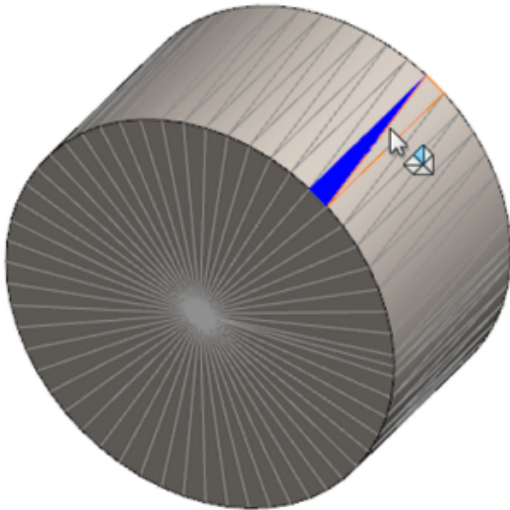

Creating a Surface From Mesh Feature

The **Surface From Mesh** tool lets you manipulate a mesh object that you imported from an *.stl, *.obj, *.off, *.ply, *.ply2 or *.3MF file to create surfaces and solids.

The **Surface From Mesh** tool works best on mesh files with regular prismatic geometry such as planes, cylinders, cones, and spheres. The tool may not be appropriate for highly irregular meshes such as those created from a 3D scan of an organic shape. Because the feature only creates surfaces, the recommended workflow is to trim the surfaces to form a solid.



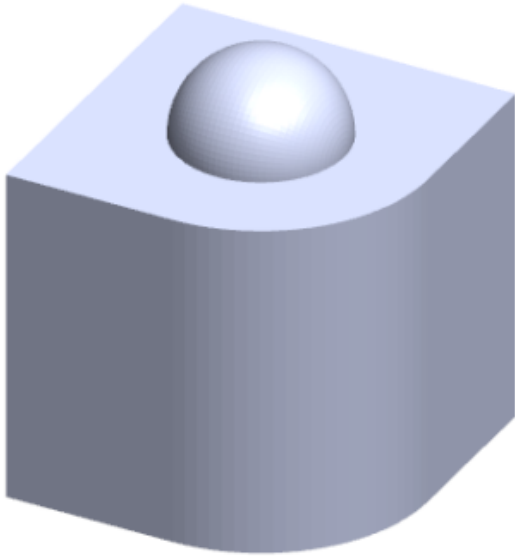

To create a surface from mesh feature:

1. In **Tools > Options > Import**, under **File Format**, select **STL/OBJ/OFF/PLY/PLY2** and click **Import as Graphics Body**. Then click **OK**.

2. Open a file of the format you just selected.



3. Click **Insert** > **Surface** > **Surface From Mesh** .

4. Under **Facets**, do the following:
 - a) Clear **Dynamic Help** if you do not want to display detailed help.
 - b) For surface type, select the type of surface you want to create. You can select either a **Planar** , **Spherical** , **Cylindrical** , or **Conical**  surface.
 - c) In the graphics area, select a group of facets to define the area of the surface you want to create by using the **Paint Select** tool.
 1. Access the tool by right-clicking **Selection Tools** in the graphics area and clicking **Paint Select Facets**.
 2. Press the left mouse button and hold while you drag the pointer and select the facets. The facets that intersect with the **Selection Circle** are highlighted.
 3. Adjust the radius of the **Selection Circle** by moving the slider or clicking the **Up** or **Down** arrow.
 4. To deselect facets, click **ALT + left mouse** button and drag the pointer over the facets you want to remove.
 5. Click  .

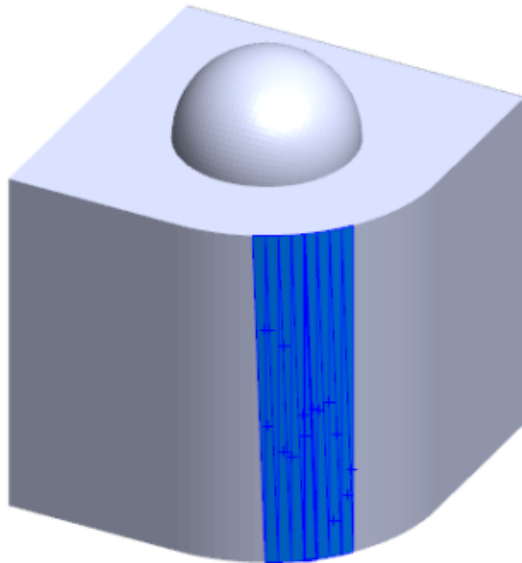

5. Adjust the **Facet tolerance** slider to include fewer mesh facets in the surface you are creating.

Moving the slider left loosens the tolerance for the facets, while moving the slider right tightens the tolerance. For example, if you are attempting to create a plane, and there are three facets, one of which is at a slight angle to the other two, then a loose tolerance will include the angled facet in the plane, while a tight tolerance will exclude it.

6. Use the **Extend surface size**, setting to specify the extension distance of the surface body that fits the selected facets and geometric shape.

7. In the PropertyManager, click **Calculate**.
A preview of the surface body displays in the graphics area.

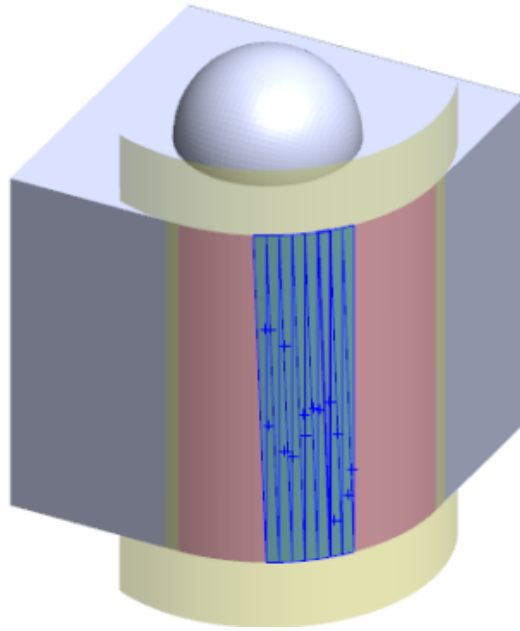

8. Click ✓.
The **Surface-From-Mesh** feature is added to the FeatureManager design tree.

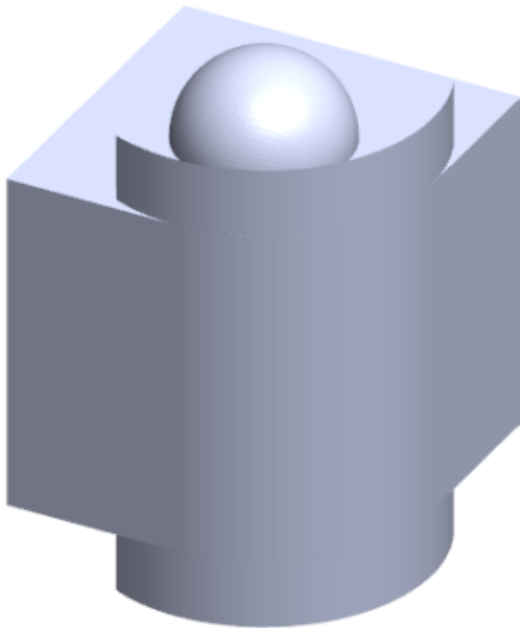

You can continue to trim and knit the surfaces together to form a model.

Selecting Facets Using Paint Select

You can select groups of facets in the graphics area with the Paint Select Tool.

To select facets using paint select:

1. In the graphics area, select a mesh BREP body, right-click **Selection Tools** and click **Paint Select Facets**.
2. Press the left mouse button and hold while you drag the pointer and select the facets. The facets that intersect with the **Selection Circle** are highlighted.

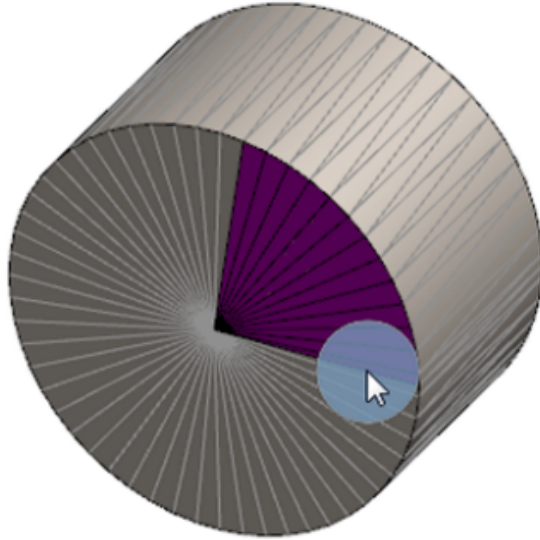

3. Adjust the radius of the **Selection Circle** by moving the slider or clicking the **Up** or **Down** arrow.
4. To deselect facets, click **ALT + left mouse** button and drag the pointer over the facets you want to remove.
5. Click .

List of Features Supporting Mesh BREP Bodies

The following tables list the functionality that supports solid, surface, and graphics mesh BREP bodies.

Solid and Surface Mesh Type

Function Type	Functionality	Notes
Display	Apply an Appearance	Can apply appearance to the face, body, and part.
	Apply a Decal	
	Render in PhotoView	

Function Type	Functionality	Notes
	Section View	
	Supports all display modes (HLR, HLV, wireframe, shaded, shaded with edges)	Facets display shaded in edges mode.
Evaluate	Clearance Detection	Mesh BREP bodies are included in clearance detection for an assembly.
	Interference Detection	Mesh BREP bodies are included in interference detection for an assembly.
	Mass Properties	Facets may change mass properties.
Geometry	Cavity	
	Center of Mass	
	Combine	
	Convert to Mesh	
	Split Line Curve and Project curve	
	Cut with Surface	Applies to solid bodies only.
	Delete Body	
	Delete Face	Only Face option available. Patch and Fill options are not available.
	Extend Surface	Only Distance as end condition and Linear as extension type apply.
	Intersect	
	Isolate in shortcut menu	
	Join	
	Move and Copy Body	Can only use translate. Cannot use constraints to move and copy body.

Function Type	Functionality	Notes
	Offset Surface	Resulting surface is mesh BREP.
	Reference Plane	Supports mesh facets, facet vertices, and facet fins.
	Save Bodies	
	Scale	
	Shell	
	Split	
	Split Line	
	Surface From Mesh	
	Thicken	Applies to surface only.
	Trim Surface	Applies to surface only.
Sketch	Reference mesh BREP vertex in sketch	
	Sketch Relations	Ability to create coincident constraints for a sketch point by selecting a mesh edge or vertex. Mesh edges represent a sharp edge (created from groups of fins) and mesh vertex is a sharp vertex; that is, corner vertices from a combination of sharp edges. You cannot inference mesh facet faces and mesh fins in sketch commands. Also, you cannot use them to add sketch relations.

Graphics Mesh Type

Function Type	Functionality	Notes
Display	Apply an Appearance	Can only apply appearance to the body or part.

Function Type	Functionality	Notes
	Render in PhotoView	Renders only in HLR/Wire frame in draft quality.
	Section View	Can only use a graphics section.
	Supports all display modes (HLR, HLV, wireframe, shaded, and shaded with edges)	
Geometry	Convert to Mesh	
	Delete	Delete Body is not supported.
	Move and Copy Body	Can only use translate. Cannot use constraints to move and copy body.
	Surface From Mesh	
Sketch	Reference graphics mesh vertices in a sketch	

Enhancements to Importing Mesh Files as Graphics Bodies

When you import mesh files as graphics bodies, the SOLIDWORKS software now supports additional features.

- You can apply texture and appearances to mesh files that you import into SOLIDWORKS as graphics bodies.
- The imported graphics bodies are visible when you view them in HLR, HLV, and wireframe modes.
- The SOLIDWORKS software can render the imported graphics bodies along with solid and surface bodies.
- The imported graphics bodies can appear behind other geometry. Previously, they always appeared in the foreground even if the other geometry should have been displayed in front of the graphics bodies.
- Imported `.3MF` files that contain meshes with textures and appearances display the texture and appearances on the imported graphics bodies.

More Control Over Custom Properties

You have more control over custom properties and cut list properties.

This functionality is available only when the part is created in SOLIDWORKS 2018.

Adding an @ Sign Before Quotation Marks

When you define a custom file property or cut list property that includes a single or double quotation mark (' or "), type an @ sign in front of the quotation mark to ensure that the expression evaluates correctly.

The @ sign is required when the expression for the custom property includes a quotation mark to indicate inches, or references the name of a dimension, feature, sketch, cut list folder, weldment profile, annotation, bill of materials, or other entity that includes a quotation mark.

To add an @ sign before quotation marks:

1. In a part file, open the Cut List Properties dialog box by doing the following:
 - a) In the FeatureManager design tree, expand **Cut list**.
 - b) Right-click a cut list item and select **Properties**.
2. In the **Cut List Summary** tab, ensure that the top check box in the **Linked** column is clear.

The **Link**  column lets you select properties where the values and text in **Value/Text Expression** are linked to a parent part or a cut list folder.

When the check boxes in the **Linked** column are clear, the values for **Value/Text Expression** become editable.

3. In **Value/Text Expression**, type an @ sign before each quotation mark, for example, 2@" X 2@" X 1/4@" and press **Enter**.

The correct value appears in **Evaluated Value**.

Value / Text Expression	Evaluated Value
"LENGTH@@@TUBE, SQUARE 2@" X 2@" X 1/4@" <1>@	1'- 7/8"
"ANGLE1@@@TUBE, SQUARE 2@" X 2@" X 1/4@" <1>@	45°
"ANGLE2@@@TUBE, SQUARE 2@" X 2@" X 1/4@" <1>@	45°

The @ sign also applies when referencing a **Property Name** that includes a quotation mark. For example, if you have a file property whose name is Length12", you must add an @ sign in **Value/Text Expression** for that property.

Unlinking and Relinking Properties to a Parent Part

In the Custom Property dialog box, a new **Link**  column lets you select properties where the text in **Value/Text Expression** can link to a parent part or a cut list folder. If the box in the **Link** column is clear, you can override the value in **Value/Text Expression**.

You can unlink one property at a time by clearing the link box for that property. You can also unlink all custom properties for a derived part by clearing the box at the top of the **Link** column  and then enter new values for all properties.

The same logic applies to relinking. You can relink one property or all properties to the parent part. If the parent part is open, SOLIDWORKS automatically updates the **Value/Text Expression** with the value from the parent part.

If the parent part is not open when you relink the property, an (*) asterisk displays in the **Evaluated Value**, and a message, such as

*Calculated the next time the base part is opened

appears at the bottom of the dialog box. When you open the parent part again, the value updates and the message disappears.

In the **External References** dialog box, if **Break All** for the parent part is selected, then all links in a derived part are grayed out. You can enter new values for all properties, but you cannot relink properties to a parent part.

21

SOLIDWORKS Manage

This chapter includes the following topics:

- **SOLIDWORKS Manage Overview**
- **Project Management**
- **Process Management**
- **Item Management**
- **Dashboards and Reports**

SOLIDWORKS Manage Overview

SOLIDWORKS Manage is an advanced data management system that extends the global file management and application integrations enabled by SOLIDWORKS PDM Professional.

SOLIDWORKS Manage is the key element in providing Distributed Data Management. This is accomplished by various functional areas:

- Project management
- Process management
- Item management
- Dashboards and reports

Project Management

Project management provides information to help people focus on tasks and provides an overview of resource capacity for better planning and usage.

With project management, you can:

- Manage project stages, timelines, and milestones
- View resource usage and capacity
- Attach items and files and list deliverables
- Track progress with user tasks and timesheets

Process Management

Process management streamlines business processes and automates document creation. It also showcases new products to all involved stakeholders, from sales and marketing to production and support.

With process management, you can:

- Configure states and decision points for business processes
- Attach affected items and files
- Enable ad hoc approvers and user tasks

Item Management

Item management brings together all components required for product definition, whether represented by CAD models, documents, or items.

With item management, you can:

- Create, edit, and compare bills of materials (BOMs) using items and files
- Automatically or selectively create items for configurations in the SOLIDWORKS software
- Drive SOLIDWORKS drawing BOMs and item numbers

Dashboards and Reports

Dashboards and reports provide instant access to information in a readable format for better decision making.

With dashboards and reports, you can:

- Create interactive graphical dashboards to display critical information
- Configure reports to company standards and publish automatically or manually

22

SOLIDWORKS PCB

This chapter includes the following topics:

- **Adding Hardware to SOLIDWORKS CAD**
- **Component Movement in 3D CAD**
- **CST Integration**
- **IPC-Compliant Footprint Wizard**
- **DB Link**
- **PCB Services HTTPS Support**
- **Positioning Embedded Components**
- **Symbol Wizard**
- **Variant Collaboration**

SOLIDWORKS PCB is available as a separately purchased product.

Adding Hardware to SOLIDWORKS CAD

You can add hardware (heat sinks, rails, and stiffeners) in the SOLIDWORKS software and push the hardware to SOLIDWORKS PCB using the SOLIDWORKS PCB Connector.

Component Movement in 3D CAD

Enhancements to SOLIDWORKS PCB eliminate potential ECAD data integrity issues during collaboration.

The Z-axis cannot change when you move components in the SOLIDWORKS software. Parts are mated to the surface of the board when moved, which eliminates the possibility to move a part above, below, or into a board.

If you move components with through holes, the hole locations update in SOLIDWORKS.

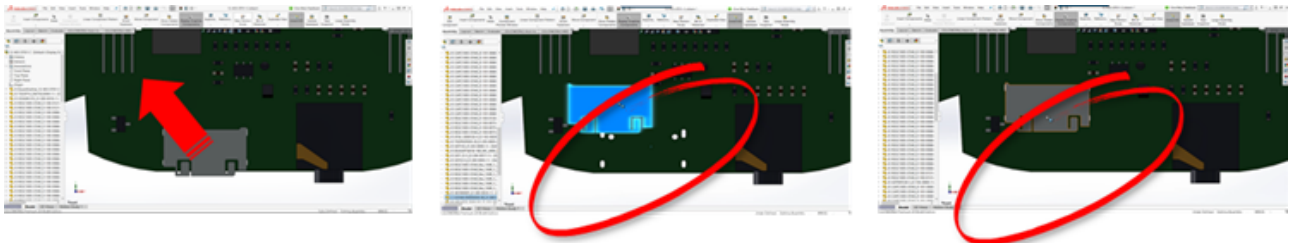

CST Integration

There is support to enable CST Integration through odb++ output.

IPC-Compliant Footprint Wizard

You can create IPC-compliant PCB footprints in a wizard. The set of productivity tools streamlines and automates footprint creation.

With the wizard, you can automatically generate footprints from dimension information according to IPC package standards. The wizard is based on formulas from the IPC-7351 standard.

DB Link

The DB link ensures component data integrity by using properties from an approved corporate database.

You can connect SOLIDWORKS PCB schematic parts to engineering or corporate databases of component and parametric data, such as:

- Procurement data
- Electrical parameters
- Device documentation

You can also transfer mapped information from database records to design component parameters.

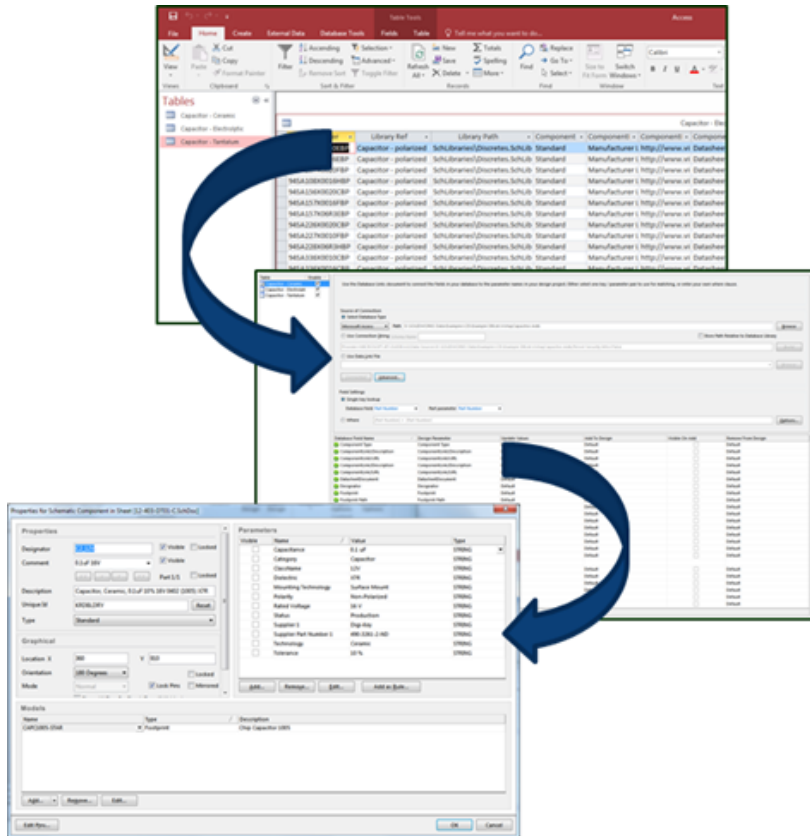

PCB Services HTTPS Support

There is an additional layer of security for exchanging ECAD-MCAD data with SOLIDWORKS PCB Services.

SOLIDWORKS PCB Services has secure communication over networks using HTTPS protocol to protect data privacy and integrity. You can also install SOLIDWORKS PCB Services on a secure server.

Positioning Embedded Components

SOLIDWORKS PCB supports the correct positioning of embedded components when pushed from Altium Designer® to the SOLIDWORKS software through the SOLIDWORKS PCB Connector.

Symbol Wizard

The symbol wizard has productivity tools to streamline and automate symbol creation.

The symbol wizard:

- Simplifies and quickens the symbol creation process, especially for large schematic devices.
- Is configured using grid-based, tabular data.
- Allows for copy, paste, and smart paste operations.

Variant Collaboration

You can align variations of electronic and mechanical base designs for a more accurate representation of form and fit.

SOLIDWORKS PCB Variants are expressed as configurations in the SOLIDWORKS software. Components marked as **Not installed** are suppressed.

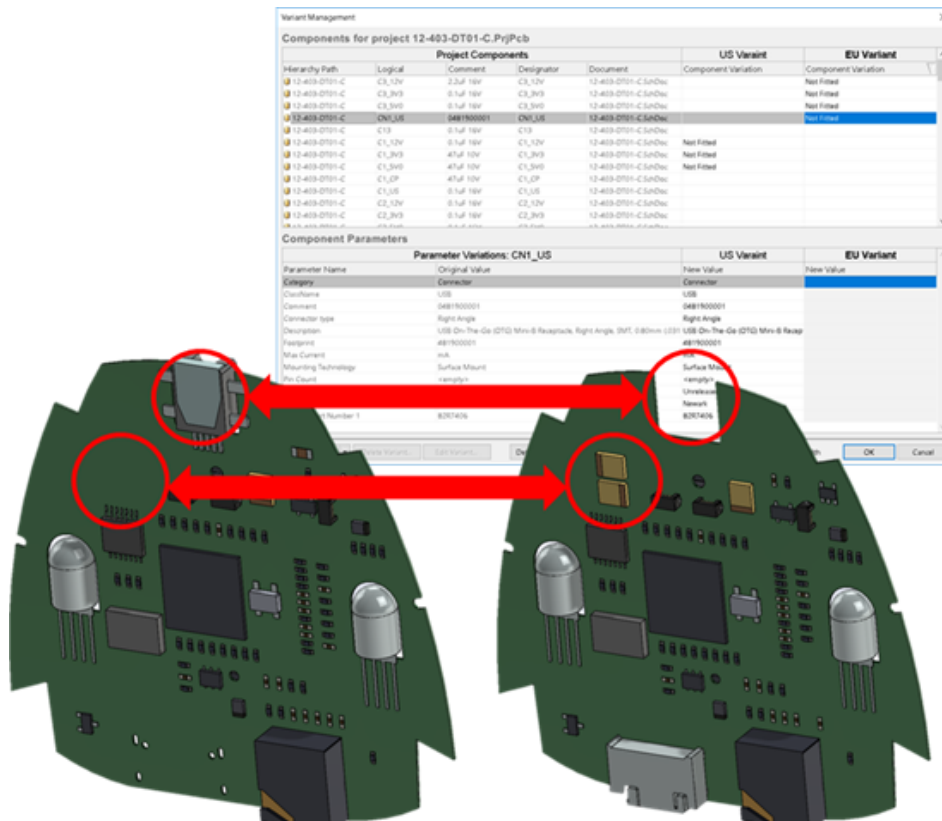

23

SOLIDWORKS PDM

This chapter includes the following topics:

- **Automated Drawing PDF Creation in SOLIDWORKS PDM Standard**
- **Data Card Editor Undo**
- **Design Branching and Merging**
- **Detailed Warning Messages**
- **Enhanced Assignment of Explicit Folder Permission**
- **Enhanced File Version Upgrade Tool**
- **Enhanced Permission Control**
- **Quality Enhancements in SOLIDWORKS PDM**
- **Revision Table Integration**
- **Setting Dynamic Variable Values in Copy Tree**
- **SOLIDWORKS PDM Application Programming Interface**
- **SOLIDWORKS PDM Support for Non-SOLIDWORKS CAD File References**

SOLIDWORKS® PDM is offered in two versions. SOLIDWORKS PDM Standard is included with SOLIDWORKS Professional and SOLIDWORKS Premium, and is available as a separately purchased license for non-SOLIDWORKS users. It offers standard data management capabilities for a small number of users.

SOLIDWORKS PDM Professional is a full featured data management solution for a small and large number of users, and is available as a separately purchased product.

Automated Drawing PDF Creation in SOLIDWORKS PDM Standard

SOLIDWORKS PDM Standard can convert a SOLIDWORKS Drawing file to PDF during a workflow transition using the same task technology used in SOLIDWORKS PDM Professional.

To provide access to the **Convert** task, you must add it to the vault by:

- Selecting the task when you create a new vault.
- Importing the task into an existing vault.

Configuring the Convert Task (For SOLIDWORKS PDM Standard only)

Administrators can configure the Drawing to PDF Convert task provided by the SOLIDWORKS Task Add-in to convert a SOLIDWORKS Drawing file to PDF. The task can map data card variables, and set the naming convention and destination for converted files.

To configure the Drawing to PDF Convert task:

1. In the Administration tool, expand **Tasks** and double-click **Convert**.
2. In the dialog box, in the left pane, click **Execution Method**.
3. Select the client computers that can be used to execute the task and how task execution is initiated.

You must configure each client computer as a task host to appear in the list and run the Drawing to PDF Convert task on the computer where you initiate the workflow transition.

Each client computer must have a licensed version of SOLIDWORKS to initiate the task.

4. Click **Conversion Settings > Conversion Options** to display the output file format's Advanced Conversion Options (Adobe PDF) dialog box.
The only output file format available is Adobe PDF (default).
5. Under **Source file references**, specify the version of referenced files to convert.
6. Click **File Card** to map variables from the source file's data card to the output file's data card.
7. Click **Output File Details** to specify the output file name format and destination.
You can specify only the output paths that are inside the vault.
8. Click **OK**.

Converting a SOLIDWORKS Drawing File to PDF

To convert a SOLIDWORKS Drawing file to PDF:

1. In the Administration tool, configure the Convert task.
2. Edit a workflow transition to add an action to execute the Drawing to PDF Convert task.

When you change the state of a SOLIDWORKS Drawing file using a transition on which the Drawing to PDF Convert task is set, SOLIDWORKS PDM runs the task. The task:

- a. Launches a SOLIDWORKS session on the client computer.
- b. Opens the SOLIDWORKS Drawing file.
- c. Saves the file as PDF.

Data Card Editor Undo

SOLIDWORKS PDM lets you undo the changes done in the Card Editor for an active card. Previously, to undo the changes, you had to close and reopen the card without saving.

To undo the card editor changes, do one of the following:

- Click **Edit > Undo**.
- Click **Undo** in the Main toolbar.
- **Ctrl + Z**.

You can undo the data card changes only if you have not saved the changes.

SOLIDWORKS PDM supports undo for:

- Modifying cards using control properties and card properties.
- Adding and deleting card controls.
- Moving and resizing card controls.

You cannot redo the data card changes that Undo discards.

Design Branching and Merging

SOLIDWORKS PDM Professional has improved handling of various design change scenarios including multiple design improvement approaches, engineering change requests, and working with external design consultants.

Branching an existing file structure is similar to Copy Tree, but SOLIDWORKS PDM Professional maintains the history of source files and branched files. You can create new versions of the source files from the modified versions of branched files regardless of whether they have been moved or renamed.

History on tool vise.SLDASM				
Event	Ver...	User	Date	Comment
Initial transit...	1	Ad...	2017...	State changed by automatic transition.
Branched 'br1'	1	Ad...	2017...	Branched From C:\Vault_631\Tool Vise\tool vise.SLDASM
Created	1	Ad...	2017...	

History of branched file

History on tool vise.SLDASM				
Event	Ver...	User	Date	Comment
Branched 'br1'	1	Ad...	2017...	Branched To C:\Vault_631\Branching\tool vise.SLDASM
Initial transit...	1	Ad...	2017...	State changed by automatic transition.
Created	1	Ad...	2017...	

History of source file

Branching functionality lets you create complete or partial copies of a file structure with different names and place them in one or more folders. Placing the files into multiple folders lets you edit the branched files, retaining the source files in their original state and permission status. If the edits are approved, you can create new versions of the source files. Otherwise, you can delete the branched files.

Branching Settings

You can branch a single file or a file with its references. After branching, the source file history and branched file history are updated.

Administrators can also set user and group properties to exclude selected folders from branching. The files in the excluded folders are not available for branching.

In the Administration tool, on the Settings - Branch page, you can select the following predefined variables from the list to update the variable values.

Branch File Name
Branch File Name without extension
Branch File Path
Branch Name
Current time
Logged in user
Source File name
Source File name without extension
Source File path
Today's date
User - Full name
User - initials
User - User data

In the file list, right-click a branched file and select **Associated Branches** to list all the branches the file is a part of. Click a branch from the list to see the branch details.

Branch Dialog Box

The Branch dialog box is similar to the Copy Tree dialog box and lets you copy selected file references, or retain the existing references.

If your administrator has excluded a folder from branching, a message appears in the **Warnings** column and the **Branch** option is unavailable.

To display the Branch dialog box:

- Select a file and click **Tools > Branch**.

Branch Name

Enter a branch name.

You must enter a unique branch name.

Default Destination

Displays the current folder location of the selected file. You can enter a new path or browse to specify the destination path for the folder in the vault.

Settings

This group is a collapsible interface that includes:

Version to Use

Latest

Uses the latest version of the references for branching.

Referenced

Uses the attached version of the references for branching.

Options

Include simulation

Branches SOLIDWORKS Simulation results associated with the selected files.

Preserve relative paths

Keeps the paths of references relative to the branched parent file, creating a folder structure as needed. When you clear **Preserve relative paths**, the folder hierarchy is flattened and all referenced files are branched to the same destination folder as the parent.

Include drawings

Shows any related drawing files in the file list so you can include them when branching the reference tree.

Regenerate serial number in cards

If serial numbers are used in data cards, assigns the next number in the sequence. For **Rename with serial number** transformations, the same serial numbers used to name the files are used in data cards.

Name drawings after their models

Sets drawing file names to the same as their associated assembly or part file names.

Transform Operations Modifies the file names of selected files using the transformation you select.

Add Prefix

Adds the prefix you type to the file names.

Add Suffix

Adds the suffix you type to the file names.

Rename with serial number

Replaces file names with serial numbers.

Only available when serial numbers are defined in the Administration tool.

Replace

Replaces strings in file or folder names. In the Replace dialog box:

1. For **Find what**, type the string to replace.
 2. For **Replace with**, type the replacement string.
 3. Select whether to apply the change to all files or only the selected files.
 4. Select to apply the change to file names, folder names, or both.
-

Filter Display

Enter text to refine the list of files displayed. Use the column selection drop-down to limit the filtering to a specific column. For example, limit the columns to **File name**, or **All Columns**.

By default, the filter is applied to **All Columns**. You can expand the **All Columns** list and select a specific column to apply the filter to. The software searches for the text that you enter, displays rows that contain the text, and highlights the text for identification.

The search field supports these wildcard characters: *, ?, %, -, ., "".

*string

Displays rows that contain text that ends with the entered string. The string in the filtered rows is highlighted in pink.

string*

Displays rows that contain text that starts with the entered string. The string in the filtered rows is highlighted in pink.

Instead of *, you can use ? or %.

<code>-string or string-</code>	Displays rows that contain the entered string. <div style="border: 1px solid black; padding: 5px; margin-top: 10px;">If the hyphen is at the beginning, the text ending with the string is highlighted in pink. If the hyphen is at the end, the text starting with the string is highlighted.</div>
<code>"string or string"</code>	Displays rows that contain the entered string. The string in the filtered rows is highlighted in pink.
<code>.string or string.</code>	Displays rows that contain the entered string and highlights the string with a preceding or a succeeding character depending on the position of the dot.

The filter options include:

Invert Filter or !	You can invert the filter by clicking or by entering the ! character as a prefix to the text in the search field. Files that do not include the entered text are displayed.
---------------------------	--

Filter	<ul style="list-style-type: none">• File Type<ul style="list-style-type: none">• Assemblies• Parts• Drawings• Others• Selected For Branch<ul style="list-style-type: none">• Yes, Selected• No, Not Selected• Path/Name Changed<ul style="list-style-type: none">• Yes, Changed• No, Not Changed
---------------	--

All Columns

Filters the file list based on the text you enter and the column you select. You can select one of the following columns:

- **Source File Name**
- **Warnings**
- **Version**
- **Checked Out By**
- **Checked Out In**
- **Source File Found In**
- **Branch File Found In**
- **Branch File Name**
- **State**
- **All Columns**

This filter supports all custom columns that appear in the file list.

Clear Filter Text 

Removes all filters. This appears when you select an option in **Filter**.

Toolbar Buttons

**Next
Warning/Previous
Warning**

In the file list, changes the focus to the next file with a warning or the previous file with a warning.

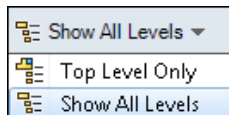
**Levels**

Displays file references for the entire file hierarchy (**Show All Levels**) or just the top level of the file hierarchy (**Top Level Only**).

The setting defaults to the most recent setting you used.

**Open File List**

Open All opens a list of files in Microsoft Excel.

Open Visible opens a list of visible files in Microsoft Excel.

**Save File List**

Export All exports the file list of all files as comma-separated `.txt` file.

Export Visible exports the list of visible files as a comma-separated `.txt` file.

File List

To change the columns that are displayed, right-click any column heading and select columns to display them or clear columns to hide them. You can add up to 10 columns based on variables by clicking **More** and choosing variables from the Choose Columns dialog box.

You can sort the default and custom columns in tables in ascending, descending, or default order by clicking column headers. Column sorting is useful within large datasets. If you sort a column in ascending or descending order, the column is highlighted in green and an arrowhead appears. When you sort a column in a table, SOLIDWORKS PDM removes the file structure hierarchy. Sorting turns off **Show Tree Lines** and **Show Reference Selection Control**.

Drag a column head to change the position of a column.

Type	Displays a thumbnail preview of the file when you hover over the file type icon.
Source File Name	Displays the source file name.
Warnings	Displays the warnings. <div style="border: 1px solid gray; padding: 5px; margin-top: 10px;"> <p>To quickly locate files with warnings or errors, use the Next Warning ⚠️↓ and Previous Warning ⚠️↑ toolbar buttons or Ctrl + the up-arrow or down-arrow on the numeric keypad.</p> </div>
Branch	Lets you select the files to branch.
Version	The first number is the local (cached) version of a source file or a hyphen (-) if locally modified. The second number is the latest version in the vault.
Checked Out By	User who has the source file checked out, or blank if not checked out.
Checked Out In	Path to computer and local folder where the source file is checked out, or blank if not checked out.
Source File Found In	Path to the folder that contains the source file.
Branch File Found In	Lets you change the path to a folder for the branched file. <div style="border: 1px solid gray; padding: 5px; margin-top: 10px;"> <p>The folder must be in the vault.</p> </div>
Branch File Name	Lets you change the branched file name.
State	State of the source file.

Check-in after branching

Checks in files on branching.
You can optionally enter the check-in comments.

Total to Branch

Displays the number and type of files you have selected for branching.

The warning  indicates that other files are selected for branching but do not appear in the file list because of the current filter.

Reset All

Resets all the changed file names and changed destination folder paths to default.

Merging Settings

In the Administration tool, on the Settings - Merge page, you can select the following predefined variables from the list to update the variable values.

Branch File Name
Branch File Name without extension
Branch File Path
Current time
Logged in user
Source File name
Source File name without extension
Source File path
Today's date
Use from Branch File
Use from Source File
User - Full name
User - initials
User - User data

Merge Dialog Box

The **Merge** dialog box lets you merge the branched file with the source file using different merging options.

To display the Merge dialog box:

- Select a branched file and click **Tools > Merge**.

Settings

Branch References	<hr/> Latest Uses the latest version of the branched file for merging. <hr/> Referenced Uses the attached version of the branched file for merging. <hr/>
New File Options	Applicable for files that are newly created using merge option. <hr/> Include simulation Merges SOLIDWORKS Simulation results associated with the selected files. <hr/> Include drawings Shows any related drawing files in the file list so you can include them when merging the reference tree. <hr/> Regenerate serial number in cards If serial numbers are used in data cards, assigns the next number in the sequence. For Rename with serial number transformations, the same serial numbers used to name the files are used in data cards. <hr/> Name drawings after their models Sets drawing file names to the same as their associated assembly or part file names. <hr/>

Transform Operations Modifies the file names of selected files using the transformation you select. Applicable for files that are newly created using merge option.

Add Prefix

Adds the prefix you type to the file names.

Add Suffix

Adds the suffix you type to the file names.

Rename with serial number

Replaces file names with serial numbers.

Only available when serial numbers have been defined in the Administration tool.

Replace

Replaces strings in file or folder names. In the Replace dialog box:

1. For **Find what**, type the string to replace.
 2. For **Replace with**, type the replacement string.
 3. Select whether to apply the change to all files or only the selected files.
 4. Select to apply the change to file names, folder names, or both.
-

Filter Display

Lets you enter text to refine the list of files displayed. A column selection drop-down lets you limit the filtering to a specific column, for example, **File name**, or for **All Columns**.

By default, the filter is applied to **All Columns**. You can expand the **All Columns** list and select a specific column to apply the filter to. The software searches for the text that you enter, displays rows that contain the text, and highlights the text for easy identification.

The search field supports these wildcard characters: *, ?, %, -, ., "".

*string

Displays rows that contain text that ends with the string. The string in the filtered rows is highlighted in pink.

string*

Displays rows that contain text that starts with the string. The string in the filtered rows is highlighted in pink.

Instead of *, you can use ? or %.

<code>-string or string-</code>	Displays rows that contain the string. <div style="border: 1px solid black; padding: 5px; margin-top: 10px;">If the hyphen is at the beginning, the text ending with the string is highlighted in pink. If the hyphen is at the end, the text starting with the string is highlighted.</div>
<code>"string or string"</code>	Displays rows that contain the string. The string in the filtered rows is highlighted in pink.
<code>.string or string.</code>	Displays rows that contain the string and highlights the string with a preceding or a succeeding character depending on the position of the dot.

The filter options include:

!	You can invert the filter by entering character ! as a prefix to the text in the search field. Files that do not include the entered text are displayed.
---	---

Filter	<ul style="list-style-type: none">• File Type<ul style="list-style-type: none">• Assemblies• Parts• Drawings• Others• Selected For Merge<ul style="list-style-type: none">• Yes, Selected• No, Not Selected• Path/Name Changed<ul style="list-style-type: none">• Yes, Changed• No, Not Changed
---------------	---

All Columns

Filters the file list based on the text you enter and the column you select. You can select one of the following columns:

- **Branch File Name**
- **Branch File Version**
- **Branch File Found In**
- **Branch File Checked Out By**
- **Branch File Checked Out In**
- **Branch File State**
- **Warnings**
- **Merge**
- **Merge Option**
- **Source File Name**
- **Source File Found In**
- **Source File Checked Out By**
- **Source File Checked Out In**

This filter supports all custom columns that appear in the file list.

Clear Filter Text 

Removes all filters. This appears when you select an option in **Filter**.

Toolbar Buttons

**Next Warning/Previous Warning**

In the file list, changes the focus to the next file with a warning or the previous file with a warning.

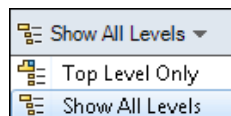
**Levels**

Displays file references for the entire file hierarchy (**Show All Levels**) or just the top level of the file hierarchy (**Top Level Only**).

The setting defaults to the most recent setting you used.

**Open File List**

Open All opens a list of files in Microsoft Excel.

Open Visible opens a list of visible files in Microsoft Excel.

**Save File List**

Export All exports the file list of all files as comma-separated .txt file.

Export Visible exports the list of visible files as a comma-separated .txt file.

File List

To change the columns that are displayed, right-click any column heading and select columns to display them or clear columns to hide them. You can add up to 10 columns based on variables by clicking **More** and choosing variables from the Choose Columns dialog box.

You can sort the default and custom columns in tables in ascending, descending, or default order by clicking column headers. Column sorting is useful within large datasets. If you sort a column in ascending or descending order, the column is highlighted in green and an arrowhead appears. When you sort a column in a table, SOLIDWORKS PDM removes the file structure hierarchy. Sorting turns off **Show Tree Lines** and **Show Reference Selection Control**.

Drag a column head to change the position of a column.

Type	Displays a thumbnail preview of the file when you hover over the file type icon.
Branch File Name	Displays the branched file name and its references.
Branch File Version	The first number is the local (cached) version of a branched file or a hyphen (-) if locally modified. The second number is the latest version in the vault.
Branch File Found In	Path to the folder that contains the branched file.
Branch File Checked Out By	User who has the branched file checked out, or blank if not checked out.
Branch File Checked Out In	Path to computer and local folder where the branched file is checked out, or blank if not checked out.
Branch File State	State of the branched file.
Warnings	<p>Displays the warnings  specific to source files and branched files. For multiple warnings for a file, a hyperlink appears. You can click the link to see the details of the warnings.</p> <div style="border: 1px solid gray; padding: 5px; margin: 5px 0;"> <p>To quickly locate files with warnings or errors, use the Next Warning and Previous Warning toolbar buttons or Ctrl + the up-arrow or down-arrow on the numeric keypad.</p> </div> <div style="border: 1px solid yellow; padding: 5px; margin: 5px 0; background-color: #ffff00;"> <p>You can complete the merge action only after you resolve the critical warnings.</p> </div>
Merge	<p>Lets you select files to merge.</p> <p>If the Merge check box is not selected for a file, the references from the branched file are retained as they are, after the merge action.</p>

Merge Option

Merge

Selected by default for the branched file that is modified. Creates a new version of a source file when a branched file is checked in through the Merge user interface. You can keep the file checked out and check it in later.

You must have read file permission and check out file permission for the source file.

Use Source Reference

Selected by default for the unmodified branched file only if its immediate parent file is selected to merge. SOLIDWORKS PDM reprints the reference to the source file after the merge action.

If **Always work with the latest version of files** is selected, SOLIDWORKS PDM reprints the reference to the latest version of the source file. You must have read file permission for the latest version.

If **Always work with the latest version of files** is cleared, the merge action reprints the reference to the version of the source file that is used during branching.

If this version is not available or in cold storage, or does not provide read access, the merge action reprints the reference to the latest version that has read-file permission.

Merge As New File

Available for a branched file. The parent file refers to the new file after the merge action. You must have the add or rename file permission for the vault folder that contains the new file.

By default, the Source File Name is the name of the branched file and its target location is the parent file location. You can change the file name and its target location.

Create New File

Available for the file that is not branched but is a part of the reference tree. You must have the add or rename file permission for the vault folder that contains the new file. The parent file refers to the new file after the merge action.

By default, the Source File Name is the name of the branched file and its target location is the parent file location. You can change the file name and its target location.

Source File Name

Lets you change the source file name only if the **Merge Option** is set to **Merge As New File** or **Create New File**.

Source File Found In	Lets you change the path to the vault folder that contains the source file only if the Merge Option is set to Merge As New File or Create New File .
Source File Checked Out By	User who has the source file checked out, or blank if not checked out.
Source File Checked Out In	Path to folder where the source file is checked out, or blank if not checked out.
Source File State	State of the source file.

Check-in on Merge

Checks in files on merging.
You can optionally enter the check-in comments.

Total to Merge

Displays the number and type of files you have selected for branching.

The warning indicates that other files are selected for branching but do not appear in the file list because of the current filter.

Reset All

Resets all the changed file names and changed destination folder paths to default.

Detailed Warning Messages

SOLIDWORKS PDM now provides more-detailed warning messages when a transition fails.

If one or more conditions are not met, the **Warnings** column displays:

- A warning in case of one failed condition.
- A hyperlink in case of multiple failed conditions or all failed OR conditions.

You can click the hyperlink to see the details of the conditions that are not met. Based on the conditions defined in the transition, the warning includes details like condition type, comparison criteria, value, and configuration details.

Enhanced Assignment of Explicit Folder Permission

SOLIDWORKS PDM lets you set explicit folder permissions on multiple folders at the same time.

Previously, you could set explicit permissions on one selected folder at a time.

On the Assigned Folder Permissions tab, to select multiple folders, do one of the following:

- **Shift** + click
- **Ctrl** + select
- Left-drag

The **Folder Permissions** area displays the assignable permissions. The status of check box changes as the folder permission assigned to selected folder changes.

Check box status	Description
<input checked="" type="checkbox"/> (Selected)	Permission is set to all selected folders.
<input type="checkbox"/> (Green)	Permission is set to one or more selected folders, but not all.
<input type="checkbox"/> (Cleared)	Permission is not set to any selected folder.

Enhanced File Version Upgrade Tool

In the SOLIDWORKS PDM File Version Upgrade tool, vault analysis and upgrade are now quicker.

The enhancements in the upgrade tool let you:

- Upgrade the checked out files on other client workstations.
- Add or remove folders to upgrade.
- Sort the file list in Search Results.
- Stop the upgrade process and resume.
- View the summary of the file versions to upgrade.
- Monitor the upgrade process.
- Notify users about the upgrade process.

Upgrade Tool Behavior for Checked out Files

You can upgrade the checked out file and its references if the file is checked out on a machine other than the host machine.

You can upgrade the checked out file when:

- Creating new versions of files

- Overwriting existing versions of files

The following table describes the file handling of checked out file and its references:

Option	Action on checked out file	Action on parent references	Action on child references
Create new versions of files	Skip the file	Upgrade the latest version of the parent file	Upgrade the latest version of the child references
Overwrite existing versions of files	Upgrade all versions of the file	Upgrade all versions of the parent file	Upgrade all versions of the child references

You cannot upgrade the checked out file and its references if the file is checked out on the host machine.

When using **Overwrite existing versions of files** option, the upgrade tool does not check out the file, and the file is accessible to other users.

File Version Upgrade Summary

The upgrade tool shows the summary of the file versions to upgrade on the Ready to Upgrade Files screen.

The summary displays the following:

- Total number of SOLIDWORKS versions to update.
- Number of SOLIDWORKS part file versions.
- Number of SOLIDWORKS drawing file versions.
- Number of SOLIDWORKS assemblies file versions.
- Work instruction file names.
- Number of files in each work instruction file.

Monitoring the Upgrade Process

To monitor the upgrade process, do one of the following:

- On the Welcome screen, click **Monitor upgrade process**.
- Initiate the upgrade process and, on the Ready to Upgrade Files screen, click **Monitor**.

The Monitor upgrade screen displays the overall upgrade process progress and the upgrade progress of each work instruction file.

Host Name	Machine name on which you initiate the upgrade process
Instruction file name	Names of the work instruction files
Progress	Upgrade completion status of work instruction files

Processed Batch	Number of processed batches / total number of batches
Processed File	Number of processed files / total number of files
Start time	Time when the upgrade process is started
Elapsed time	Time elapsed after the upgrade is started
Status	Upgrade status of work instruction files

Notifying Users About the Upgrade Process

SOLIDWORKS PDM notifies users whenever the upgrade process is started, paused, resumed, completed, or has failed.

To notify users about the upgrade process:

1. On the Upgrade Settings screen, select **Notify success/failure to users**.
2. Click **Add** and select the users to be notified.
SOLIDWORKS PDM sends notification emails to the designated users based on the status of work instruction files.

Enhanced Permission Control

The Admin user can allow users to undo check out or check in the files that are checked out by another user.

The administrative permission, **Can undo check out files checked out by other users**, is selected by default for the Admin user.



With this permission, users can do the following to the files checked out by other users:

- Undo the Check out or Check in of files on the same machine and in the same vault view.
- Undo the Check out of files on a different machine and in a different vault view.

When a user does undo check out to a file checked out by another user, the details are added in history.

Previously, only administrators could undo the check out or check in of files that are checked out by another user.

Quality Enhancements in SOLIDWORKS PDM

You can open the search results from the embedded Windows Explorer search tool in Microsoft Excel or export them as a comma-separated value (.csv) file. The **Open search result**  and **Export search result**  commands are available on the Search toolbar.

Click  to export the search results as a comma-separated value (.csv) file. Click  to open the search results in a Microsoft Excel spreadsheet.

You can copy links of files and paste them to notification messages to your colleagues. Right-click a file, select **Copy Link**, and paste the link in the new message. When you click the link, SOLIDWORKS PDM navigates you to the appropriate file in the vault.

In the Administrative Export File dialog box, you can expand or collapse specific nodes or all nodes. To expand or close all nodes, right-click a node or in the dialog box and select **Expand All Nodes** or **Close All Nodes**. When you remove the specific setting or variable, the expanded or collapsed structure is retained.

SOLIDWORKS PDM provides the `_SW_Last_Saved_With_` variable that provides mapping between the **Summary** block name and **Last Saved With** attribute name for `slddrw`, `sldasm`, and `sldprt` files. SOLIDWORKS PDM updates the value of the variable whenever you check in a file. In the Administration tool, in the Customizable Columns dialog box, you can select this variable to add a column in the file list or search result for specific users. You cannot delete this variable.

Revision Table Integration

SOLIDWORKS PDM can now read and write values from or to a SOLIDWORKS revision table. You can configure SOLIDWORKS PDM variables to automatically add information such as revision date, description, and approver to a new row in the table or to update the last row.

When you change the mapped variable values in the file's data card, the values in the latest row of the table are updated and vice versa.

The revision table row can be updated automatically by using:

- Set variable transition actions
- Set Revision command

Configuring Revision Table Integration

To configure revision table integration:

1. Configure the mapping between SOLIDWORKS PDM variables and revision table columns in the SOLIDWORKS drawing.

For details, see *SOLIDWORKS PDM Administration Guide: Mapping Variables to File Properties*.

2. Configure the **Revision Table** node.
3. Set a variable that holds the custom property revision.

You must set the Revision variable for the current state of a file during the set revision action and for the target state of a file during the change state action. For details, see *SOLIDWORKS PDM Administration Guide: Set Variables Dialog Box*.

4. Define the Set Variable transition actions for each variable.

You need not define the Set Variable transition action for the Zone variable as it is read-only.

Configuring the Revision Table Node

You must configure the Revision Table node to update the revision table rows.

To configure the revision table node:

1. In the Administration tool, expand **SOLIDWORKS** and double-click **Revision Table**.
2. Select **Enable Revision Table** to manage the revision table by SOLIDWORKS PDM.
3. Set the values on the **Revision Table Settings** and **Set Revision Command Settings** tabs.
4. Click **OK**.

Configuring the Revision Table Settings

You can set options on the Revision Table Settings tab.

To configure the Revision Table Settings:

1. Open the Revision Table dialog box.
2. On the Revision Table Settings tab, set the number of visible rows in the revision table.
3. In the **Revision placeholder character**, enter a placeholder character or characters.

Configuring the Set Revision Command Settings

You can set options on the Set Revision Command Settings tab to update the revision table when you use the Set Revision command.

In the File Explorer, in the Set Revision dialog box, you must select **Update Variable** to update the revision table.

To configure the Set Revision Command Settings:

1. Open the Revision Table dialog box and select the Set Revision Command Settings tab.
2. Select **Update Revision Table in SOLIDWORKS Drawing through "Set Revision" Command**.
3. Select a check box under the **Revision Table Column** for a variable to appear in the revision table.
4. Enter a value under **Column Value**.

You can click  to select the system variable.

5. Select a corresponding variable under **Variable Name**.
6. Click **OK**.

Defining Variable Mapping

You can configure the mapping between SOLIDWORKS PDM variables and revision table columns in SOLIDWORKS drawings.

To configure the variable mapping:

1. Expand the **Variables** node and edit the variables.
You can edit the current variables, **Approved by**, **Description**, **Date**, **Revision**, or create new variables. You must create the **Zone** variable as read-only because the value of this variable is read from the drawing.
2. In **Variable name**, type a name.
3. Set the **Variable type** as **Text**.
4. In **Block name**, type **SWRevTable**.
5. In **Attribute name**, select the attribute name.
For a custom column, you must type the attribute name that is the same as the revision table column header.
When you use the SWRevTable block for the default revision table column, you can select the attribute name from the list.
6. Type the file extension, `slddrw`, and click **OK**.

Revision Table Dialog Box

To open the Revision Table dialog box:

- Expand the **SOLIDWORKS** node and double-click **Revision Table**.

Enable Revision Table Select this option to manage the SOLIDWORKS drawing revision table using SOLIDWORKS PDM.
When revision tables are enabled in SOLIDWORKS PDM, the SOLIDWORKS **Alpha/numerical control** options are not available for Revision Table in **Tools > Options > Document Properties > Tables > Revision**. A message, **Revision driven from SOLIDWORKS PDM** appears in the SOLIDWORKS Tables Options dialog box.

Revision Table Settings

Number of visible rows

Sets the number of rows to display in the drawing revision table.
When the number of revision table rows in a drawing exceeds the set number, the oldest row is deleted.

Revision placeholder character(s)

Lets you enter characters that appear in the revision column of the revision table. The actual revision value replaces these characters when you change the revision in SOLIDWORKS PDM.

It is mandatory to enter one or more placeholder characters. The placeholder characters must be between 1 and 5 characters in length.

Set Revision Command Settings

Update Revision Table in SOLIDWORKS Drawing through "Set Revision" Command

Updates the revision table when you:

- Define the Set Revision action.
- Select **Update Variable** in the File Explorer in the Set Revision dialog box.

Select a check box to display a variable as a revision table column in the revision table.

Revision table column	Column value	Variable Name
Revision	By default, set to revision value set with Set Revision action.	Select the mapped variable, Revision . The list displays the variables that are mapped using the SWRevTable block name.
Description, Date, Approver	Click  to select a variable to be added to the column. You can also type the text.	Select the variable.

Setting Dynamic Variable Values in Copy Tree

With the enhanced Copy Tree variable settings, it is possible to update variables with dynamic values. You can set dynamic variable values in the Settings dialog box - Copy Tree page.

Previously, you could only use static values.

To set dynamic variable values in Copy Tree:

1. In the Administration tool, in the Settings dialog box - Copy Tree page, under **File types**, click **Add**.

2. Click **Add Variable** and select predefined variables from the list.
3. For **Value**, click  to select a dynamic value.

The following dynamic values are available:

- **Current time**
- **File Name**
- **File name without extension**
- **File Path**
- **Logged in user**
- **Target File Name**
- **Target File name without extension**
- **Target File Path**
- **Today's date**
- **User - Full name**
- **User - initials**
- **User - User data**

SOLIDWORKS PDM Application Programming Interface

See *SOLIDWORKS API Help: Release Notes* for late-breaking updates.

SOLIDWORKS PDM 2018 API includes the ability to:

- Add a custom tab to PDM vault views:
 - Customers and third-party users can add custom tabs to PDM vault views in Windows Explorer using a PDM API add-in.
 - API hooks to third-party development code can display special items in these custom tabs.
 - Add-ins can implement custom tabs with custom names and icons.
 - Add-ins can add any number of custom tabs to the vault view in Windows Explorer.
 - Add-ins can programmatically remove custom tabs.
- Programmatically refresh a data card when its card variables change.
- Restore deleted files from the Recycle Bin.
- Select the transition to use when changing a file's state.
- Specify whether to batch update only the variables that are part of the file data card.
- Get a list of values associated with a drop-down control on a data card.
- Provide more IEdmSearch comparators.

SOLIDWORKS PDM Support for Non-SOLIDWORKS CAD File References

SOLIDWORKS PDM supports the handling of references between SOLIDWORKS files and non-SOLIDWORKS CAD data created through 3D Interconnect.

You must add the non-SOLIDWORKS CAD files to the vault at the beginning so that they are referred from the file vault.

SOLIDWORKS PDM recognizes the non-SOLIDWORKS CAD references during check in of the parent SOLIDWORKS part or assembly and lists them as CAD references after check in is complete. You do not have to create any user-defined references. The CAD references are listed in the Contains tab, Bill of Materials tab, Where Used tab, and in any operation that lists the reference tree. This is true for both the parent SOLIDWORKS file and any parent non-SOLIDWORKS file.

For example, when you check in a SOLIDWORKS assembly along with an Inventor sub-assembly that is inserted in it, SOLIDWORKS PDM establishes PDM references between parent and its first level of child references. This also includes references between Inventor subassembly and its parts.

SOLIDWORKS PDM supports the following file formats through 3D Interconnect:

File format	Extension
Autodesk® Inventor	IPT, IAM
CATIA® V5	CATPART, CATPRODUCT
PTC®/CREO	PRT, PRT., XPR, ASM, ASM., XAS
Siemens™ NX	PRT
SOLID Edge®	PAR, PSM, ASM

This integration does not affect the behavior of a non-SOLIDWORKS CAD file in its native application, that is when working with the file outside 3D Interconnect.

24

SOLIDWORKS Plastics

This chapter includes the following topics:

- **Clamp Force in Machine Opening Direction**
- **Density Result at End of PACK Analysis**
- **Exclude Area from Clamp Force Calculation**
- **Export Deformed Geometry**
- **Mesh Enhancements**
- **Shrinkage Percentage in Warp Measure**
- **Temperature Criteria for Short Shots**

SOLIDWORKS Plastics Standard, SOLIDWORKS Plastics Professional, and SOLIDWORKS Plastics Premium are available as separately purchased products that can be used with SOLIDWORKS Standard, SOLIDWORKS Professional, and SOLIDWORKS Premium.

Clamp Force in Machine Opening Direction

You can specify the Injection Molding Machine Opening direction to estimate the clamp force in the selected direction.

In the Clamp Force PropertyManager, select one of the default axes (X, Y, or Z), or select a plane, planar face, or linear edge of your model to define a machine direction that is not aligned with a default axis.

To view the clamp force results:

- Create an X-Y plot.
- Access the **Flow and Pack** Summary where the clamp force in the user-defined machine direction is listed.

Density Result at End of PACK Analysis

You can view density results at the end of a PACK analysis for solid meshes.

Use the **Density at End of Pack** simulation result as a guideline to evaluate the effectiveness of your packing stage. The density should be relatively uniform across the part geometry. Large variations in density can lead to non-uniform shrinkage and warpage. Voids might form at areas with low density.

Exclude Area from Clamp Force Calculation

If your model contains undercuts or slides, you can exclude these areas from the clamp force estimation.

In the Clamp Force PropertyManager, click **Exclude Area** and select the elements of your model that represent the undercut or slide regions.

When you run the **FLOW** or **PACK** simulation, these elements are excluded from the clamp force calculation, for example the red areas that represent undercuts in the image.

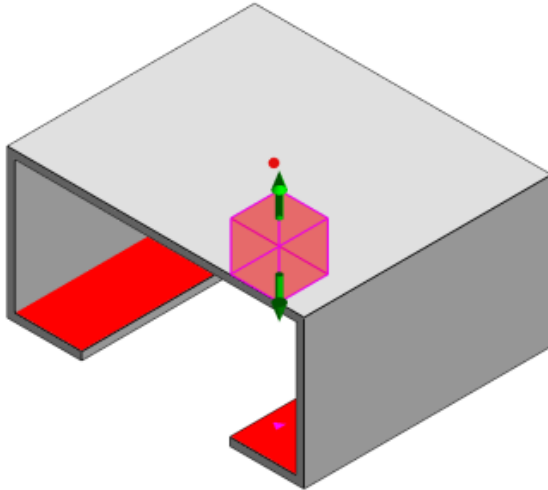

Export Deformed Geometry

An enhancement to the Export Deformed Geometry feature allows you to choose a non-uniform deformation scaling factor for each of the three major axes.

With the new export deformed geometry feature, you can export warped mesh models in Abaqus, STL, Nastran, and native SOLIDWORKS Plastics formats.

If you use the Automatic option to create the mesh, this feature is unavailable with solid meshes.

Mesh Enhancements

Several mesh enhancements improve the mesh creation process.

- Application of previously defined mesh settings when creating a new surface mesh, and ability to re-mesh the part in one step.
- Creation of Mesh groups enables an easier identification of dependent domains (cavity, runner, inserts) and independent domains (mold, cooling channels) during surface meshing. For all parts inside a dependent domain, the mesh is compatible in areas where the parts come into contact.
- Identification of SOLIDWORKS CAD geometry as a mold domain.

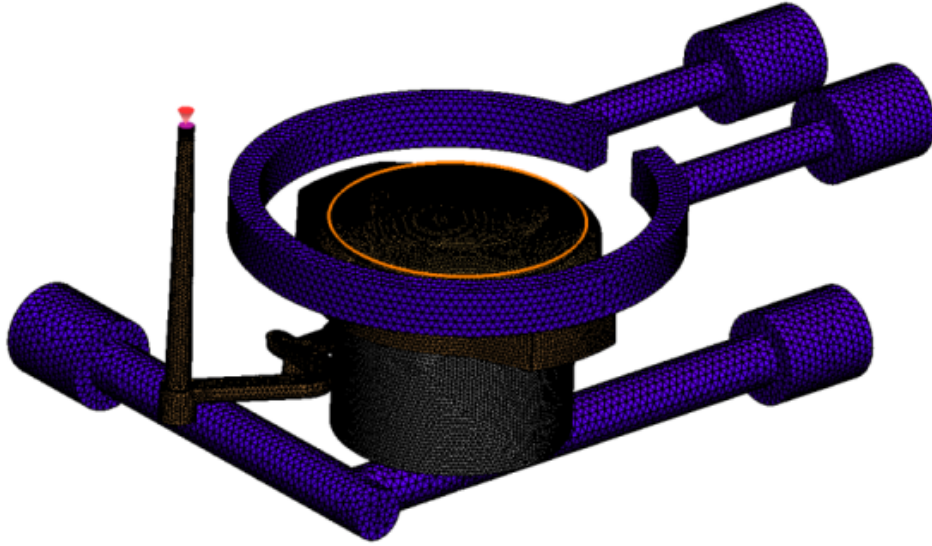

Shrinkage Percentage in Warp Measure

The Warp measure tool now displays the shrinkage amount (the distance between two reference nodes) both in terms of the absolute value (dR) and percentage value (dR[%]).

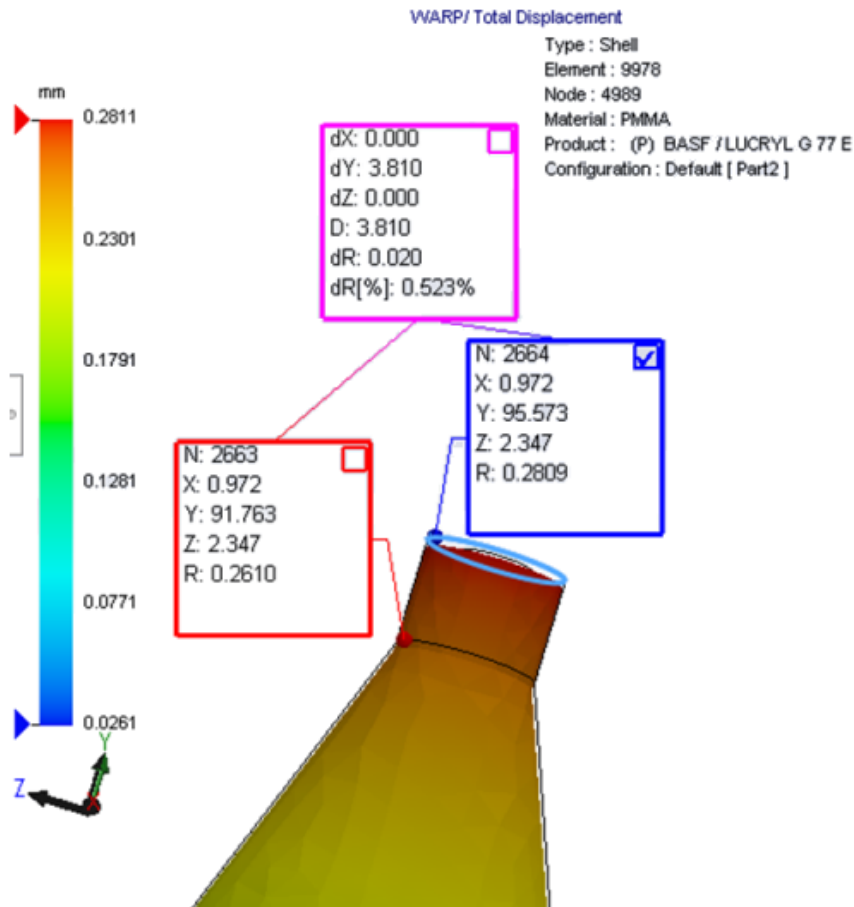

Temperature Criteria for Short Shots

A Flow Analysis setting **Temperature Criteria for Short Shots** improves the **FLOW** simulation accuracy of predicting potential short shots.

Short shots may occur when the temperature at the melt-front falls below the Glass Transition temperature of the plastic material.

The **Temperature Criteria for Short Shots** setting with the default temperature value set to the Glass Transition temperature is enabled by default. When this setting is enabled, the temperature within the elements along the melt front is continuously monitored, and when the temperature falls below the specified value, a short shot is detected.

25

Routing

This chapter includes the following topics:

- **Flattening Enhancements**
- **General Routing Enhancements**
- **Routing Library Manager Enhancements**

Routing is available in SOLIDWORKS Premium.

Flattening Enhancements

Highlighting Route Segments of Selected Connectors

In the flattened state, you can view the connected routes and components of selected route segments as highlighted routes in the graphics area.

When you right-click these entities, the shortcut menu options available are:

- Connectors: **View Connected Segments.**
- Route segments: **View Connected Connectors.**

Flattening Support for Clips with Multiple Route Segments

In the flattened state, where multiple, disjointed routes are present, clips are visually associated with at least one route segment and placed parallel to the route segment.

Repositioning Disjointed Routes

You can manually drag route assemblies in the flattened state. Select **Move Connected Route Segments** from the shortcut menu.

Connector table enhancements:

- You can view the following new options in the connector tables:
 - **Connected to Reference**
 - **Connected to Pin**
- You can add new columns in the connector table from a central location.

General Routing Enhancements

Piping: Grouping of Spool Components in BOMs

You can view spools in the **Bill of Materials** as separate entries. In the Bill of Materials PropertyManager, click **Routing Component Grouping > Group spool components**.

Electrical: Adding Splices to Routes

You can add splice components to routes with the **Add to Route** command. You can add splices in the graphics area and connect existing routes to it.

Routing Library Manager Enhancements

General Routing Library Manager Enhancements

Routing Library Manager Support for Non-English Languages

The Routing Library Manager supports routing library components in all standard SOLIDWORKS languages. When you create routing library parts in one language and open them in the Routing Library Manager of other languages, the software recognizes the routing-specific features.

Component Library Wizard

The Component Library Wizard enhancements include:

- The **Component library** node of the Component Library Wizard is divided into two sections - **Connectors Library**, and **Interconnect and Accessories Library**.
- For the **Interconnect and Accessories Library**, you can specify the library path and the specifications in the **Terminal List**. You can also add new accessories to the library with the **Add New** option.
- For the **Connectors Library**, you can specify the library path and the specifications in the **Component List** and the **Pin List**.
- You can add new columns in the **Pin List**. Right-click an existing column and click **Insert Column Left** or **Insert Column Right** on the shortcut menu.

Covering Library Wizard

The Covering Library Wizard enhancements include:

- The **Covering library** node of the Covering Library Wizard is divided into two sections - **Piping, Tubing, and Ducting**, and **Electrical**.
- For **Piping, Tubing, and Ducting**, you can specify the library path and the specifications in the **Covering List** and the **Material List**.

- For **Electrical**, you can specify the library path and the specifications in the **Covering List**.

Enhancements for Cable Wire Library Wizard, Component Library Wizard, and Covering Library Wizard

You can use vertical scroll bars to scroll through any of the lists in these wizards.

You can click  after any of the library paths, to browse to a file for viewing and editing it.

SOLIDWORKS Electrical and Routing User Interface Integration

You can access the Routing Library Manager from the SOLIDWORKS Electrical 3D tab. You can create CPoints and define mate references for electrical components from the

Routing Library Manager  instead of the **Electrical Component Wizard**.

To access the Routing Library Manager from the SOLIDWORKS Electrical 3D CommandManager, click **SOLIDWORKS Electrical 3D** and click Routing Library Manager.

The SOLIDWORKS Electrical 3D enhancements on the Routing Component Wizard tab of the Routing Library Manager include:

- Three new options in **Routing Functionality Points** under **Point Type**:
 - **Cpoint with circuit information**
 - **Cpoint from manufacturer part**
 - **Cable Cpoint**
- Three new options in **Mate Reference** under **Reference name**:
 - **For Rail**
 - **For Cabinet**
 - **For Cabinet Door**
- A new command in **Mate Reference** under **Component Alignment Options:Status, Define Faces**.

26

Sheet Metal

This chapter includes the following topics:

- **Creating Normal Cuts**
- **Tab and Slot**
- **Three Bend Corner Reliefs**

Creating Normal Cuts

With the **Normal Cut** tool, you can normalize all non-normal side walls in sheet metal models.

The **Normal Cut** tool applies a normal cut feature that is independent from the tools that removed the material. You can select several faces to define a normal sheet metal side wall (not top or bottom faces).



Although you can create extruded cuts with the **Normal Cut** option, this option is limited to individual extruded cut features.

To create a normal cut:

1. Open `system_dir:\Users\Public\Public Documents\SOLIDWORKS\SOLIDWORKS 2018\samples\whatsnew\sheet metal\normal_cut.sldprt`.

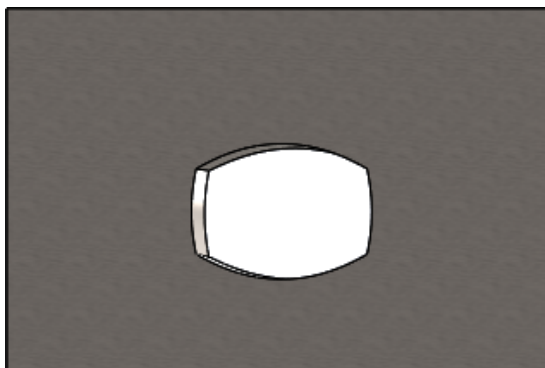
The part has lofted cuts with non-normal side walls.



2. Click **Normal Cut**  (Sheet Metal toolbar) or **Insert** > **Sheet Metal** > **Normal Cut**.
3. In the PropertyManager, under **Faces For Normal Cut** , select **Auto Propagation**.

4. In the graphics area, select the face of the cut.

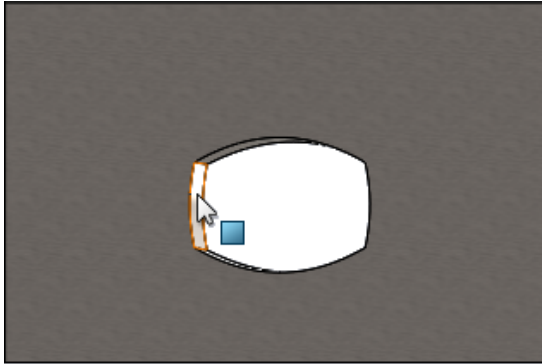

The software selects all faces of the cut.

5. In the PropertyManager, under **Normal Cut Parameters**, select **Extent**.
With **Extent**, the maximum amount of geometry is cut based on the outline at the top and bottom face.
6. Click .

The faces of the cut are normal to the top and bottom faces of the part.

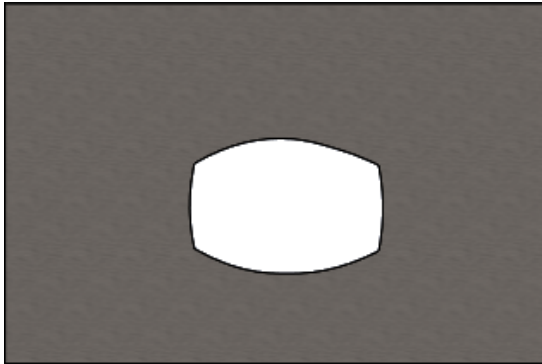

Tab and Slot

The **Tab and Slot** feature creates tabs on one body and slots (holes) on another body to interlock the two bodies. You can specify how the tabs and slots look and how they are distributed along the selected entities.

Tabs and slots make it easier to weld parts together and minimize the requirement to build complicated fixtures because you can interlock several sheet metal parts. This feature is available in all parts, not just sheet metal parts. You can use it in single bodies, multibodies, and parts in the context of an assembly.

Edges and faces must correspond to each other - when you select an edge for the tabs, you must select a matching face for the slots. The edges must be linear, the faces can be planar or cylindrical, but the edges and faces do not have to touch.

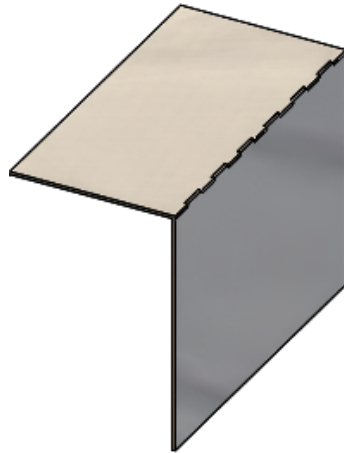



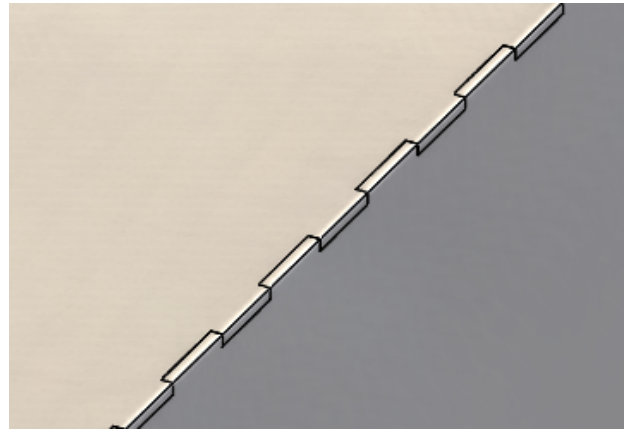

Tab and Slot feature



Enlarged image

Creating a Tab and Slot

To create a tab and slot:

1. Open `system_dir:\Users\Public\Public Documents\SOLIDWORKS\SOLIDWORKS 2018\samples\whatsnew\sheet metal\tab_and_slot.sldprt`.
2. Click **Tab and Slot**  (Sheet Metal toolbar) or **Insert** > **Sheet Metal** > **Tab and Slot**.
3. In the PropertyManager:
 - a) Under **Spacing**, select **Equal Spacing** and set **Number of Instances**  to 7.
 - b) Under **Tabs**, set **Length**  to 5mm, **Height**  to **Blind** and **Tab Height Value** to 5mm.

4. In the graphics area:

a) Select the edge shown for the **Tab Edge** .

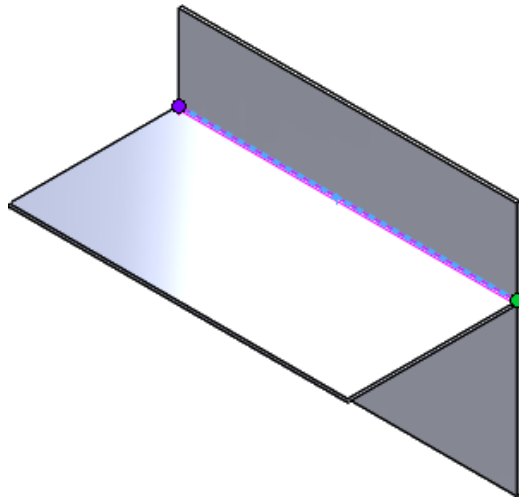

b) Select the back face shown for the **Slot Face** .

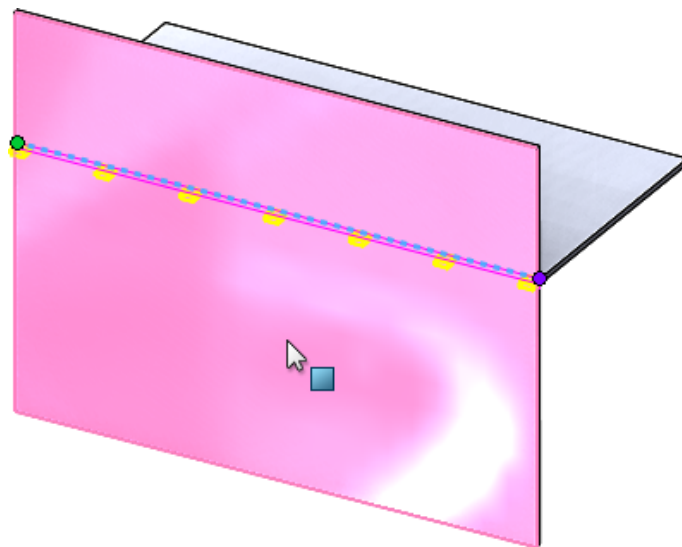

5. Click .

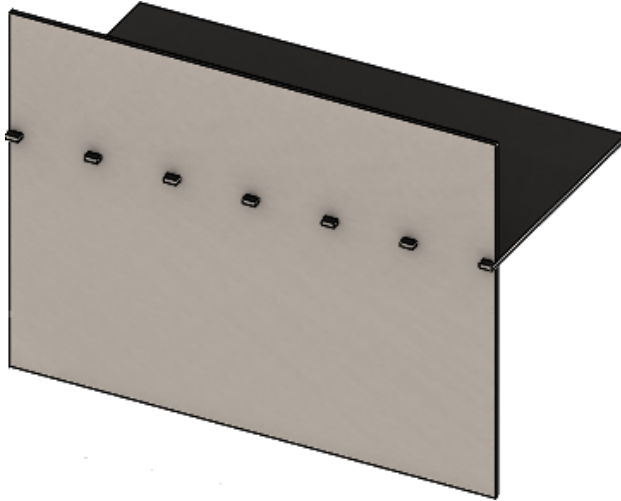

Three Bend Corner Reliefs

Improvements to three bend corner reliefs include:

- If a corner relief is smaller than the required corner cutout, it is now visible in the folded state.
- The ability to create a suitcase corner - a closed spherical corner without any cutouts.

Corner Relief Display

Three bend corners are improved to create corner reliefs that are smaller than the required default corner treatment when in the folded state.

Previously, the software could only create three bend corner reliefs in the folded part when the corner treatment was bigger than the necessary cutout that was required to unfold the part.

The following shows a circular corner relief in the folded state.

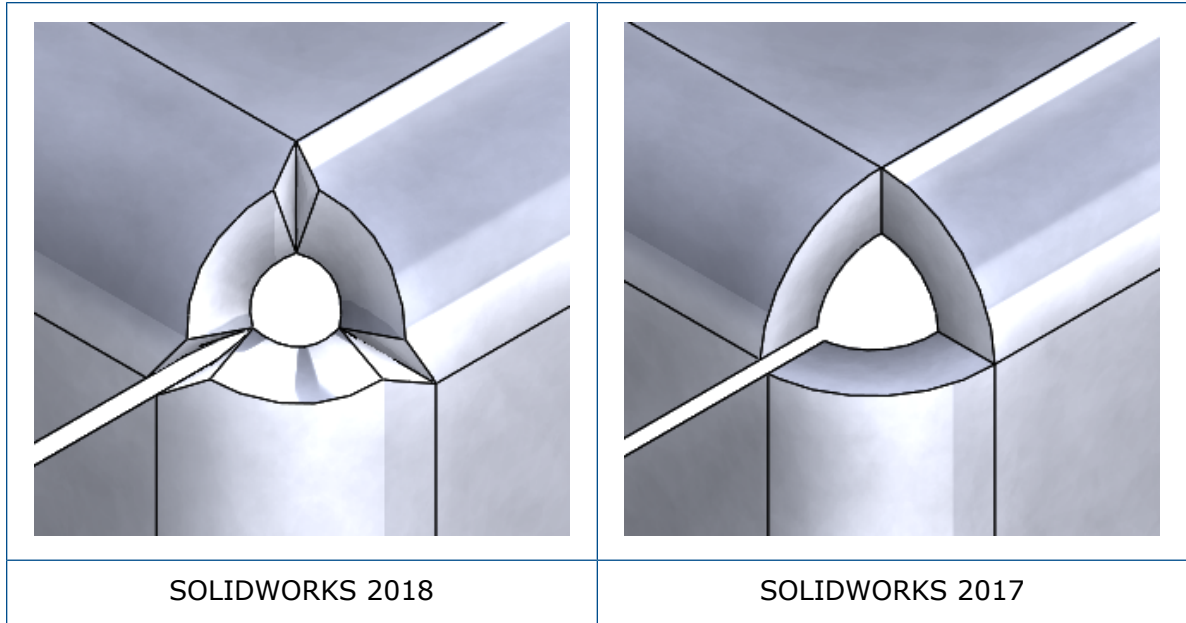

Creating Suitcase Corner Reliefs

A suitcase corner relief is a closed spherical corner without any cutouts. The sphere is based on the existing sheet metal parameters.

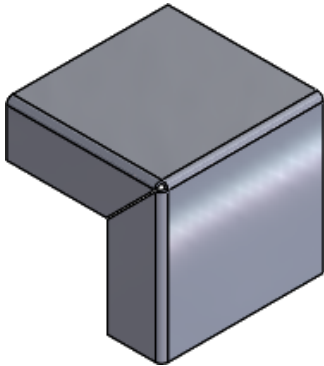

To create a suitcase corner relief:

1. Open `system_dir:\Users\Public\Public Documents\SOLIDWORKS\SOLIDWORKS 2018\samples\whatsnew\sheet metal\bracket.sldprt`.



2. Click **Corner Relief**  or **Insert > Sheet Metal > Corner Relief**.

3. In the PropertyManager, under:
 - a) **Corner Type**, select **3 Bend Corner**.
 - b) **Corners**, click **Collect all corners**.
 - c) **Relief Options**, select **Suitcase** and set the gap to one of the following:

Option	Description
Default Suitcase 	Leaves the gap unchanged.
Extend the gap into the bend area 	Cuts the corner relief with the gap.
Fill in some gap 	Extends the corner relief material into the gap.

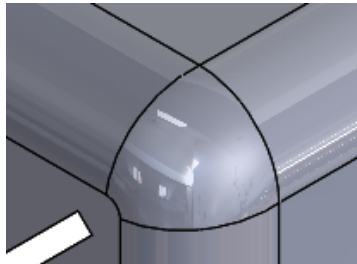
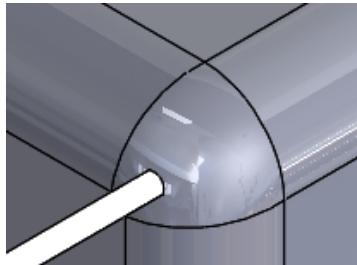
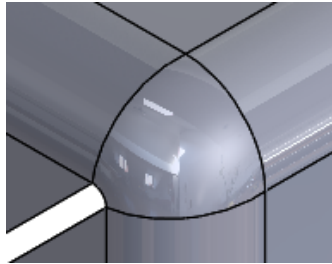

4. Click .

27

SOLIDWORKS Simulation

This chapter includes the following topics:

- **Topology Study**
- **Allow for Dismissal of Warning Messages**
- **Create a Results Plot from Imported Data**
- **Displacement Control for Nonlinear Contact**
- **Email Notification for Completed Analyses**
- **Factor of Safety Plot for Nonlinear Static Studies**
- **Import Simulation Study Features into Assemblies**
- **Improved Pin Connector**
- **Mesh Refinement for Stress Singularities**
- **Sensor for Simulation Mass Properties**

SOLIDWORKS Simulation Standard, SOLIDWORKS Simulation Professional, and SOLIDWORKS Simulation Premium are available as separately purchased products that can be used with SOLIDWORKS Standard, SOLIDWORKS Professional, and SOLIDWORKS Premium.

Topology Study

Use a Topology study to explore design iterations of a component that satisfy a given optimization goal and geometric constraints.

Available in SOLIDWORKS Simulation Professional and SOLIDWORKS Simulation Premium.

A Topology study performs nonparametric topology optimization of parts. Starting with a maximum design space (which represents the maximum allowed size for a component) and considering all applied loads, fixtures, and manufacturing constraints, the topology optimization seeks a new material layout, within the boundaries of the maximum allowed geometry, by redistributing the material. The optimized component satisfies all the required mechanical and manufacturing requirements.

For example, you can optimize the part of a car hood opening mechanism, as shown in the image below in blue, in terms of strength and weight (image courtesy of Ring Brothers LLC).

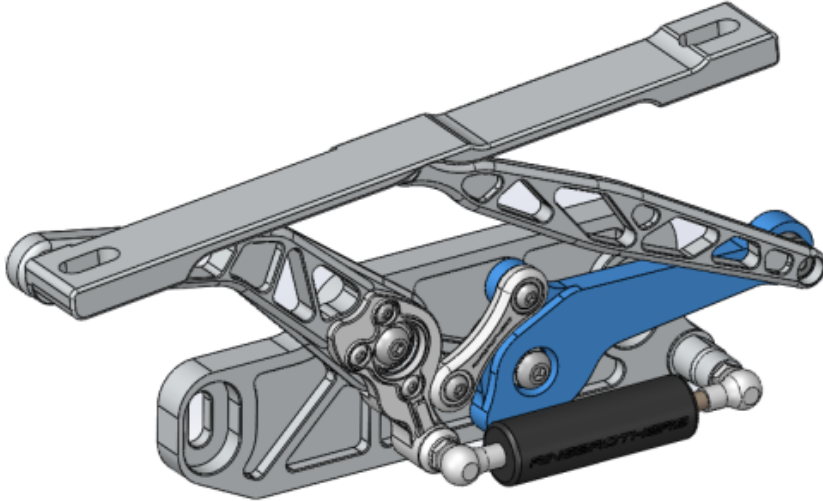

With a Topology study, you can set a design goal to find the best stiffness to weight ratio, minimize the mass, or reduce the maximum displacement of a component.

It is recommended to start with the **Best Stiffness to Weight ratio** goal to get an initial optimized shape of your component.

In addition to the optimization goal, you define design constraints to ensure that the required mechanical properties, such as maximum deflection, percentage of mass removed, and also manufacturing processes are satisfied. For a successful Topology study run, the design proposal reached by the iterative optimization process should fulfill all structural and manufacturing requirements entered.

In the **Study** PropertyManager, select **Topology Study**.

To set up a Topology study, you define:

One Goal The optimization goal drives the mathematical formulation of the optimization algorithm. In a Topology Study tree, right-click **Goals and Constraints**. In the Goals and Constraints PropertyManager, select one of the optimization objectives: **Best Stiffness to Weight Ratio**, **Minimize Mass**, or **Minimize Maximum Displacement**.

When you select **Best Stiffness to Weight Ratio**, the algorithm seeks to minimize the global compliance of the model which is a measure of the overall flexibility (reciprocal of stiffness). Compliance is defined by the sum of strain energies of all elements.

Constraints Constraints limit the design space solutions. They enforce limits to: percentage of mass to be removed, performance targets for the stresses (FOS), displacements, or eigenfrequencies observed in your model. You define optimization constraints in the Goals and Constraints PropertyManager. The user interface filters the type of constraints you can apply based on the goal you select.

Preserved Regions These are regions of your model that are excluded from the optimization process and are preserved in the final shape. The geometric entities where you apply loads and fixtures are preserved by default. To select the regions to exclude from optimization, go to **Topology > Options > Preserved (Frozen) Region settings**. To select additional faces to

preserve, right-click **Manufacturing Control**, and select **Add Preserved Region**.

Manufacturing Controls Geometric constraints enforced by manufacturing processes ensure that the optimized part is manufacturable. Right-click **Manufacturing Control**, and define the desired controls like **De-mold Direction**, **Thickness Control**, or **Symmetry Control**. In the De-mold Direction PropertyManager, you can also apply a stamping constraint to create holes across the thickness of a part. With the **Symmetry Control**, you can enforce half, quarter, or one-eighth symmetry to the optimized shape of the component.

Depending on the settings of the optimization goal, manufacturing controls, mesh, loads, and boundary conditions, the optimization process yields an acceptable design that is a derivative of the initial maximum design space.

Material Mass Plot

When the iterative optimization process completes, you view the optimized geometry of the component in a **Material Mass** contour plot.

During a Topology Optimization, the program starts with the given maximum physical space of a component, which includes all elements, and through an iterative process determines a new material distribution by removing the "soft" elements that do not contribute to the stiffness of the component for the particular load scenario, boundary conditions, and manufacturing controls.

For each element, the optimization algorithm couples the material's Young's modulus with a relative mass density factor ranging from 0.0001 (for a void element without any load-carrying capacity) to 1.0 (for a solid element with load-carrying capacity).

Elements with low relative mass densities (less than 0.3) are considered "soft" elements. These elements do not contribute to the overall stiffness of the component, and they can be safely removed. Elements with high relative mass densities (larger than 0.7), are considered "solid". These elements contribute the most to the overall stiffness (as a measure of the load-carrying capacity) of the component, and they should remain intact in the final design. The "solid" elements distribute the applied loads more effectively than the "soft" elements. An isovalue slider adjusts the inclusion of elements in the **Material Mass** plot according to their relative mass density values. The default position of the isovalue slider removes the elements with relative mass density values less than 0.3. Moving the slider to **Heavy** includes all elements, whereas moving the slider to **Light** plots only the solid elements, which cannot be removed.

A **Material Mass** plot of the optimized car hood component is shown below. The "soft" elements are removed from the optimized geometry (image courtesy of Ring Brothers LLC).

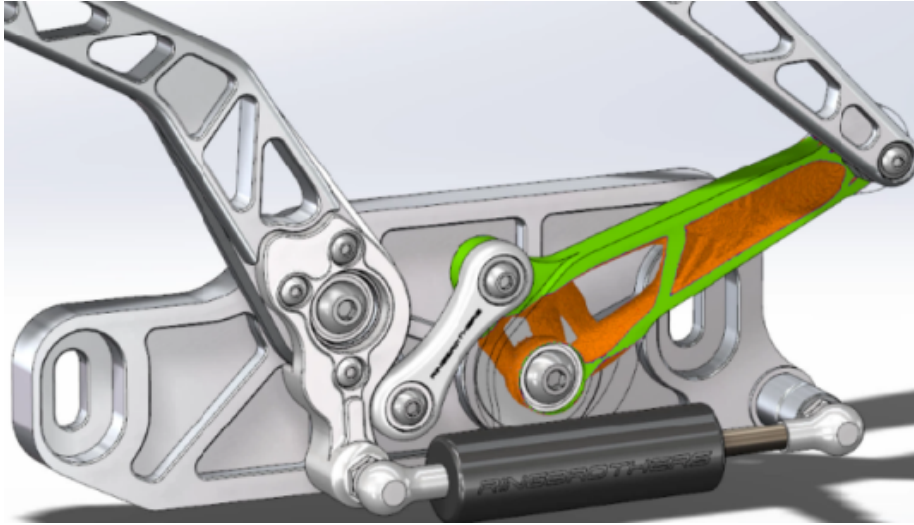

In the Material Mass PropertyManager, option **Calculate Smoothed Mesh** creates a smooth mesh from the active **Material Mass** plot. A smoothed mesh plot of the optimized car hood component is shown below (image courtesy of Ring Brothers LLC).

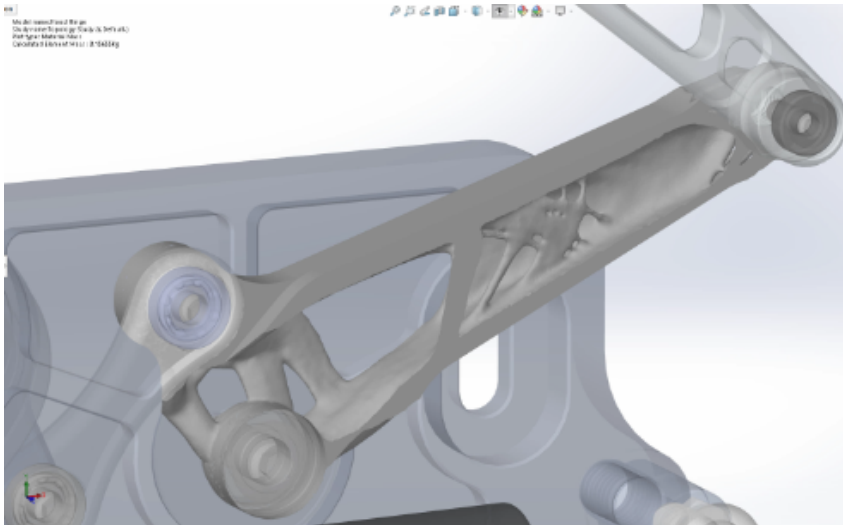

To save the smoothed mesh of the optimized part as new geometry, right-click the **Material Mass** plot, and click **Export Smoothed Mesh**. You can save the mesh data in a new configuration, or in a new part file.

Topology Optimization of a Plate

In this tutorial, you set up a Topology study with the goal to find the best strength to weight ratio of a plate while reducing its mass by 50%.

You create a Topology study to examine optimized shapes of a steel plate fixed on one side and loaded with a 750 N load.

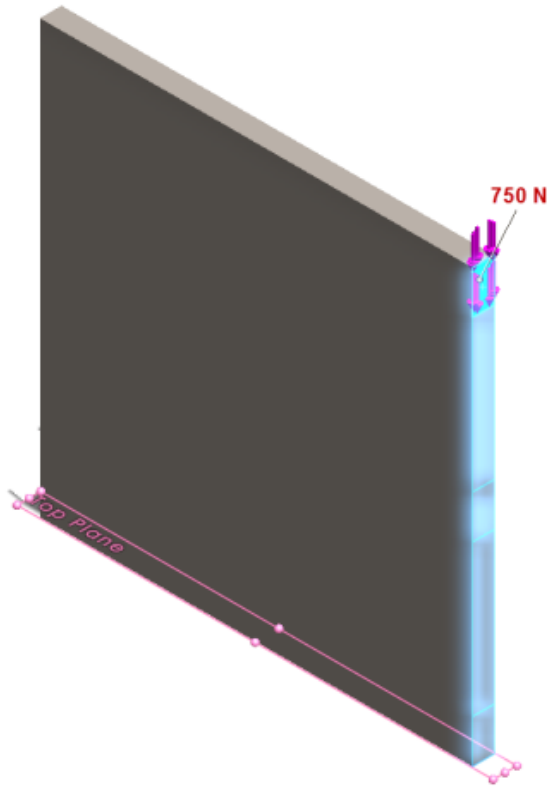

Opening the Part

To open the part file (`plate.sldprt`), browse to the file location

```
system_dir:\Users\Public\Public Documents\SOLIDWORKS\SOLIDWORKS  
2018\samples\whatsnew\Simulation\plate.sldprt
```

The **TopLoad_Ready** study includes:

- A static study with solid mesh
- ASTM A36 Steel material applied to the part
- A fixed restraint on a face
- A load of 750 N

Creating a Topology Study

You create a Topology study with a goal to find the best strength to weight ratio of the plate, while reducing its mass by 50%.

1. Click **New Study** (Simulation CommandManager).
2. Under **Design Insight**, click **Topology Study** and click .
The **Topology Study 1** study tab is created.
3. Copy from the **TopLoad_Ready** static study the fixed restraint **Fixed-1** and the load **TopForce (:Per item: -750 N)** to the new topology study.

4. In the Topology study tree, right-click **Goals and Constraints**, and click **Best Stiffness to Weight ratio (default)**. In the Goals and Constraints PropertyManager:
 - a) Under **Constraint 1**, for **Reduce mass by (percentage)** set 50 (%) for **Constraint Value**.
 - b) Click .

The optimization algorithm will try to minimize the compliance of the model (reciprocal of stiffness) which is defined by the sum of strain energies of all elements.

Setting Study Properties and Running the Study

1. Right-click the top **Topology Study1** icon, and select **Properties**.
2. In the **Options** tab (Topology dialog box) do the following:
 - a) For **Solver**, select **Intel Direct Sparse**.
 - b) Select **Run Static analysis before running topology study**.
 - c) Under **Preserved (Frozen) Region settings**, select **Regions with loads and fixtures**. Three regions remain unchanged by optimization.
 - d) Click **OK**.
3. Click **Run This Study** (Simulation CommandManager).

The optimization algorithm through several iterations will try to reach convergence.

Viewing Results

1. Under **Results**, double-click **Material Mass 1(-Material Mass)**.

The Material Mass PropertyManager plots isovalues of the elements' relative mass densities. Elements with higher mass densities are considered solid, and they must remain in the "optimized" shape. Elements with lower mass densities are considered "soft" and can be removed. Move the slider under **Display** to the rightmost position **Light** to plot only elements with mass densities close to 1 (must keep). Move the slider to the leftmost position **Heavy** to plot all elements. The color chart option of the material mass plot is set to **Optimized for Material Mass**. Red and green colors are removed from the material mass plot color scale to better assist color-blind users when viewing the plot.

The default position of the slider plots all elements with relative mass densities larger than 0.3. The remaining mass of the plate (at the default slider position) measures 25.56 Kg which equals to 52% of the original mass of 49.06 kg.

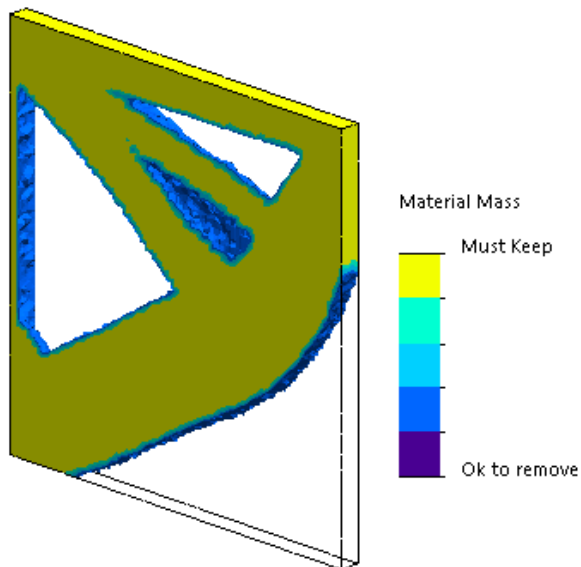

2. Click **Calculate Smoothed Mesh** .

The program creates smooth surfaces of the optimized shape so that the final design is ready to manufacture.

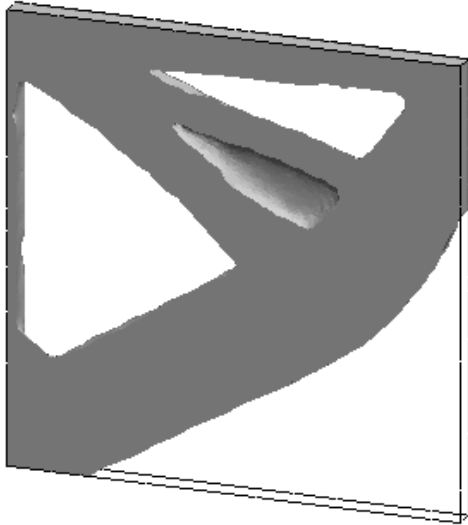

3. Click .

To save the smoothed mesh into a new configuration, or a new part, right-click **Material Mass1 (-Material Mass)**, and click **Export Smoothed Mesh**.

Allow for Dismissal of Warning Messages

You can suppress recurring warning messages that appear in a simulation workflow.

Select **Do not show me this again** in the message dialog to suppress the recurrence of the message. You can restore the suppressed messages from the Simulation **System** options dialog box.

Create a Results Plot from Imported Data

You can create simulation results plots by importing data from an external file.

Right-click the top study icon of a study tree, and click **Plot Imported Results**.

Select the input file to import the external results data. The input file can be either a text `*.txt` file, or a comma/space delimited `*.csv` file. Mapping of results is achieved per node or element number. The current mesh of the active study and the mesh from which the imported results are derived must be identical.

The data are stored in two columns. First column lists the node or element number, and second column lists the scalar values associated to the respective node or element.

Displacement Control for Nonlinear Contact

You can use the **Displacement Control** method to solve nonlinear contact analysis with the Direct Sparse and Intel Direct Sparse solvers only.

The **Displacement Control** method is enhanced to handle post buckling behavior in nonlinear analysis. Only the surface-to-surface contact formulation is supported when activating **Displacement Control**.

Email Notification for Completed Analyses

Automatic email notification when the analysis completes allows you to track the status of a running Simulation study.

Click **System Options > Email Notification Settings** to set up the email server settings. You can set up email notification delivery to track the solution status of a simulation study. You get email notifications for these cases:

- The solver completes the simulation. Select **Email when simulation is completed** in the Notification tab of the study properties dialog box.
- The solver encounters numerical difficulties and does not complete the simulation.
- Time-based notification about the solution status of a study, for example every 20 min, 40 min, etc. Select **Time based notification** in the Notification tab of the study properties dialog box.

Factor of Safety Plot for Nonlinear Static Studies



The factor of safety plot is extended to nonlinear static studies.

After a nonlinear static analysis completes, you can create a factor of safety plot based on a defined failure criterion.

Right-click **Results** and click **Define Factor of Safety Plot**. Create a factor of safety plot from results derived from a selected solution step or from the extreme values across all solutions steps.

Import Simulation Study Features into Assemblies



When creating a new static study, you can copy simulation features defined on a part or sub-assembly document into the new study created on an assembly document.

To import study features in an assembly document:

- Right-click the top study icon, in a static study PropertyManager, and select **Import Study Features**, or

- When creating a new static study, in the Study PropertyManager, select **Import Study Features**.

In the Import Study Features dialog box, you can select from the **Assembly Hierarchy** the parts and sub-assemblies associated to the study features you want to import.

The simulation features you can import are material, element types, contact, connectors, fixtures, loads, and mesh control definitions from static studies. You can import all simulation features or select which features to import.

You cannot import study features from 2D Simplification studies (plane stress, plain strain, and axisymmetric).

For models that have multiple instances of parts or sub-assemblies, you can propagate the selected study features to all instances in the assembly (or part) document. Click **Propagate imported study features to all instances (*)**.

Improved Pin Connector ★

You can define a pin connector through more than two cylindrical surfaces in one definition.

An improved user interface allows the definition of a single pin connector applied to multiple cylindrical faces (maximum ten). You select all coaxial cylindrical surfaces that are attached to the pin in a single selection box.

For example, for the two models shown below, you can define two pins (one for each model) to connect the two rotating parts and the six cylinders of a hinged plate.

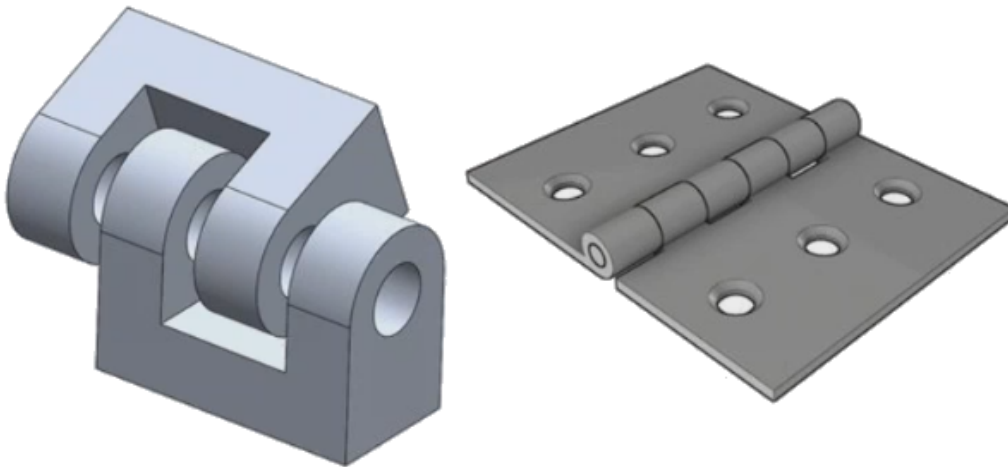

This improved pin connector definition is available for linear static, frequency, buckling, and linear dynamic studies.

Mesh Refinement for Stress Singularities

The Stress Hot Spot Diagnostics functionality is improved with the addition of Stress Singularity detection algorithm.

When the **Stress Hot Spot** diagnostics tool detects regions of the model that exhibit the highest stress gradients, you can apply local mesh controls to selected geometric edges, like sharp edges, in the hot spot regions. The improved algorithm with the addition of mesh refinement filters stress singularities from the stress hot spot regions.

The enhanced stress hot spot diagnostics tool allows you to:

- Select edges to apply mesh controls and change the mesh size.
- Refine the mesh locally up to three levels.
- View stress variations across different mesh levels on the selected edges to confirm the presence of stress singularities in your model.

Sensor for Simulation Mass Properties

You can monitor Simulation mass properties with a sensor.

To create a Simulation mass properties sensor:

In the Sensor PropertyManager, select **Simulation Data** for **Sensor Type**  and **Simulation Mass Properties** for **Results**.

The Simulation mass sensor tracks mass properties (mass, volume, surface area, and center of mass coordinates) for bodies, remote masses, and bolts.

You can use a Simulation mass properties sensor either as a Constraint or as a Goal in Design Studies.

28

Sketching

This chapter includes the following topics:

- **Controlling the Tangency Direction**
- **Creating Mirrored Entities in 3D Sketch**
- **Enabling and Disabling Automatic Solve and Undo for Sketches**
- **Fixing the Rotation of Sketch Pattern Instances**
- **Instance Limit Removed for Circular Sketch Patterns**
- **Mirroring Entities Using Reference Planes and Planar Faces**
- **Pen, Touch, and Gesture-based Sketching**
- **Smart Dimension on the Context Toolbar**

Controlling the Tangency Direction

You can flip the tangency direction of certain curved sketch entities. This includes arcs and splines.

To control the tangency direction:

1. Open `system_dir:\Users\Public\Public Documents\SOLIDWORKS\SOLIDWORKS 2018\samples\whatsnew\sketching\Block.sldprt`.
2. In the FeatureManager design tree, under **Cut-Extrude1**, right-click **Sketch3** and click **Edit Sketch** .

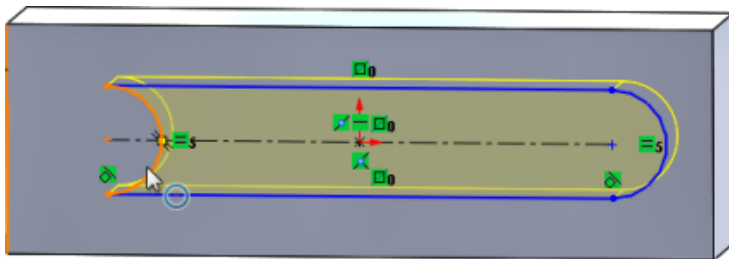

3. In the graphics area, right-click the arc and click **Reverse Endpoint Tangent** on the shortcut menu.

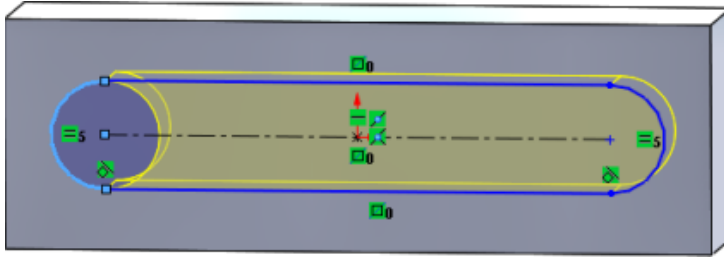

The software reverses the tangency and flips the arc.





4. Click **Edit > Rebuild**.



Creating Mirrored Entities in 3D Sketch

You can use the **Mirror Entities** tool in **3D Sketch**.

To create mirrored entities in 3D Sketch:

1. Click **3D Sketch**  (Sketch toolbar) or **Insert > 3D Sketch**.
2. Create sketch entities.
3. Click **Mirror Entities**  or **Tools > Sketch Tools > Mirror**.
4. Select sketch entities for **Entities to mirror**.
5. Select any plane or planar face for **Mirror about** .
6. Click .

Enabling and Disabling Automatic Solve and Undo for Sketches

You can enable and disable **Automatic Solve Mode** and **Undo**, and modify the threshold limit for sketch entities.

Previously, when you worked with large sketches, the **Automatic Solve Mode** and **Undo** would repeatedly turn off in large sketches.

Parts and Assemblies

To control Automatic Solve and Undo in Parts and Assemblies:

Click **Tools > Options > System Options > Sketch**.

- To disable the behavior of automatic turn off of **Automatic Solve** Mode and **Undo**, clear **Turn off Automatic Solve Mode and Undo when sketch contains more than this number of sketch entities**.
- To modify the threshold limit, select **Turn off Automatic Solve Mode and Undo when sketch contains more than this number of sketch entities** and enter the input value in the input box.

Click **OK**.

Drawings

To control Automatic Solve, Undo, and No Solve Move in Drawings:

Click **Tools > Options > System Options > Drawings > Performance**.

- To disable the behavior of automatic turn off of **Automatic Solve Mode** and **Undo**, clear **Turn off Automatic Solve Mode and Undo and turn on No Solve Move when drawing view contains more than this number of sketch entities**.
- To modify the threshold limit, select **Turn off Automatic Solve Mode and Undo and turn on No Solve Move when drawing view contains more than this number of sketch entities** and enter the input value in the input box.

Click **OK**.

The system options above are selected by default. If you clear the options, **Automatic Solve** and **Undo** tools remain enabled regardless of the number of sketch entities you create.

Fixing the Rotation of Sketch Pattern Instances

In the Linear Sketch Pattern PropertyManager, you can fix the rotation of sketch instances to **Direction 1** by selecting **Fix X-axis direction** under **Direction 1**. When you select this option, the pattern instances are fixed to **Direction 1**.

Instance Limit Removed for Circular Sketch Patterns

Circular sketch patterns are no longer limited to the number of instances allowed.

Mirroring Entities Using Reference Planes and Planar Faces

You can mirror entities about reference planes or planar model faces.

Previously, you could only mirror entities about linear entities such as lines or edges.

Click **Mirror**  (Sketch toolbar) or **Tools** > **Sketch Tools** > **Mirror** > **Mirror About** and select a reference plane or a planar face in the graphics area.

Pen, Touch, and Gesture-based Sketching

You can use pen and touch with compatible, touch-enabled devices to create free-hand sketch strokes and convert them into sketch geometry with the tools in the Sketch Ink CommandManager.

This functionality is available only on Windows 10 Creators Update.

To activate the Sketch Ink CommandManager, right-click the CommandManager tab and click **Sketch Ink** or **View** > **Toolbars** > **Sketch Ink**.

To access the **Touch**  tool, in the Sketch Ink CommandManager, click **Touch** and use a finger to sketch entities in the graphics area.

To access the **Pen**  tool, in the Sketch Ink CommandManager, click **Pen** and use a stylus or pen to sketch entities in the graphics area.

You can create:

- Lines
- Arcs
- Polygons
- Circles
- Ellipses

Smart Dimension on the Context Toolbar

You can dimension certain entities from the **Auto Insert Dimension** tool on the context toolbar.

Previously, you could only pre-select entities and then use the **Smart Dimension**  tool to dimension entities.

The **Smart Dimension**  tool on the context menu no longer supports pre-selection. If you want to add a dimension to your selection, use the **Auto Insert Dimension** on the context menu.



The **Auto Insert Dimension** tool automatically inserts the most appropriate dimensions for sketch entities.

The entities supported by the dimensioning tools on the context menu are:

- Line: Linear dimension
- Arc: Radial dimension
- Circle: Diameter dimension
- Two lines at an angle: Angular dimension between entities
- Two parallel lines: Linear dimension between entities
- Arc or circle, and line: Linear dimension between line and center point
- Point and line: Linear dimension between line and point
- Arc or circle, and point: Linear dimension between point and center point
- Arc/Arc or Circle/Circle or a combination thereof: Linear dimension between center points.

Controlling Dimensions with the Context Toolbar

To control dimensions with the context toolbar:

1. Create a sketch with two lines.
2. **Ctrl** + select two lines.
3. On the context toolbar, click **Make Parallel** .
4. **Ctrl** + select the two lines and select **Auto Insert Dimension** on the context toolbar.
5. In the **Modify** dialog box, type a dimension.
6. Click .

The dimension is applied to the entities.

29

SOLIDWORKS Toolbox

This chapter includes the following topics:

- **Descriptions and Comments No Longer Disappear**
- **Hexalobular Hardware**
- **Importing and Exporting Hole Wizard Data**
- **Selecting PEM Inserts**
- **Toolbox User Interface and Workflow**

SOLIDWORKS Toolbox is available in SOLIDWORKS Professional and SOLIDWORKS Premium.

Descriptions and Comments No Longer Disappear

For Toolbox components, if you add information in **Description** and **Comment**, the information is now preserved even if no **Part Number** is assigned.

Previously, the information was deleted if no **Part Number** was assigned.

In the Toolbox Configure Component PropertyManager, in the **Part Numbers** box, you are informed if a particular configuration has not been assigned a **Part Number** or a **Description** (if implemented). You can leave **Part Number** and **Description** unassigned, or add them through **Toolbox Settings** or by clicking **Edit** in the Toolbox Configure Component PropertyManager.

Hexalobular Hardware

Hexalobular (Torx) hardware is available in Toolbox.

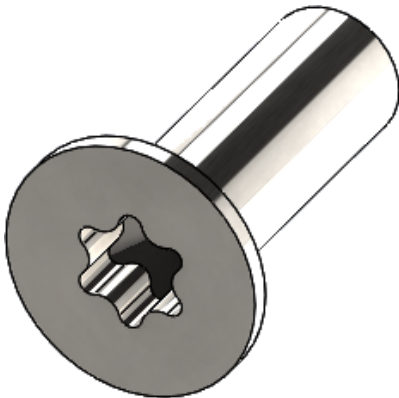

The following hardware has been added:

- ISO 14587 (2011) Hexalobular Socket Raised Countersunk (oval) Head Tapping Screws
- ISO 14581 (2013) Hexalobular Socket Countersunk Flat Head Screws
- ISO 14582 (2013) Hexalobular Socket Countersunk Head screws, High Head
- ISO 14584 (2011) Hexalobular Socket Raised Countersunk Head Screws



To access this hardware, click **Design Library**  > **Toolbox**  > **ISO** > **Bolts and Screws** > **Self Tapping Screws** or **Hexalobular Socket Head Screws**.

Importing and Exporting Hole Wizard Data

You can import and export data from Microsoft Excel files for Hole Wizard holes. This is helpful when you edit an entire standard or create several new sizes of holes.

To import and export hole wizard data:

1. Do one of the following:
 - In SOLIDWORKS, click **Tools** > **Options** > **System Options** > **Hole Wizard/Toolbox** > **Configure**.
 - From the Windows **Start** menu, click **All Programs** > **SOLIDWORKS version** > **SOLIDWORKS Tools** > **Toolbox Settings version** > **Configure**.
2. In the dialog box, click **1. Hole Wizard**.
3. Browse to the type of hole to import or export data for, such as **ISO** > **Straight Holes** > **Tap Drills**.
4. Under Standard Properties, click the arrow on the **Microsoft Excel**  button and click one of the following:

Option	Description
Import Hole Data Tables 	Imports hole table data into Toolbox. If there are errors in the data, an error report appears. After the import, you can: <ul style="list-style-type: none"> • Replace existing data tables. Removes all existing data from the current data tables and replaces it with data from the imported file. • Append new data to existing data tables. Adds the imported data to the end of the current data tables.
Export Hole Data Tables 	Saves the hole table data to a Microsoft Excel file.

Selecting PEM Inserts

The workflow for selecting PEM inserts is improved.

In the Hole Wizard and Advanced Hole PropertyManagers, when you select **PEM Inch** or **PEM Metric** for **Standard**, the **Filter** field now appears above the **Type** field. This better matches the workflow of filtering before selecting the type.

Toolbox User Interface and Workflow

Visual and functional improvements have been made to the Toolbox Settings user interface.

Improvements:

- Icons are updated to match those used in SOLIDWORKS, and are moved to consistent locations.
- Forms are updated to display more information in more consistent format.
- In various Toolbox component tables, some columns have been hidden. Previously, the columns (such as **Sort**, **OnFeatures**, and **OffFeatures**) were erroneously shown and were not meant to be user-editable.

30

SOLIDWORKS Utilities

This chapter includes the following topics:

- **SOLIDWORKS Design Checker Misaligned Mates**

SOLIDWORKS Design Checker Misaligned Mates

SOLIDWORKS Design Checker can detect the presence of misaligned concentric mates.

You can check for:

- Any misaligned mates
- Misaligned mates where the deviation exceeds a maximum deviation value
- Misaligned mates where the deviation exceeds a specified value

31

SOLIDWORKS Visualize

This chapter includes the following topics:

- **3DConnexion Spacemouse Support**
- **Area Light Enhancements**
- **Cloud Library Enhancements**
- **Decal Improvements**
- **Help Menu Improvements**
- **Import all SOLIDWORKS Cameras, Custom Views, and Lights**
- **Interactivity Performance Improvements**
- **Remove Camera Post-Processing from Backplates**
- **Stereoscopic and 360° Cameras for Virtual Reality**
- **Updated User Interface**

SOLIDWORKS Visualize is available as a separately purchased product that can be used with SOLIDWORKS Standard, SOLIDWORKS Professional, and SOLIDWORKS Premium or as a completely separate application.

3DConnexion Spacemouse Support

SOLIDWORKS Visualize 2018 supports all 3DConnexion® 3D motion controllers.

Navigation Modes

You can apply the controller motion information to three different navigation modes. To specify the **Navigation Mode**, click **Tools > Options > User Interface > Spacemouse Options**.

Navigation Mode - Object (Default)

Object mode navigation makes the user believe that he is holding the object in his hand. This mode is used in the modeling and inspection of parts and assemblies. This mode uses a smart algorithm to automatically set the rotation center of the camera. While the entire scene is visible in the viewport, the center of the scene is taken as the rotation center. When a user zooms close to objects to investigate details, the rotation center is set to a point on the 3D object's surface that is in the middle of the viewport. This mode is also most commonly used in the SOLIDWORKS software.

Navigation Mode - Camera

Camera mode gives the user the impression that he is moving around in the scene he is observing. A typical use for a camera mode is exploring virtual sceneries, similar to the navigation known from first

person games. This mode requires the user to move and turn in the direction that the cap on the 3D Mouse moves, and causes the objects displayed to move in the opposite direction to object mode described above. In camera mode, the center of rotation is at the eye or view point (actually the position of the camera itself).

Navigation Mode - Fly



Fly mode is used to describe navigation mode where the horizon is required to always remain leveled or horizontal. Fly mode is the same as camera mode with the additional horizontal constraint.

Object Manipulation

In addition to changing the view or camera, you can use the 3D motion controller to move and transform the selected 3D objects (Models, Groups and Parts). Press the **SHIFT** key while using the 3D motion controller.

The selection of 3D objects can not be empty.

These object manipulation modes in the Main toolbar are supported:

	Move	Translates or rotates objects according to the input from the 3D motion controller.
	Scale	Scales objects along the X, Y, and Z axes.
	Pivot	Translates the Pivot or rotation center of objects along the X, Y, and Z axes.

Virtual 3D Mouse Commands

SOLIDWORKS Visualize supports a set of commands that are predefined by 3DConnexion® to reset the view or choose commonly-used orthographic and isometric views. These commands are supported by a wide range of 3D applications and often have dedicated buttons on the motion controller devices.

Application Commands

SOLIDWORKS Visualize offers a wide range of application or action commands that you can customize and allocate to device buttons or virtual menus to speed up your most common workflows.

SOLIDWORKS Visualize includes more than 90 application commands that you can customize using the 3DConnexion® properties menu from the motion controller's device driver.

Area Light Enhancements

You can create light sources simulated as rectangles, discs, spheres, and cylinders.

These area light sources are extremely efficient in Fast mode. They can replace the emissive-plane technique for creating simulated light cards in scenes, which provide more reflections in your geometry and actual emissivity in Fast mode.

Additional improvements let you create and place lights on the fly. The lights are matched to the current camera's position and direction, or you can place them by clicking on the model where you want the lights to shine.

You can create new lights by selecting **Pick Target** or **Match Current Camera** from the **New Light** menu. For example, on the Scenes tab, click **Add** and choose **New Light**, **Pick Target**, or **Match Current Camera**.

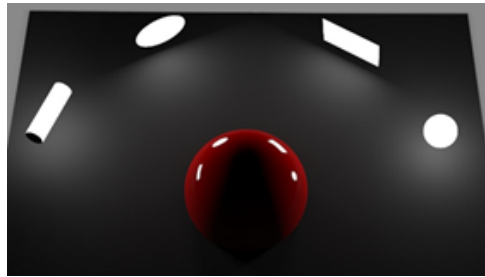

New area light types in Fast mode, from left to right: **Cylinder**, **Disc**, **Rectangle**, and **Sphere**

Cloud Library Enhancements

The Cloud Library performance improvements let you quickly select individual or multiple assets to download without interrupting your workflow.

- Hover over an asset's thumbnail of content that hasn't been downloaded for quick and easy downloading.
- Cancel a download at any time.
- Press **CTRL** and select multiple assets to download them all at once.
- This download is now a separate process, so you can continue using SOLIDWORKS Visualize while downloading assets.

Decal Improvements

SOLIDWORKS Visualize 2018 introduces an all new decal system, providing several key improvements and new functionality.

Support of all SOLIDWORKS Decal Types

Cylindrical Maps all points onto a cylinder

Spherical	Maps all points onto a sphere
Planar/Projection	Maps all points onto a specified plane and then projects the decal onto the reference entity
Label	Maps decals onto the model faces, including multiple contiguous nonplanar surfaces with no stretching or shrinking



SOLIDWORKS



SOLIDWORKS Visualize

Animation Keyframe Support

You can create unique decal animations by right-clicking a decal and clicking **Add Keyframe**. You can scale and position decals. In addition, you can animate the **Opacity** (visibility) to show items such as multiple decal options, slide shows, flashing billboards, and flickering TV screens.

Additional Key Improvements

- Floating decal issues, with noticeable drop shadow, are resolved
- Improved overall performance and files with many decals are handled properly
- No limit on the number of decals per project/part
- Support for up to 6 overlapping decals on a single part

Help Menu Improvements

The Help menu improves access to the help and documentation resources and aligns with other SOLIDWORKS products.

All documentation resources, including SOLIDWORKS Visualize Help, Tutorials, Release Notes, and What's New, are accessible from the Help menu. To guarantee the documents remain up-to-date and to minimize the required installation and installer size, the links reference online resources.

All SOLIDWORKS Visualize documentation is now available online only. An internet connection is required to access the documentation, however, you can then download the documents for future offline use.

The following actions to manage licenses are now accessible from the Help menu:

- Activate License (for Standalone licenses)
- Deactivate License (for Standalone licenses)
- SolidNetWork License Manager (for Network licenses)

Import all SOLIDWORKS Cameras, Custom Views, and Lights

When you import a SOLIDWORKS model into SOLIDWORKS Visualize, you can now import all custom defined SOLIDWORKS Cameras, custom saved views, and physical lights.

Cameras and Saved Views

When you import a SOLIDWORKS model and choose to import **Cameras**, all cameras and custom SOLIDWORKS views are imported into SOLIDWORKS Visualize. These import as SOLIDWORKS Visualize Cameras and are displayed in the Camera's tab in SOLIDWORKS Visualize. All aspects of SOLIDWORKS cameras and saved views are maintained and replicated in SOLIDWORKS Visualize.

To import cameras and saved views, the model must be saved in SOLIDWORKS 2018.

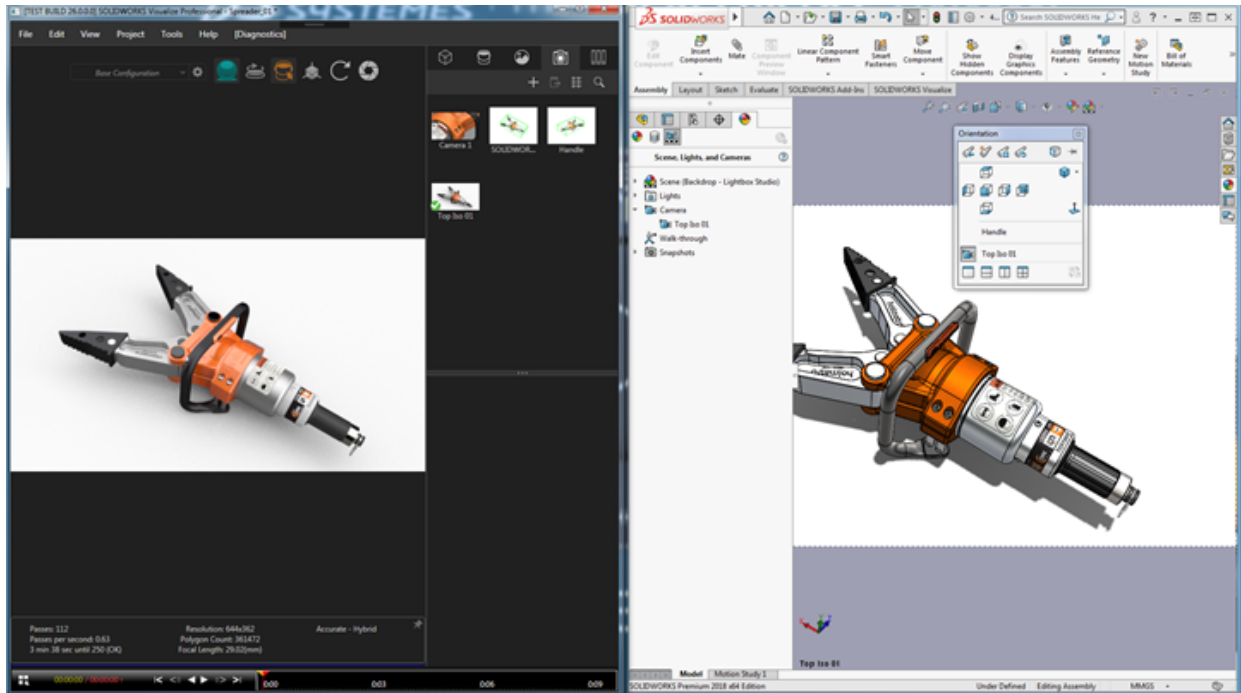

Physical Lights

When you import a SOLIDWORKS model and choose to import **Lights**, all directional, point, and spot lights saved in the SOLIDWORKS model are imported as SOLIDWORKS Visualize Lights on the Scenes tab. All aspects of SOLIDWORKS lights are maintained when translated to SOLIDWORKS Visualize.

All imported lights are **disabled** by default when imported, regardless of whether they were ON in SOLIDWORKS and/or PhotoView 360 when the model was saved. Ambient light sources are never imported from SOLIDWORKS.

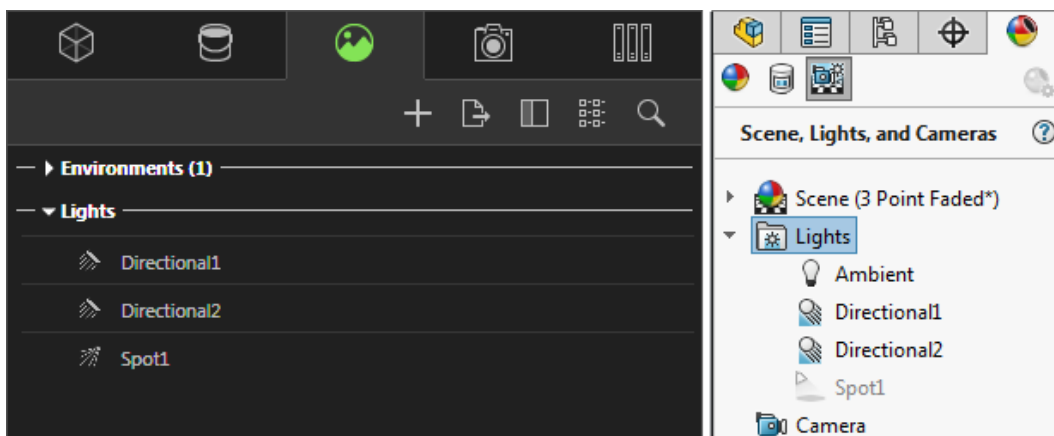

Interactivity Performance Improvements

SOLIDWORKS Visualize 2018 includes three main improvements to the raytracing performance:

- Faster interactivity directly in the Viewport with **Fast** and **Accurate** raytracing modes
- Added new **Fast** raytracing mode switch for even faster **Fast** mode
- Ability to set the default number of passes for **Fast** raytracing mode

Faster Interactivity Directly in the Viewport

Officially included in the 2017 SP2 release, Viewport interactivity performance was significantly improved when interacting with the camera and/or geometry with **Fast** or **Accurate** modes enabled. No setting change is required to see these performance improvements.

Fast Raytracing Mode Switch

SOLIDWORKS Visualize 2018 includes a **Fast** mode toggle switch: **Speed** or **Quality**. You can access this switch from the Main toolbar.

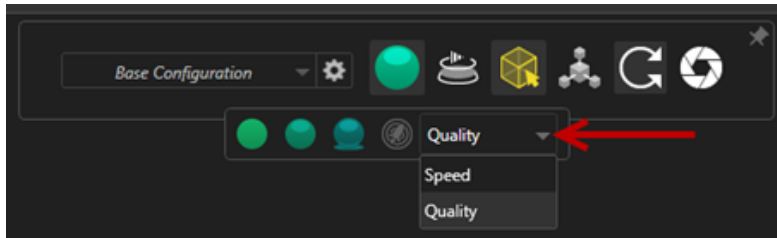

Speed: Recommended for fastest interactivity in the Viewport.

- This new **Fast** render setting completes renders almost two times faster than in previous versions by removing self-shadowing and time-consuming reflections.
- This is ideal for projects without glass, clear plastics, or transparent objects.

Quality: Recommended for final renders.

- This new **Fast** render mode is actually more realistic and advanced than the previous **Fast** render mode. This mode has some of the more photorealistic features found in **Accurate** mode, but with the faster raytracing speeds of **Fast** mode.
- This new **Fast** mode allows for a greater usage of **Fast** raytracing mode throughout more and more projects. Accurate raytracing mode is only required for interior scenes.



For more information, see this [Visualize Forum thread](#).

Set Default Number of Passes for Fast Raytracing Mode

With the **Fast** mode toggle switch between Speed and Quality, you have the option to set the default number of **Render Passes** for the Fast render mode. Click **Tools > Options > 3D Viewport > Fast Rendering Mode**.

Some **Fast** mode renders can still be noisy, so this setting allows you to adjust the default number of **Fast** mode render passes to reduce any visible noise in final **Fast** mode renders.

The accumulation process stops once this number is reached. Small values lead to shorter render times but may produce noisy images. The default number is sufficient for most projects.

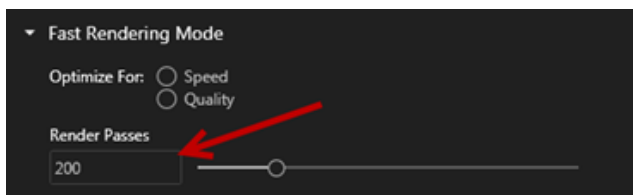

The **Fast** mode setting (**Speed** or **Quality**) and Render Pass count selected in the Viewport are the settings used during an offline render if you select **Fast** mode.

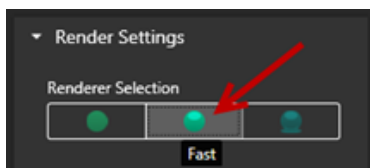

Remove Camera Post-Processing from Backplates

When using a backplate image or background color as the visible background in your scene, you can choose to have the Camera Post Processing Options only impact the model.

Click **Cameras > Filters** . Under **Post-Processing Options**, select **Apply To Geometry Only**. This option results in the post-processing effects only applying to the model, and not a backplate or background color.

If the visible background is the HDR environment image itself, this option has no visible effect.



Apply To Geometry Only selected



Apply To Geometry Only cleared

Stereoscopic and 360° Cameras for Virtual Reality

SOLIDWORKS Visualize Professional provides tools and methods to create three dimensional (3D) and 360° images and videos (animations) that can be used to prepare interactive Virtual Reality (VR) content.

These new VR features are only available in SOLIDWORKS Visualize Professional.

Application Examples

Social Media

You can post 360° images on social media sites such as Facebook® 360 Photos to create interactive, panoramic experiences. You can also export 360° videos that are handled in a similar way, for example Facebook® 360 Videos. While these videos are playing, you can choose your perspective throughout the entire 360°. When played on mobile devices that employ gyroscopes, the motion of the device defines the perspective or viewing direction, giving you the illusion of having a window into the virtual world.

VR Headsets

You can use stereographic and 360° images as input for VR headsets, giving users the impression they are in the virtual scene while allowing them to look in every direction. These stereographic and 360° images can also be exported as videos and uploaded to YouTube® where they appear as VR-360 videos, ready to be streamed and consumed from any VR device.

HDR Environments

When you export 360° images in a high dynamic range format such as `.HDR` or `.EXR`, you can reload the resulting images as HDR Environments into SOLIDWORKS Visualize. You can then set up your own scenes to customize reflections and lighting for subsequent visualization purposes.

360 Lens

In addition to **Perspective** and **Orthographic** camera projections, **360** is now available.

360 is not supported in the Preview render mode.

The **360** lens is a nonlinear type of projection that captures the whole 360° environment around the camera's position into a single wide screen image. The result displays in a **Lat/Long** or **Equirectangular** image that resembles a photo with an extreme fish eye lens.

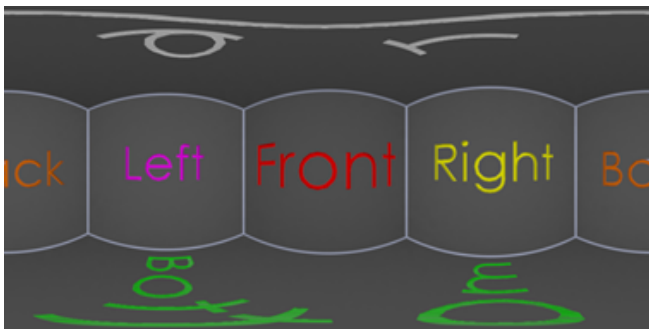

In this example, two images of an interior scene are created from the same camera position using **Perspective** and **360** projections.

**Perspective****360**

Stereoscopy

Stereo rendering computes two images at the same time, one for the left eye and one for the right eye.

To use Stereo rendering:

1. On the Palette, on the Cameras  tab, on the General subtab, for **Type**, select **Perspective** or **360**.
2. On the Stereo subtab, for **Mode**, select **Stereo Two-Up** or **Stereo Anaglyph**.

Perspective and **360** camera projection types support stereo rendering. SOLIDWORKS Visualize provides two modes to display the left and right eye images.

Stereo Two-Up Mode

Stereo Two-Up Mode displays both images at the same time. The left image is on top; the right image is on the bottom.

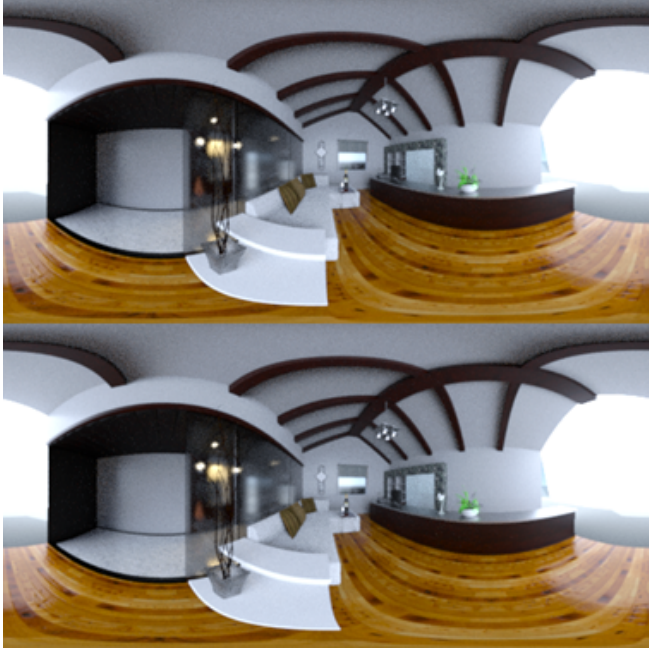

Stereo Anaglyph Mode

Stereo Anaglyph Mode overlays the two images using color filters (chromatically opposite colors red and cyan) to produce 3D images that you can view using inexpensive red/cyan stereo glasses. In addition, it helps to see the stereo parallax effect. In this example, the zero parallax or focal point is set on the wine bottle in the center of the image.

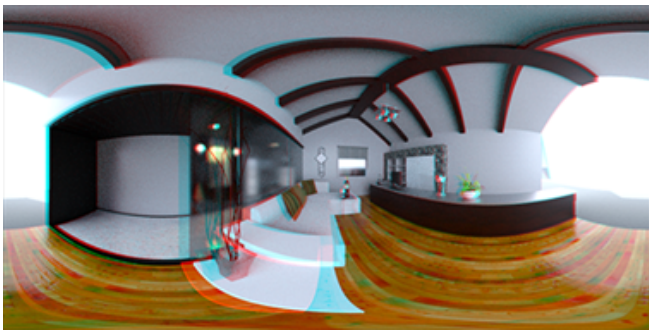

Other Stereo Parameters

You can control the intensity of the stereo effect using the **Eye Separation** and **Focal Distance** parameters. The **Focal Distance** (distance from camera position in viewing direction) defines the zero parallax or point of convergence between the left and right images for a given **Eye Separation**. Click **Pick** and select an object in the 3D viewport using the crosshairs cursor to specify the **Focal Distance**.

Updated User Interface

SOLIDWORKS Visualize 2018 has a restyled user interface with a modern, clean design theme that reflects current industry and market trends. This modernized user interface includes restyled icons that complement the new design theme and increased spacing that helps with touchscreen support.

Use **Tools > Options > User Interface > Interface Options** to switch between **Dark** and **Light** themes.



Dark

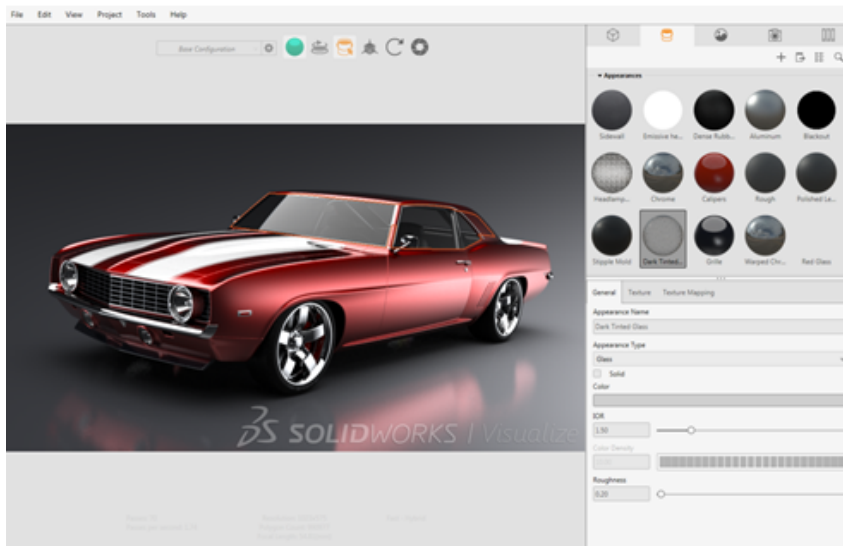

Light

Other Main User Interface Updates

- Palette subtabs simplify lengthy settings.

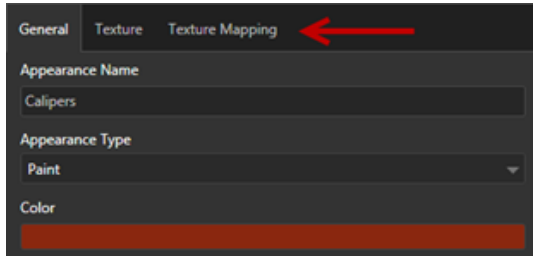

- To toggle the palette layout between vertical and horizontal, click **Change Layout** (Palette toolbar).
- In **Large List** palette views, additional information is available.
- Simplified right-click context menu.

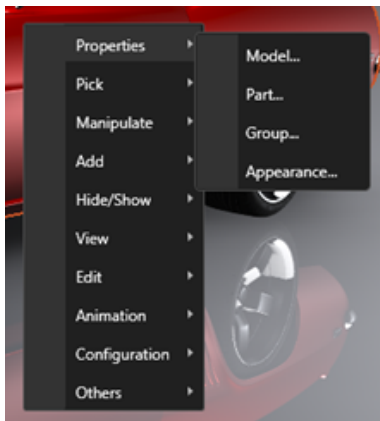

- Reorganized Output tools.

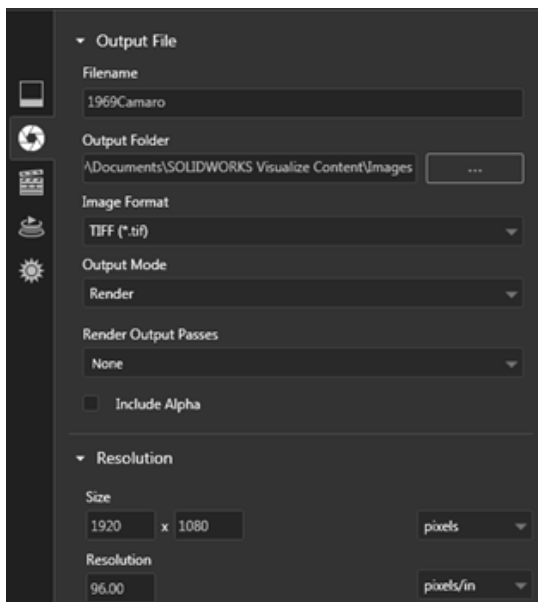

- New Camera Orthographic and Isometric view presets on the Main toolbar that are similar to SOLIDWORKS.

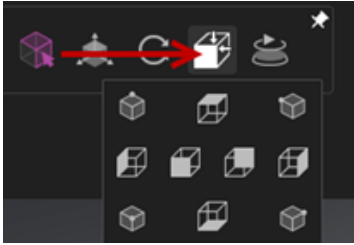

- To toggle the camera between locked and unlocked, press **L**.
- For camera zoom to fit, press **F**.
- You can enable a SOLIDWORKS Visualize watermark, which is overlaid on the lower-right corner of the viewport and final renders. Click **Tools > Options > 3D Viewport > Display Options > Show Watermark**.
- Larger viewport resolutions (up to 4K) are now supported.

32

Weldments

This chapter includes the following topics:

- [Customizing Description for Bounding Box Properties](#)
- [Linking a Cut List Folder to a Cut List Property](#)

Customizing Description for Bounding Box Properties

You can customize the default description settings for new and existing bounding box properties for solid and sheet metal cut list bodies in **Tools > Options > Document Properties > Weldments**.

To customize description settings in bounding box properties:

1. With a document open, click **Options**  (Standard toolbar). On the **Document Properties** tab, select **Weldments**.
2. In the Bounding Box Properties section, to change a description for solid bodies:
 - a) Clear **Use default description**.
 - b) In the description field, overwrite `Plate` and type a new description.
 - c) Click the drop down arrow to change the order of **SW-Thickness**, **SW-Length**, or **SW-Width**. If you select **None** from the list, the element is removed from the text expression.
3. To change a description for sheet metal bodies:
 - a) Clear **Use default description**.
 - b) In the description field, type a new description.
4. Select an option to apply the changes to existing and new bounding boxes, or new bounding boxes only.

Changes to existing bounding box descriptions cannot be reversed.

5. Click **OK**.

Linking a Cut List Folder to a Cut List Property

In the Cut-List Properties dialog box, you can add a custom property that links a cut list folder to its cut list folder name. You can then include this cut-list property in BOMs,

notes, and sheet formats. This property helps to identify members in large multibody weldments.

To link a cut list folder to a cut list property:

1. In the FeatureManager design tree, right-click a **Cut-List-Folder** and click **Properties**.
2. On the **Cut List Summary** tab, click an empty cell under **Property Name** and add a new property.
3. Under **Value/Text Expression**, choose **Cut List Item Name** from the list.

The text in **Value/Text Expression** displays `SW-CutListItemName@@@<Cutlist folder name>@<Part name.Sldprt` and the evaluated value displays the cut list folder name.

www.solidworks.com

Dassault Systèmes SolidWorks Corp.
175 Wyman Street
Waltham, MA 02451
Phone: 1 800 693 9000
Outside the US: +1 781 810 5011
Email: generalinfo@solidworks.com

Europe Headquarters
Phone: +33 4 13 10 80 20
Email: infoeurope@solidworks.com

Japan Headquarters
Phone: +81 3 6270 8700
Email: infojapan@solidworks.com

Asia/Pacific Headquarters
Phone: +65 6511 9188
Email: infoap@solidworks.com

Latin America Headquarters
Phone: +55 11 3186 4150
Email: infoa@solidworks.com

Our **3DEXPERIENCE**® platform powers our brand applications, serving 12 industries, and provides a rich portfolio of industry solution experiences.

Dassault Systèmes, the **3DEXPERIENCE**® Company, provides business and people with virtual universes to imagine sustainable innovations. Its world-leading solutions transform the way products are designed, produced, and supported. Dassault Systèmes' collaborative solutions foster social innovation, expanding possibilities for the virtual world to improve the real world. The group brings value to over 220,000 customers of all sizes in all industries in more than 140 countries. For more information, visit www.3ds.com.



3DEXPERIENCE®

 **DASSAULT SYSTEMES** | The **3DEXPERIENCE**® Company

Americas
Dassault Systèmes
175 Wyman Street
Waltham, Massachusetts
02451-1223
USA

Europe/Middle East/Africa
Dassault Systèmes
10, rue Marcel Dassault
CS 40501
78946 Vélizy-Villacoublay Cedex
France

Asia-Pacific
Dassault Systèmes K.K.
ThinkPark Tower
2-1-1 Osaki, Shinagawa-ku,
Tokyo 141-6020
Japan

©2018 Dassault Systèmes. All rights reserved. **3DEXPERIENCE**®, the Compass icon, the 3D logo, CARTA, SOLIDWORKS, ENOVIA, DELMIA, SIMULIA, GEODIA, EXALEAD, 3D VIA, BIOVIA, NETVIBES, IPWE and 3DEXITE are commercial trademarks or registered trademarks of Dassault Systèmes, a French "société européenne" (Versailles Commercial Register # B.322.306.440), or its subsidiaries in the United States and/or other countries. All other trademarks are owned by their respective owners. Use of any Dassault Systèmes or its subsidiaries trademarks is subject to their express written approval.